

Magnetostrictive level transmitter

High-resolution measurement principle

Models FLM-S, FLM-T, FLM-P

WIKA data sheet LM 20.01



for further approvals
see page 3



Applications

- High-accuracy level detection for almost all liquid media
- Chemical, petrochemical industry, natural gas, offshore, shipbuilding, machine building, power generating equipment, power plants
- Process water and drinking water treatment, food and beverage industry, pharmaceutical industry

Special features

- Process- and procedure-specific solutions possible
- Operating limits:
 - Operating temperature: $T = -90 \dots +450 \text{ °C} [-130 \dots +842 \text{ °F}]$
 - Operating pressure: $P = \text{vacuum to } 100 \text{ bar } [1,450.4 \text{ psi}]$
 - Limit density: $\rho \geq 400 \text{ kg/m}^3 [25.0 \text{ lbs/ft}^3]$
- Resolution $< 0.1 \text{ mm}$
- Wide variety of different electrical connections, process connections and materials
- Explosion-protected versions



Level transmitter with flange connection, model FLM-T

Description

The model FLM-S, FLM-T and FLM-P level transmitters are used for the high-accuracy, continuous level detection of liquids and are based on determining the position of a magnetic float according to the magnetostrictive measurement principle.

Further special features

- Large range of application due to the simple, proven functional principle
- Process connection, guide tube and float from stainless steel 1.4571, 1.4435, 1.4539 or plastic
- For harsh operating conditions, long service life
- Continuous detection of levels, independent of physical and chemical changes of the media such as: Foaming, conductivity, dielectric, pressure, vacuum, temperature, vapours, condensation, bubble formation, boiling effects, density change
- Signal transmission over long distances
- Simple installation and commissioning, onetime calibration only, no recalibration necessary
- Level displayed proportional to volume or height
- Parallel measurement of interface layer and overall level possible via HART® interface

Options

- Customer-specific solutions
- Process connection, guide tube and float from special steel, titanium, Hastelloy (others on request)
- In combination with limit switch, stepless setting of the limit values over the entire measuring range

Illustration of the principle

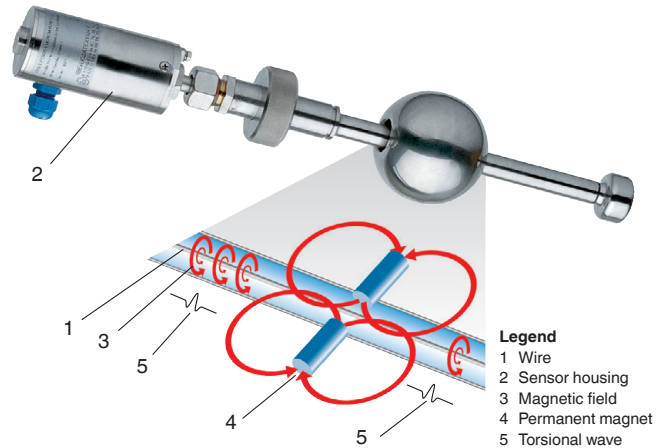

Design and operating principle

- The measuring process is triggered by a current impulse. This current produces a circular magnetic field (3) along a wire (1) made of magnetostrictive material fixed in the guide tube.
- At the point being measured (liquid level) there is a float with permanent magnets (4) acting as a position transducer.
- The superposition of these two magnetic fields triggers a mechanical torsional wave (5) in the wire.
- This is converted into an electrical signal at the end of the wire in the sensor housing by a piezoceramic converter.
- The measured propagation delay enables the origination point of the mechanical wave, and thus the float position, to be determined with high accuracy.











Model overview

Level transmitter	Description	Materials					
		Stainless steel			Titanium 3.7035 (grade 2)	PP	PVDF
		1.4571 (316Ti)	1.4404 (316L)	1.4435 (316L)			
FLM-S (FFG-P)	Standard version	x	x	-	x	-	-
FLM-T (FFG-T)	High-temperature version	x	x	-	x	-	-
FLM-P (FFG-TP)	Plastic version	-	-	-	-	x	x

Temperature range (process)

- Model FLM-S -60 ... +185 °C [-76 ... +365 °F]
- Model FLM-T -90 ... +450 °C [-130 ... +842 °F]
- Model FLM-P -10 ... +100 °C [14 ... 212 °F]

Approvals

Logo	Description	Country
 	EU declaration of conformity <ul style="list-style-type: none"> ■ EMC directive EN 61326 emission (group 1, class B) and immunity (industrial application) ■ RoHS directive ■ ATEX directive (option) Hazardous areas Model FLM-SxI (FFG-P...) - Ex i II 1/2G Ex ia IIC T3 ... T6 Model FLM-TAI (FFG-T...) - Ex i II 1/2G Ex ia IIC T6 ... T4 Ga/Gb II 1D Ex ia IIIC T160 °C Da Model FLM-SxD (FFG-P...) - Ex d II 1/2G Ex d IIB T3 ... T6 Ga/Gb	European Union
 	IECEx (option) Hazardous areas - Ex i II 1/2G Ex ia IIC T6 ... T4 Ga/Gb II 1D Ex ia IIIC T160 °C Da	International
	FM (only model FLM-S) Hazardous areas - XP CI I Div 1 Gp B, C, D, T* - DIP CI II, III Div 1 Gp E, F, G, T*; IP67	USA
	EAC <ul style="list-style-type: none"> ■ EMC directive ■ Hazardous areas 	Eurasian Economic Community
	GOST Metrology, measurement technology	Russia
	KazInMetr Metrology, measurement technology	Kazakhstan
	BelGIM Metrology, measurement technology	Belarus
	UkrSEPRO Metrology, measurement technology	Ukraine
	Uzstandard Metrology, measurement technology	Uzbekistan

Manufacturer's information and certificates

Logo	Description
	SIL Functional safety <ul style="list-style-type: none"> ■ SIL 2 for model FLM-T (FFG-T) ■ SIL 2, SIL 3 for model FLM-S (FFG-P)

Approvals and certificates, see website

Standard version, explosion-protected version, model FLM-S

II 1/2G Ex ia IIC T3 ... T6 or II 1/2G Ex d IIB T3 ... T6 Ga/Gb

Process connection, guide tube and float from stainless steel 1.4571

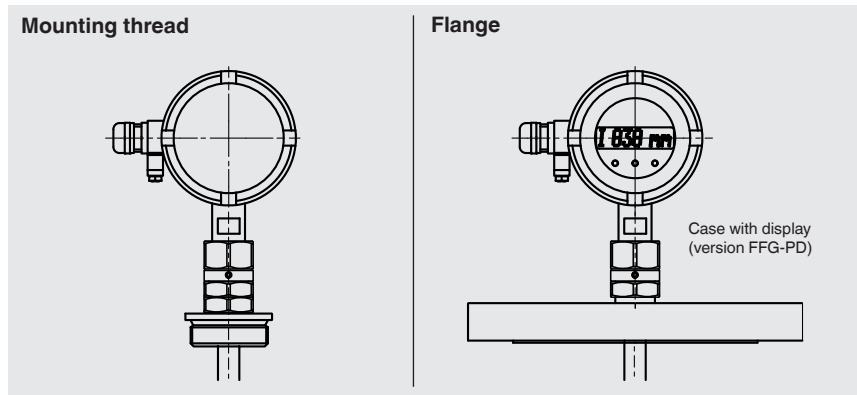
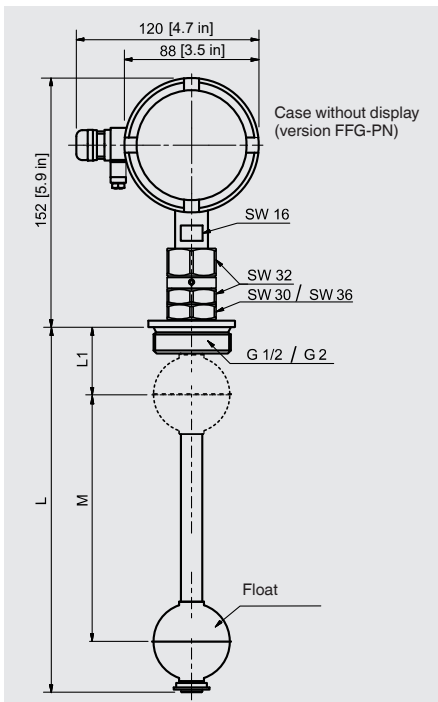

	Mounting thread	Flange
Electrical connection	Sensor housing, material stainless steel 1.4404 (316L)	
Display	<ul style="list-style-type: none"> ■ Version FLM-SA (FFG-PN) without display ■ Version FLM-SB (FFG-PD) with window and display ■ LCD matrix (only version FFG-PD) 	
Process connection	Mounting thread downwards <ul style="list-style-type: none"> ■ G 1/2 ... G 2" ■ 1/2 NPT ... 2 NPT 	Mounting flange <ul style="list-style-type: none"> ■ DIN DN 50 ... DN 200, PN 6 ... PN 100 ■ ANSI 2" ... 8", class 150 ... 600
Max. guide tube length L		
Guide tube Ø 14 mm [0.6 in]	3,500 mm [137.8 in]	
Guide tube Ø 18 mm [0.7 in]	5,800 mm [228.3 in]	
Float	Material: Stainless steel 1.4571 (option: Titanium) Float diameter from 44 ... 120 mm [1.7 ... 4.7 in] Float selection depending on guide tube Ø and process conditions (→ see page 9 / 10) Attention: With Ex approval no floats from titanium may be used.	
Max. operating pressure	40 bar [580.2 psi] (100 bar [1,450.4 psi] with float from titanium) → See table on page 9 / 10	
Temperature range		
Medium (standard)	-60 ... +185 °C [-76 ... +365 °F]	
Ambient temperature		
Version without display	-40 ... +85 °C [-40 ... +185 °F]	
Version with display	-20 ... +70 °C [-4 ... +158 °F]	
	Ex i version	T3/T4/T5: -20 ... +70 °C [-4 ... +158 °F] T6: -20 ... +60 °C [-4 ... +140 °F]
	Ex d version	T3/T4/T5: -20 ... +70 °C [-4 ... +158 °F] T6: -20 ... +60 °C [-4 ... +140 °F]
Output signal	4 ... 20 mA, HART® rev. 7	
Supply voltage	DC 15 ... 30 V	

	Mounting thread	Flange
Measurement accuracy	< ±0.5 mm	
Resolution	< 0.1 mm	
Temperature coefficient		
4 ... 20 mA output signal	0.2 % F.S. / 10 K	
HART® output signal	0.05 % F.S. / 10 K	
Load	max. 900 Ω at 30 V	
Mounting position	Vertical ±30°	
Ingress protection	IP66/IP68 per IEC/EN 60529	

High-temperature version, model FLM-T

Process connection, guide tube and float from stainless steel 1.4571

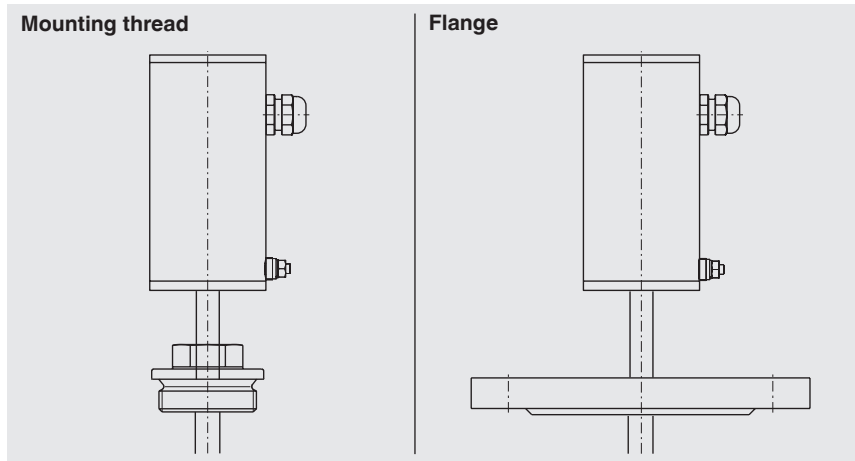
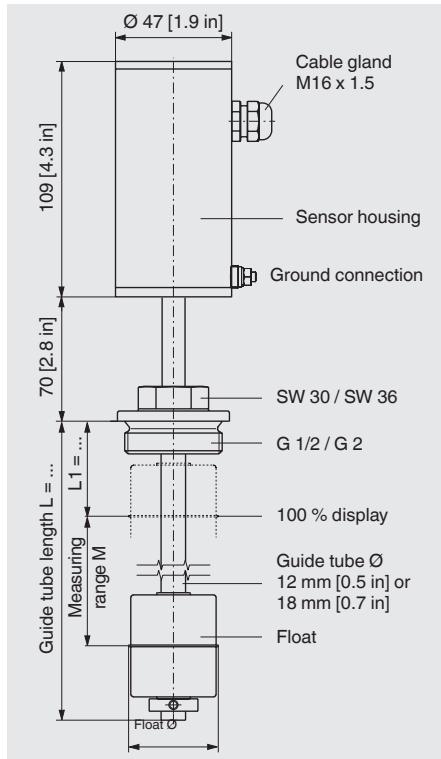

	Mounting thread	Flange
Electrical connection	Sensor housing, material stainless steel 1.4301	
Process connection	Mounting thread downwards ■ G 1/2 ... G 2" ■ 1/2 NPT ... 2 NPT	Mounting flange ■ DIN DN 50 ... DN 200, PN 6 ... PN 100 ■ ANSI 2" ... 8", class 150 ... 600
Max. guide tube length L		
Guide tube $\varnothing 12$ mm [0.5 in]	3,000 mm [118.1 in]	
Guide tube $\varnothing 18$ mm [0.7 in]	6,000 mm [236.2 in]	
Float	Material: Stainless steel 1.4571 (option: Titanium) Float diameter from 44 ... 120 mm [1.7 ... 4.7 in] Float selection depending on guide tube \varnothing and process conditions (→ see page 9 / 10)	
Max. operating pressure	40 bar [580.2 psi] (100 bar [1,450.4 psi] with float from titanium) → see table on page 9 and 10	
Temperature range		
Medium (standard)		
High-temperature version	-45 ... +450 °C [-49 ... +842 °F]	
Low-temperature version	-90 ... +125 °C [-130 ... +257 °F]	
Ambient temperature	-40 ... +85 °C [-40 ... +185 °F]	
Output signal	4 ... 20 mA, HART® rev. 6	
Supply voltage	DC 10 ... 30 V	
Measurement accuracy	< ±0.5 mm	
Resolution	< 0.1 mm	
Load	max. 900 Ω at 30 V	
Mounting position	Vertical ±30°	
Ingress protection	IP68 per IEC/EN 60529	

High-temperature version, explosion-protected version, model FLM-TAI

II 1/2G Ex ia IIC T6 ... T2 Ga/Gb, II 1/2G Ex ia IIC T6 ... T4 Ga/Gb or II 1D Ex ia IIC T160 °C Da

Process connection, guide tube and float from stainless steel 1.4571

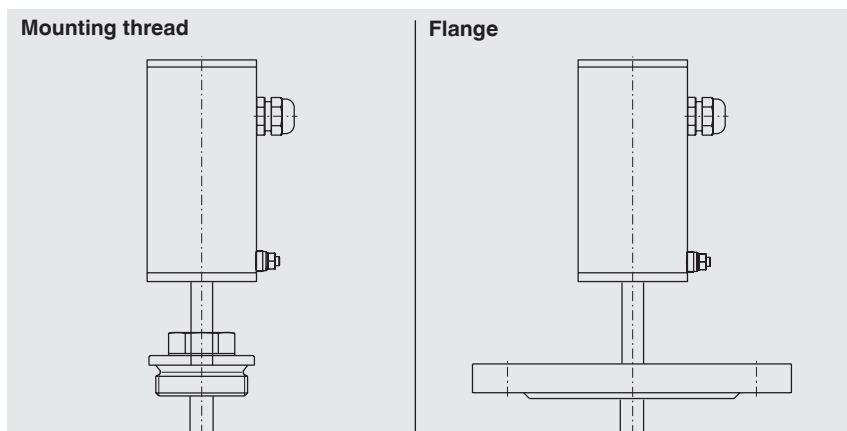
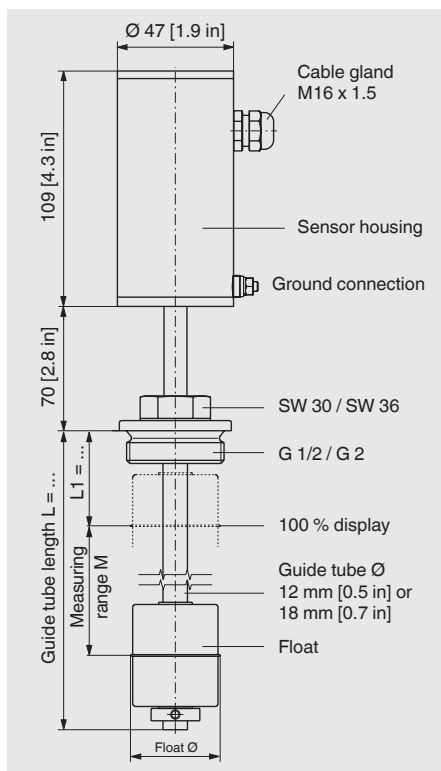

	Mounting thread	Flange
Electrical connection	Sensor housing, material stainless steel 1.4301	
Process connection	Mounting thread downwards <ul style="list-style-type: none"> ■ G 1/2 ... G 2" ■ 1/2 NPT ... 2 NPT 	Mounting flange <ul style="list-style-type: none"> ■ DIN DN 50 ... DN 200, PN 6 ... PN 100 ■ ANSI 2" ... 8", class 150 ... 600
Max. guide tube length L		
Guide tube Ø 12 mm [0.5 in]	3,000 mm [118.1 in]	
Float	Material: Stainless steel 1.4571 (option: Titanium) Float diameter from 44 ... 120 mm [1.7 ... 4.7 in] Float selection depending on guide tube Ø and process conditions (→ see page 9 / 10)	
Max. operating pressure	40 bar [580.2 psi] (100 bar [1,450.4 psi] with float from titanium) → see table on page 9 and 10	
Temperature range		
Category 1G (sensor completely in zone 0)	Max. process temperature	-20 ... +60 °C [-4 ... +140 °F] (T4 ... T1)
	Max. ambient temperature	-20 ... +60 °C [-4 ... +140 °F] (T4 ... T1)
Category 1/2G (sensor head installed in zone 1, sensor tube installed in zone 0)	Max. process temperature	-20 ... +60 °C [-4 ... +140 °F] (T4 ... T1)
	Max. ambient temperature	-40 ... +85 °C [-40 ... +185 °F] (T4 ... T1)
Category 2G (sensor completely in zone 1)	Max. process temperature	-40 ... +450 °C [-40 ... +842 °F] (T1)
	Max. ambient temperature	-40 ... +85 °C [-40 ... +185 °F] (T4 ... T1)
Output signal	4 ... 20 mA, HART® rev. 6	
Supply voltage	DC 10 ... 30 V	
Measurement accuracy	< ±0.5 mm	
Resolution	< 0.1 mm	
Load	max. 900 Ω at 30 V	
Electrical input data	U _i ≤ 30 V / I _i ≤ 100 mA, 200 mA / P _i ≤ 1 W / C _i ≤ 10 nF / L _i ≤ 20 μH	
Mounting position	Vertical ±30°	
Ingress protection	IP68 per IEC/EN 60529	

Plastic version, model FLM-P

Process connection, guide tube and float from PVC, polypropylene or PVDF

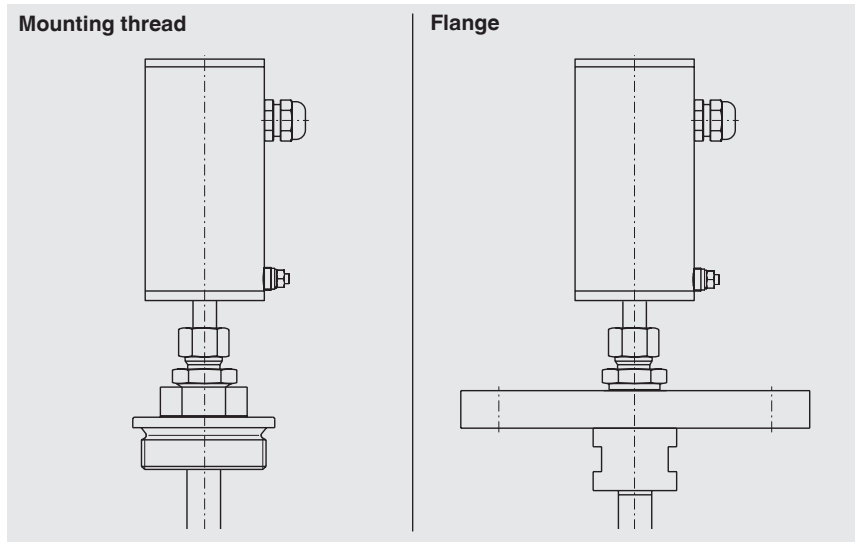
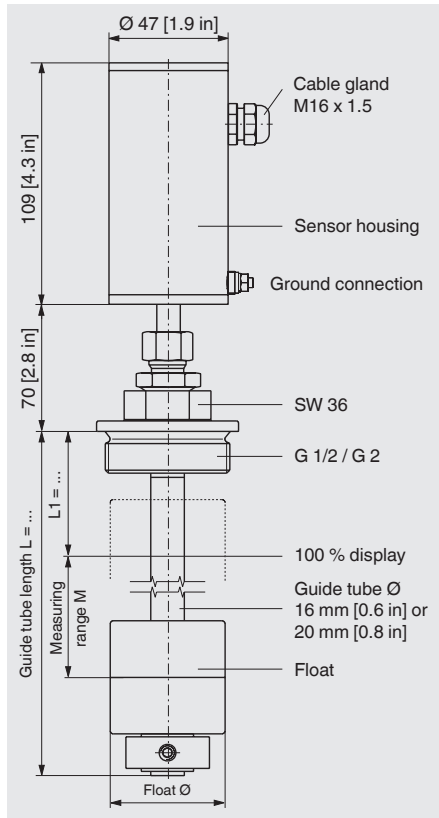

	Mounting thread	Flange
Electrical connection	Sensor housing, material stainless steel 1.4305	
Process connection	Mounting thread downwards ■ G 1/2 ... G 2" ■ 1/2 NPT ... 2 NPT	Mounting flange ■ DIN DN 50 ... DN 200, PN 6 ... PN 100 ■ ANSI 2" ... 8", class 150 ... 600
Max. guide tube length L		
Guide tube $\varnothing 16$ mm [0.6 in]	3,000 mm [118.1 in]	
Guide tube $\varnothing 20$ mm [0.8 in]	5,000 mm [196.9 in]	
Float	Material: Polypropylene, PVDF or PVC Float diameter of 55 mm [2.2 in] or 80 mm [3.1 in] Float selection depending on guide tube \varnothing and process conditions (\rightarrow see page 9 / 10)	
Max. operating pressure	3 bar [43.5 psi]	
Temperature range		
Medium		
Polypropylene	-10 ... +80 °C [14 ... 176 °F]	
PVDF	-10 ... +100 °C [14 ... 212 °F]	
Ambient temperature	-40 ... +85 °C [-40 ... +185 °F]	
Output signal	4 ... 20 mA, HART® rev. 6	
Supply voltage	DC 10 ... 30 V	
Measurement accuracy	< ± 0.5 mm	
Resolution	< 0.1 mm	
Load	max. 900 Ω at 30 V	
Mounting position	Vertical $\pm 30^\circ$	
Ingress protection	IP68 per IEC/EN 60529	

Spherical float

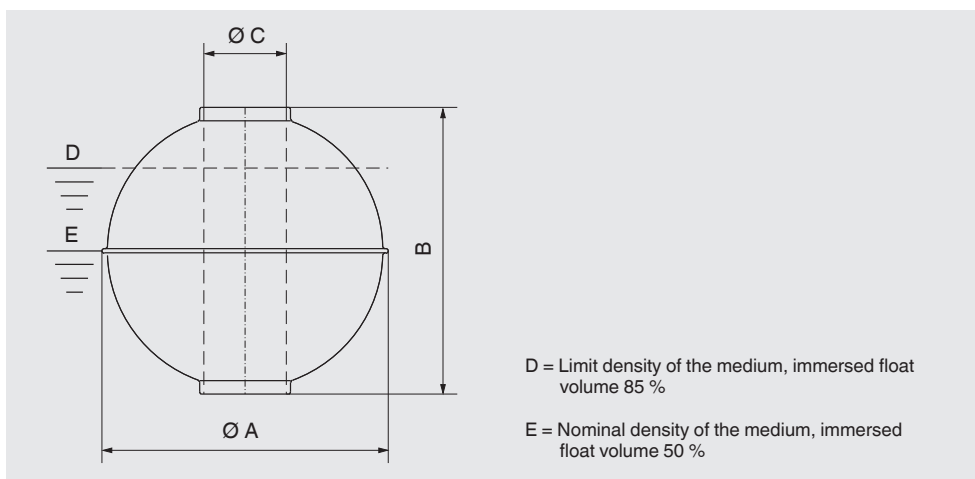

Material	Version	Suits guide tube Ø in mm	Ø A in mm	B in mm	Ø C in mm	Max. operating pressure in bar	Max. operating temp. in °C	Limit density 85 % in kg/m ³
Stainless steel 1.4571 (316Ti)	V52A	14	52	52	15	40	250	720
	V62A	14	62	61	15	32	250	597
	V83A	14	83	81	15	25	250	430
	V80A	18	80	76	23	25	250	660
	V98A	18	98	96	23	25	250	597
	V105A	18	105	103	23	25	250	533
	V120A	18	120	117	23	25	250	389
	V120/38A	18	120	116	38	25	250	537
Titanium 3.7035 (grade 2)	T52A	14	52	52	15	25	250	570
	T62A	14	62	62	15	25	250	505
	T83A	14	83	81	15	25	250	350
	T80A	18	80	76	23	25	250	665
	T98A	18	98	96	23	25	250	495
	T105A	18	105	103	23	25	250	369
	T120A	18	120	117	23	25	250	329

Special floats for higher temperature and pressure ranges are available on request.

Note: The optimum float will be selected after a feasibility test carried out by WIKA.

Cylindrical float

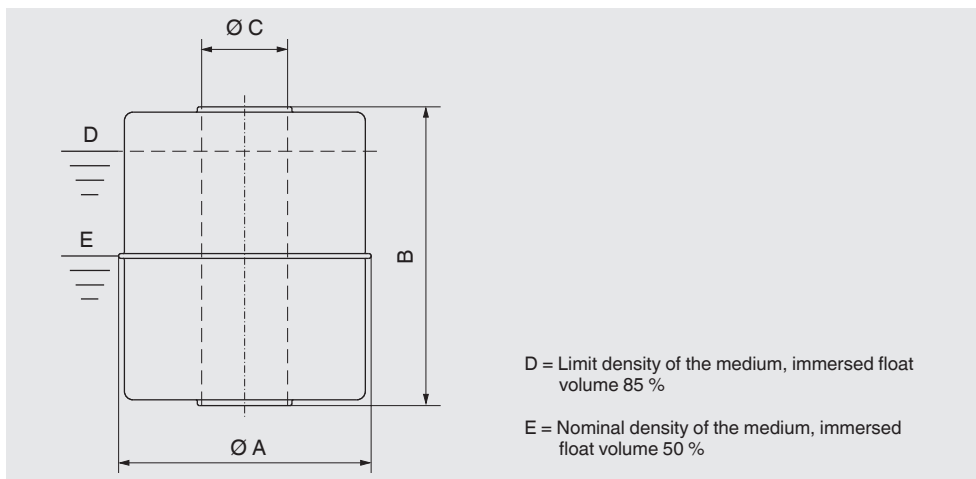

Material	Version	Suits guide tube Ø in mm	Ø A in mm	B in mm	Ø C in mm	Max. operating pressure in bar	Max. operating temp. in °C	Limit density 85 % in kg/m ³
Stainless steel 1.4571 (316Ti)	V44A	14	44	52	15	16	250	818
	V44A	14	44	52	15	25	200	800
Titanium 3.7035 (grade 2)	T44A	14	44	52	15	16	250	550
PVC	P55A	16	55	54	22	3	60	798
	P80A	20	80	79	25	3	60	573
Polypropylene	PP55A	16	55	54	22	3	80	595
	PP80A	20	80	79	25	3	80	431
PVDF	PF55A	16	55	69	22	3	100	821
	PF80A	20	80	79	25	3	100	681

Special floats for higher temperature and pressure ranges are available on request.

Note: The optimum float will be selected after a feasibility test carried out by WIKA.

Accessories

Description	Order number
 <p>Display module, model DIH50 5-digit display, 20-segment bar graph, without separate power supply, with additional HART® functionality. Automatic adjustment of measuring range and span. Secondary-master functionality: Setting the measuring range and unit of the connected transmitter using HART® standard commands possible. Optional: Explosion protection per ATEX</p>	On request

Ordering information

Model / Version / Electrical connection / Process connection / Guide tube diameter / Guide tube length (insertion length) L / 100 % mark L1 / Measuring range M (span 0 ... 100 %) / Process specifications (operating temperature and pressure, limit density) / Options

© 03/2010 WIKA Alexander Wiegand SE & Co. KG, all rights reserved.
 The specifications given in this document represent the state of engineering at the time of publishing.
 We reserve the right to make modifications to the specifications and materials.

Your WIKA Sales Partner



ICS Schneider Messtechnik GmbH
 Briesestrasse 59
 D-16562 Hohen Neuendorf / OT Bergfelde
 Tel.: +49 3303 5040-66
 Fax: +49 3303 5040-68
 E-Mail: info@ics-schneider.de



WIKAL Alexander Wiegand SE & Co. KG
 Alexander-Wiegand-Straße 30
 63911 Klingenberg/Germany
 Tel. +49 9372 132-0
 Fax +49 9372 132-406
info@wika.de
www.wika.de