

Load pin

Heavy Duty version with thin film technology from 10 kN [2,248 lbf] Models F5308 standard, F53C8 Atex, F53S8 safety version

WIKA data sheet FO 51.43



Applications

- Crane systems, hoists, offshore, mobile working machines
- Industrial weighing technology
- Machine building and plant construction, manufacturing automation
- Theatre and stage construction
- Chemistry and petrochemistry

Special features

- Measuring ranges from 0 ... 10 kN [from 0 ... 2,248 lbf]
- Stainless steel version (corrosion-resistant)
- Integrated amplifier
- High long-term stability, high shock and vibration resistance
- Good reproducibility, simple installation



Load pin, models F5308 (fig. below), F53S8 (fig. above)

Description

Load pins are suitable for static and dynamic measuring tasks as a replacement for non-measuring pins. They are used to determine the tension and/or compression forces under harsh operating conditions.

Such load pins are very often used in hoists and crane systems, e.g. in construction cranes or in harbour and offshore cranes. Appropriate technical and regional approvals are available as an option.

The load pins are made of high-strength, corrosion-resistant stainless steel 1.4542, whose properties are outstandingly suitable for the application areas.

Besides the standard active current and voltage outputs (4 ... 20 mA, 0 ... 10 V) also digital outputs (CANopen®) are available. Redundant output signals are possible.

The load pins can be integrated into a certified WIKA overload protection with model ELMS1 (DIN EN ISO 13849-1 with PL d/Cat. 3).

Specifications in accordance with VDI/VDE/DKD 2638

Model	F5308	F53S8
Rated force F_{nom} kN [lbf]	From 10 [2,248]	
Relative linearity error $d_{lin}^{1)}$	$\pm 1 \% F_{nom} / \pm 1.5 \% F_{nom}$	
Relative repeatability error in unchanged mounting position b_{rg}	$\pm 0.2 \% F_{nom}$	
Temperature effect on		
characteristic value TK_c	0.2 % $F_{nom} / 10$ K	
zero signal TK_0	0.2 % $F_{nom} / 10$ K	
Force limit F_L	200 % F_{nom}	
Breaking force F_B	500 % F_{nom}	
Shear force influence d_Q (Signal with 100 % F_{nom} under 90°)	$\pm 5 \% F_{nom}$	
Rated displacement (typ.) s_{nom}	< 0.1 mm [< 0.004 in]	
Material of measuring device	Stainless steel corrosion-resistant 1.4542, ultrasonically tested 3.1 material (optional 3.2)	
Rated temperature $B_{T, nom}$	<ul style="list-style-type: none"> ■ -20 ... +80 °C [-4 ... +176 °F] ■ -40 ... +120 °C [-40 ... +248 °F] 	-20 ... +80 °C [-4 ... +176 °F]
Operating temperature $B_{T, G}$	<ul style="list-style-type: none"> ■ -30 ... +80 °C [-22 ... +176 °F] ■ -40 ... +80 °C [-22 ... +176 °F] 	-30 ... +80 °C [-22 ... +176 °F]
Storage temperature $B_{T, S}$	-40 ... +85 °C [-40 ... +185 °F]	
Electrical connection	<ul style="list-style-type: none"> ■ Circular connector M12 x 1, 4-pin or 5-pin ■ CANopen® circular connector M12 x 1, 5-pin ■ MIL connector 	<ul style="list-style-type: none"> ■ 2-circular connector M12 x 1, 4-pin ■ MIL connector
Output signal (rated output) C_{nom}	<ul style="list-style-type: none"> ■ 4 ... 20 mA, 2-wire, ■ 4 ... 20 mA, 3-wire ■ 2 x 4 ... 20 mA, redundant ■ DC 0 ... 10 V, 3-wire ■ 2 x DC 0 ... 10 V redundant ■ CANopen® <p>Protocol in accordance with CiA 301, device profile 404, communication services LSS (CiA 305), configuration of the instrument address and baud rate Sync/Async, Node/Lifeguarding, heartbeat; zero and span ± 10 % adjustable via entries in the object directory ²⁾</p>	<ul style="list-style-type: none"> ■ Redundant, opposing ■ 4 ... 20 mA, 3-wire/20 ... 4 mA, 3-wire versions in accordance with requirements, for functional safety, per 2006/42/EC Machinery Directive
Current consumption	<ul style="list-style-type: none"> ■ Current output 4 ... 20 mA, 2-wire: signal current ■ Current output 4 ... 20 mA, 3-wire: < 8 mA ■ Voltage output: < 8 mA ■ CANopen®: < 1 W 	■ < 8 mA per channel
Supply voltage U_B	<ul style="list-style-type: none"> ■ DC 9 ... 36 V for current output ■ DC 13 ... 36 V for voltage output ■ DC 9 ... 36 V for CANopen® 	■ DC 10 ... 30 V
Burden	<ul style="list-style-type: none"> ■ $\leq (U_B - 10 \text{ V}) / 0.024 \text{ A}$ for current output ■ $> 10 \text{ k}\Omega$ for voltage output 	<ul style="list-style-type: none"> ■ $\leq (U_B - 10 \text{ V}) / 0.020 \text{ A}$ (channel 1) ■ $\leq (U_B - 7 \text{ V}) / 0.020 \text{ A}$ (channel 2)
Response time	$\leq 2 \text{ ms}$ (within 10 ... 90 % F_{nom}) ³⁾	
Protection (per EN/IEC 60529)		
Unplugged condition	IP66, IP67	IP67
Plugged condition	IP68, IP69, IP69K	
Electrical protection	Reverse polarity protection, overvoltage and short-circuit resistance	
Vibration resistance	20 g, 100 h, 50...150 Hz (in accordance with DIN EN 60068-2-6)	
Shock resistance	DIN EN 55011	
Immunity	In accordance with DIN EN 61326-1/DIN EN 61326-2-3 (optional EMC-strengthened versions)	
Intended use	For indoor and outdoor use, at altitudes of to 2,500 m above sea level	
Options	Certificates, strength verifications, 3D/CAD files (STEP, IGES) on request	

1) Relative linearity error in accordance with VDI/VDE/DKD 2638 chap. 3.2.6.

2) Protocol in accordance with CiA DS-301 V.402. Device profile DS-404 V.1.2

3) Other response times are available on request.

CANopen® and CiA® are registered community trade marks of CAN in Automation e.V.

Specifications in accordance with VDI/VDE/DKD 2638

Model	F53C8 ATEX/IECEX EX ib 1)	F53C8 ATEX/IECEX Ex d	F5308 signal jump
Rated force F_{nom} kN [lbf]	From 10 [2,248]		
Relative linearity error d_{lin} 2)	$\pm 1\% F_{nom} / \pm 1.5\% F_{nom}$		
Relative repeatability error in unchanged mounting position b_{rg}	$\pm 0.2\% F_{nom}$		
Temperature effect on			
characteristic value TK_c	0.2 % $F_{nom}/10$ K		
zero signal TK_0	0.2 % $F_{nom}/10$ K		
Force limit F_L	200 % F_{nom}		
Breaking force F_B	500 % F_{nom}		
Shear force influence d_Q (Signal with 100% F_{nom} under 90°) 3)	$\pm 5\% F_{nom}$		
Rated displacement (typ.) s_{nom}	< 0.1 mm [< 0.004 in]		
Material of measuring device	Stainless steel corrosion-resistant 1.4542, ultrasonically tested 3.1 material (optional 3.2)		
Rated temperature $B_{T, nom}$	-20 ... +80 °C [-4 ... +176 °F]		
Operating temperature $B_{T, G}$	Ex II 2G Ex ib IIC T4 Gb -25 °C < Tamb < +85 °C Ex II 2G Ex ib IIC T3 Gb -25 °C < Tamb < +100 °C Ex I M2 Ex ib I Mb -25 °C < Tamb < +85 °C Ex II 2G Ex ib IIC T4 Gb -40 °C < Tamb < +85 °C	Ex II 2G Ex d IIC T4 Gb -40 °C < Tamb < +85 °C	-30 ... +80 °C [-22 ... +176 °F]
Storage temperature $B_{T, S}$	-40 ... +85 °C [-40 ... +185 °F]		
Electrical connection	<ul style="list-style-type: none"> ■ Circular connector M 12x1, 4-pin ■ MIL connector ■ Cable gland 	<ul style="list-style-type: none"> ■ Cable gland (cables which approved for ATEX/IECEX Ex d) 	<ul style="list-style-type: none"> ■ Circular connector M 12x1, 4-pin ■ Cable gland
Output signal (rated output) C_{nom}	<ul style="list-style-type: none"> ■ 4 ... 20 mA, 2-wire 	<ul style="list-style-type: none"> ■ 4 ... 20 mA, 2-wire ■ 4 ... 20 mA, 3-wire 	<ul style="list-style-type: none"> ■ 4 ... 16 mA, 2-wire 4) ■ DC 2 ... 8 V, 3-wire 4)
Current consumption	<ul style="list-style-type: none"> ■ Current output 4 ... 20 mA, 2-wire: signal current 	<ul style="list-style-type: none"> ■ Current output 4 ... 20 mA, 2-wire: signal current, ■ Current output 4 ... 20 mA, 3-wire: < 8 mA 	<ul style="list-style-type: none"> ■ Current output 4 ... 20 mA, 2-wire: signal current, ■ Current output 4 ... 20 mA, 3-wire: < 8 mA, ■ Voltage output: < 8 mA
Supply voltage U_B	<ul style="list-style-type: none"> ■ DC 10 ... 30 V for current output 		<ul style="list-style-type: none"> ■ DC 9 ... 36 V for current output ■ DC 13 ... 36 V for voltage output
Burden	<ul style="list-style-type: none"> ■ < $(U_B - 10 V)/0,024$ A for current output ■ > 10 kΩ for voltage output 		
Response time	≤ 2 ms (within 10 ... 90 % F_{nom}) 5)		
Ingress protection (per EN/IEC 60529)	IP67		
Electrical protection	Reverse polarity protection, overvoltage and short-circuit resistance		
Vibration resistance	20 g, 100 h, 50...150 Hz (in accordance with DIN EN 60068-2-6)		
Shock resistance	DIN EN 55011		
Immunity	In accordance with DIN EN 61326-1/DIN EN 61326-2-3 (optional EMC-strengthened versions)		
Options	Certificates, strength verifications, 3D/CAD files (STEP, IGES)		
Certificates (optional)	ATEX: acc. to EN 60079-0:2012 and EN 60079-11:2012 (Ex ib) IECEX: acc. to IEC 60079-0:2011 (Ed.6) and IEC 60079-11:2011 (Ed. 6) (Ex ib) UL: acc. to UL 61010-1 and CSA C22.2 NO. 61010-1 DNV, standard: DNV-ST-0377 DNV, standard: DNV-ST-0378		

1) The load pins with ignition protection type "ib" must only be supplied using galvanically-isolated power supplies. Suitable supply isolators are also optionally available, eg. item number: 14255084.



2) Relative linearity error in accordance with VDI/VDE/DKD 2638 chap. 3.2.6.

3) This value can be reached when 100 % F_{nom} act. 90° rotated to the axis.





4) Other signal jumps are available on request.

5) Other response times are available on request.

Approvals

Logo	Description	Region
	EU declaration of conformity EMC directive	European Union
	UKCA EMC directive	United Kingdom

Optional approvals

Logo	Description	Region
	ATEX directive (option) Hazardous areas Ex ib Ex II 2G Ex ib IIC T4 Gb $-25\text{ °C} < T_{\text{amb}} < +85\text{ °C}$ Ex II 2G Ex ib IIC T3 Gb $-25\text{ °C} < T_{\text{amb}} < +100\text{ °C}$ Ex I M2 Ex ib I Mb ¹⁾ $-25\text{ °C} < T_{\text{amb}} < +85\text{ °C}$ Ex II 2G Ex ib IIC T4 Gb $-40\text{ °C} < T_{\text{amb}} < +85\text{ °C}$	European Union
	IECEx (Option) Hazardous areas Ex ib Ex ib IIC T4/T3 Gb $-25\text{ °C} < T_{\text{amb}} < +85\text{ °C}$ Ex ib IIC T4 Gb $-25\text{ °C} < T_{\text{amb}} < +100\text{ °C}$ Ex ib I Mb ¹⁾ $-25\text{ °C} < T_{\text{amb}} < +85\text{ °C}$ Ex ib IIC T4 Gb $-40\text{ °C} < T_{\text{amb}} < +85\text{ °C}$	International
	UL Component approval	USA and Canada
	EAC	Eurasian Economic Community
	DNV (Option) ■ Ships, shipbuilding (e.g. offshore)	International

1) Only available with cable connection.

Mounting situation of the load pin

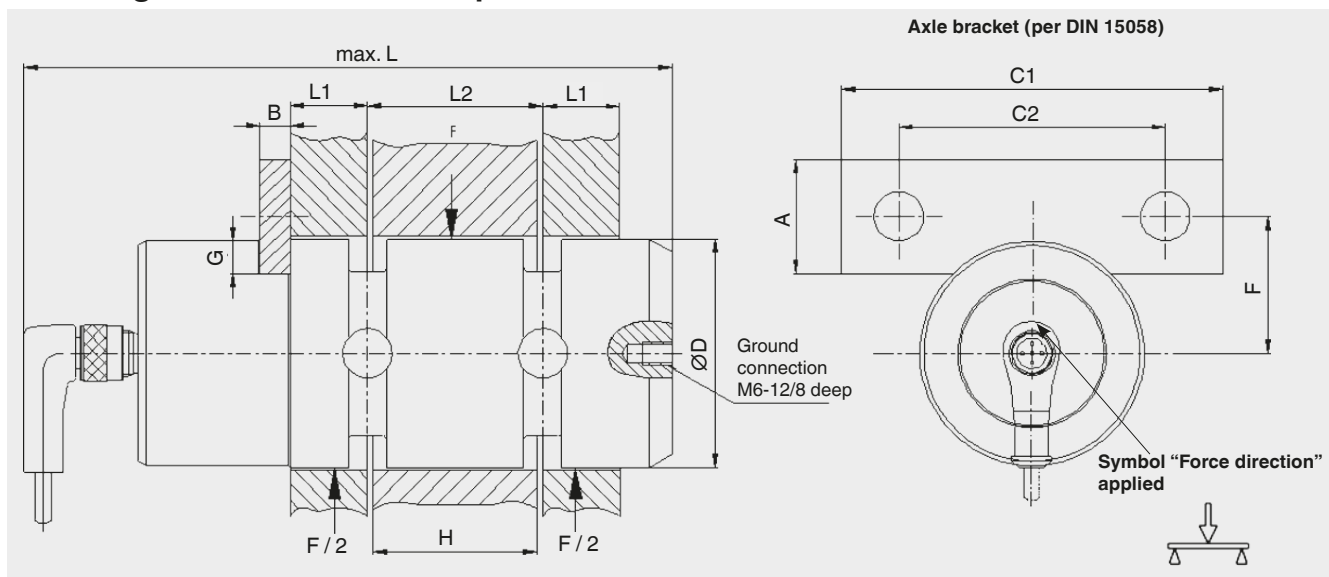

Dimensions: The customer-specific load pin drawing for the specific article number applies above all.
For the F5308, F53C8, F53S8 series, there are no standard dimensions.

Pin assignment of analogue output

4 ... 20 mA output, 2-wire

Circular connector M12 x 1, 5-pin

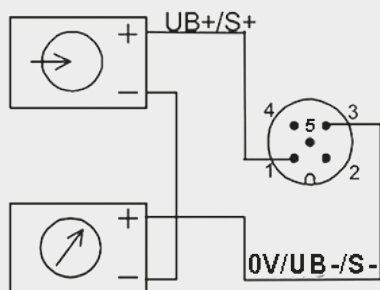

0 ... 10 V output, 3-wire

Circular connector M12 x 1, 5-pin

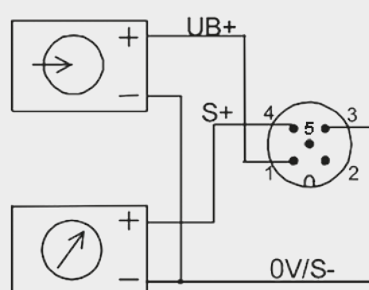

Circular connector M12 x 1, 5-pin

	4 ... 20 mA, 2-wire	4 ... 20 mA, 3-wire	0 ... 10 V, 3-wire
Supply UB+	1	1	1
Supply 0V/UB-	3	3	3
Signal S+	1	4	4
Signal S ₋	3	3	3
Shield	Case	Case	Case

Cable assignment in combination with the circular connector M12 x 1, 5-pin

Cable colour	2-wire	3-wire
Brown	UB+/S+	UB+
White	-	-
Blue	0V/S-	0V/S-
Black	-	S+

Only when using the standard cable,
e.g. item number: 14259454 - Pre-assembled cable, data sheet: DS_AC50.08

Pin assignment of analogue output for ATEX/IECEx

Circular connector M12 x 1, 4-pin

	ATEX/IECEx Ex ib 4 ... 20 mA, 2-wire
Supply UB+	1
Supply 0V/UB-	3
Signal S+	1
Signal S-	3
Shield	Case

Cable output

Cable colour	ATEX/IECEx Ex d 4 ... 20mA, 2-wire	ATEX/IECEx Ex d 4 ... 20mA, 3-wire
Brown	UB+/S+	UB+
White	-	-
Blue	0V/S-	0V/S-
Black	-	S+

Pin assignment of analogue output with signal jump

Circular connector M12 x 1, 4-pin

	4 ... 20 mA, 2-wire	4 ... 20 mA, 3-wire	0 ... 10 V, 3-wire
Supply UB+	1	1	1
Supply 0V/UB-	3	3	3
Relay UR+	2	2	2
Relay UR-	4	3	3
Signal S+	1	4	4
Signal S-	3	3	3
Shield	Case	Case	Case

Cable assignment in combination with the circular connector M12 x 1, 4-pin

Cable colour	2-wire	3-wire
Brown	UB+/S+	UB+
White	UR+	UR+
Blue	0V/S-	0V/S-/UR-
Black	UR-	S+

Only when using the standard cable,
e.g. item number: 14259454 - Pre-assembled cable, data sheet: DS_AC50.08

Pin assignment of analogue output, redundant

Circular connector M12 x 1, 5-pin		Circular connector M12 x 1, 5-pin			Cable assignment in combination with circular connector M12 x 1, 5-pin		
	4 ... 20 mA, 2-wire		4 ... 20 mA, 3-wire	0 ... 10 V, 3-wire	Cable colour	2-wire	3-wire
UB1+/S1+	1	Supply UB+	1	1	Brown	UB1+/S1+	UB+
UB2+/S2+	2	Supply 0V/S-	3	3	White	UB2+/S2+	S1+
UB1-/S1-	3	Signal S1+	4	4	Blue	UB1-/S1-	0V/S-
UB2-/S2-	4	Signal S2+	2	2	Black	UB2-/S2-	S2+
Shield ⊕	Case	Shield ⊕	Case	Case			

Only when using standard cable, e.g. 14259454

Pin assignment of analogue output redundant, opposing

Circular connector M12 x 1, 4-pin		
	4 ... 20 mA, 3-wire / 20 ... 4 mA, 3-wire (redundant)	
	Connector channel 1	Connector channel 2
Supply UB+	1	1
Supply 0V/UB-	3	3
Signal S+	4	4
Shield ⊕	Case	Case

Circular connector M12 x 1, 4-pin

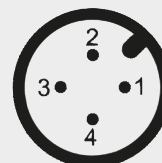

2-connector variant, for example, in combination with ELMS1 overload protection (F53S8).

Version in accordance with requirements for functional safety per 2006/42/EC Machinery Directive.

Pin assignment of analogue output with MIL connector

MIL connector				
Pin	mA/V, 3-wire		mA/V, 2-wire	
A	UB+	Channel 1	UB+ / S+	Channel 1
C	0V / S-		0V / S-	
D	S+	Channel 2	UB+ / S+	Channel 2
B	UB+		-	
E	0V / S-		-	
F	S+		0V / S-	Channel 2
G	-	-	-	-
Shield ⊕	Case	-	Case	-

MIL-CA3102E 16S-1P-B

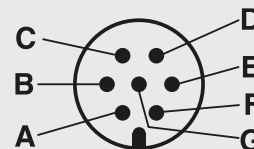

Pin assignment of analogue output for CANopen®

Circular connector M12 x 1, 5-pin	
Shield ⊕	1
Supply UB+ (CAN V+)	2
Supply UB- (CAN GND)	3
Bus signal, CAN-High	4
Bus signal, CAN-Low	5

Circular connector M12 x 1, 4-pin



Connect the cable shield to the force transducer housing.

In the case of accessory cables, the cable shield must be connected with the knurled nut and thus connected to the housing of the force transducer. When extending, only shielded and low capacitance cables should be used. The permitted maximum and minimum lengths of the cable are specified in ISO 11898-2.

A high-quality connection of the shielding must also be ensured.

Short description of signal jump electronics

Amplifier electronics 4 ... 20 mA or 0 ... 10 V for signal jump applications with 2-channel computer control

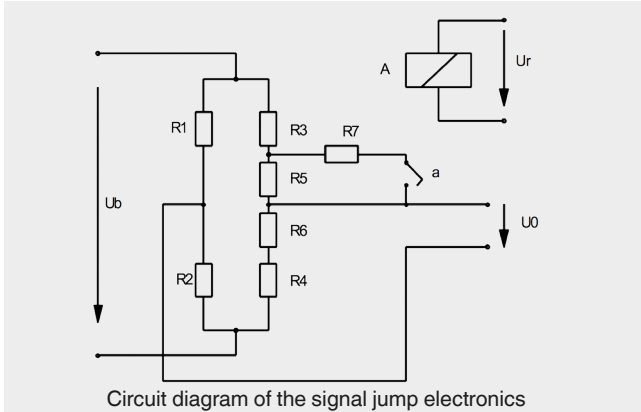

With these force transducers, four variable resistors (R1 ... R4) are connected together to form a Wheatstone bridge. When the measuring body deforms, the opposing resistors are stretched or compressed in the same way. This leads to a detuning of the bridge and a diagonal voltage U_0 .

The test resistor R7 is now important in connection with checking the subsequent amplifier circuit and the subsequent signal paths. This is switched parallel to the resistor R5 via the relay contact (a) as soon as the excitation voltage U_r of the relay A is present. The connection of the resistor R7 causes a defined, always constant, detuning of the zero point (diagonal voltage) of the Wheatstone bridge.

Compliance with functional safety

An external safety control system independent of the force transducer must monitor the safe functioning of the force transducer. The functional test with a signal jump of 4 mA / 2 V is executed at an interval of 24 hours. The safety control system activates the relay A, thus changing the output signal of the force transducer in a defined manner.

If the expected change in the output signal occurs, it can be assumed that the entire signal path from the Wheatstone bridge via the amplifier through to the output is functioning correctly. If this does not occur, then it can be concluded that there is an error in the signal path.

Moreover, the measuring signal should be checked by the safety control for the min. (A) and max. (B) signal value to ensure that any cable break or short-circuit that has occurred is detected.

The default setting of the force transducer with current output 4 ... 20 mA for overload detection is, for example:

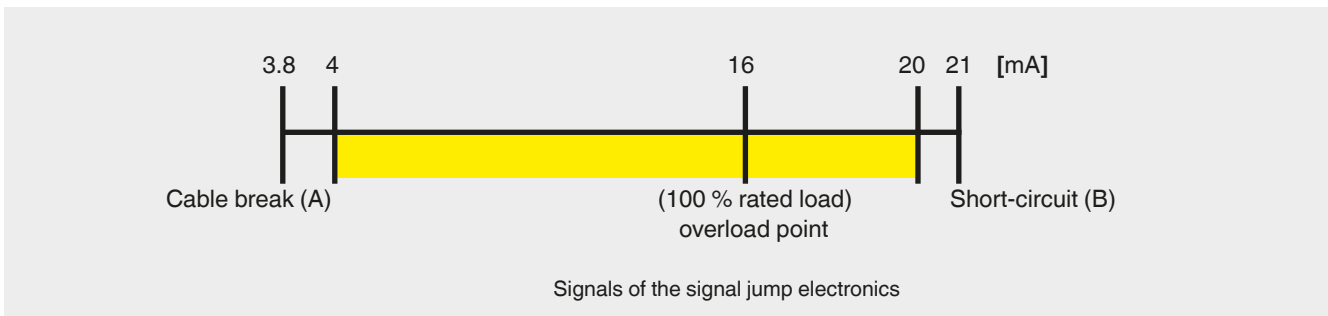

With a fixed signal jump of, for example, 4 mA, the test cycle can then be triggered, in any operating state, by activating the test relay. The upper measuring range limit of 20 mA will

never be reached and thus the checking of the signal jump is enabled.

© 06/2019 WIKA Alexander Wiegand SE & Co. KG, all rights reserved.
The specifications given in this document represent the state of engineering at the time of publishing.
We reserve the right to make modifications to the specifications and materials.