

Support force transducer With thin-film technology up to 2,060 kN Model F1305

WIKA data sheet FO 51.70

Applications

- Mobile cranes
- Concrete pumps
- Aerial platforms
- Truck-mounted cranes
- Fire engines with turntable ladders

Special features

- Measuring ranges 0 ... 280 kN to 0 ... 2,060 kN
- Insensitive to lateral forces
- Stainless steel version (corrosion-resistant)
- Integrated amplifier
- High long-term stability, high shock and vibration resistance, good reproducibility

Description

Support force transducers are specially designed for static and dynamic measuring requirements for outriggers of mobile machines. They serve for determining the supporting forces to allow the outriggers to be extended safely and efficiently. By measuring the supporting forces, the load capacity of the machines can be utilised more by 15 - 30 % because it is possible to adjust the load moment limitation to the current situation.

These force transducers are often used in mobile vehicles. The corresponding technical and regional approvals of these force transducers are, of course, available as options.



Support force transducer, model F1305

The force transducers of this series are made of high-strength, corrosion-resistant 1.4542 stainless steel, whose properties are particularly suitable for the transducer's application area. The CAN protocol provides the output signal.

Specifications per VDI/VDE/DKD 2638

Model	F1305
Rated force F_{nom} kN	280, 357, 420, 650, 730, 895, 1,150, 1,390, 2,060
Relative linearity error d_{lin} ¹⁾	up to 20 % F_{nom} : < 0.3 %, beyond < 0.5 % F_{nom}
Shear force influence d_q	< 1.5 % / 10 % of the acting force
Temperature effect on	
the characteristic value TK_c	0.2 % / 10 K
the zero signal TK_0	0.2 % / 10 K
Limit force F_L	130 % F_{nom}
Breaking force F_B	> 155 % F_{nom}
Long-term stability	typ. < 0.1 % /a
Permissible vibration loading F_{rb}	70 % F_{nom} (in accordance with DIN 50100)
Rated displacement (typical) s_{nom}	< 0.1 mm
Rated temperature range $B_{T, nom}$	-40 ... +80 °C
Storage temperature range $B_{T, nom}$	-55 ... +100 °C
Electrical connection	CANopen [®] , 5-pin
Output signal	CANopen [®] Protocol in accordance with CiA 301, instrument profile 404, communication services LSS (CiA 305), configuration of the instrument address and baud rate Sync/Async, Node/Lifeguarding, heartbeat; zero point and span ± 10 % adjustable via entries in the object directory ²⁾
Current/power consumption	CANopen [®] : < 1 W
Supply voltage	DC 12 ... 30 V for CANopen [®]
CAN insulation resistance	> 2 G Ω
Load	$\leq (U_B - 10 \text{ V}) / 0.024 \text{ A}$ for current output > 25 k Ω for voltage output
Ingress protection (per IEC/EN 60529)	IP67
Vibration resistance	20 g, 100 h, 50 ... 150 Hz per DIN EN 60068-2-6
Shock resistance	DIN EN 60068-2-27
Immunity	In accordance with DIN EN 61326-1/DIN EN 61326-2-3 (optional EMC-reinforced versions)
Optional	Certificates, strength verifications, 3D CAD files (STEP, IGES) on request
Weight in kg	
■ 280 kN	3
■ 357 kN	3
■ 420 kN	3.5
■ 650 kN	4.5
■ 730 kN	5.5
■ 895 kN	10.5
■ 1,150 kN	10.5
■ 1,390 kN	14.5
■ 2,060 kN	30

1) Relative linearity error is specified in acc. with Directive VDI/VDE/DKD 2638 Chap. 3.2.6.

2) Protocol in accordance with CiA 301, instrument profile 404, communication service LSS (CiA 305). CANopen[®] and CiA[®] are registered community trademarks of CAN in Automation e. V.

Dimensions

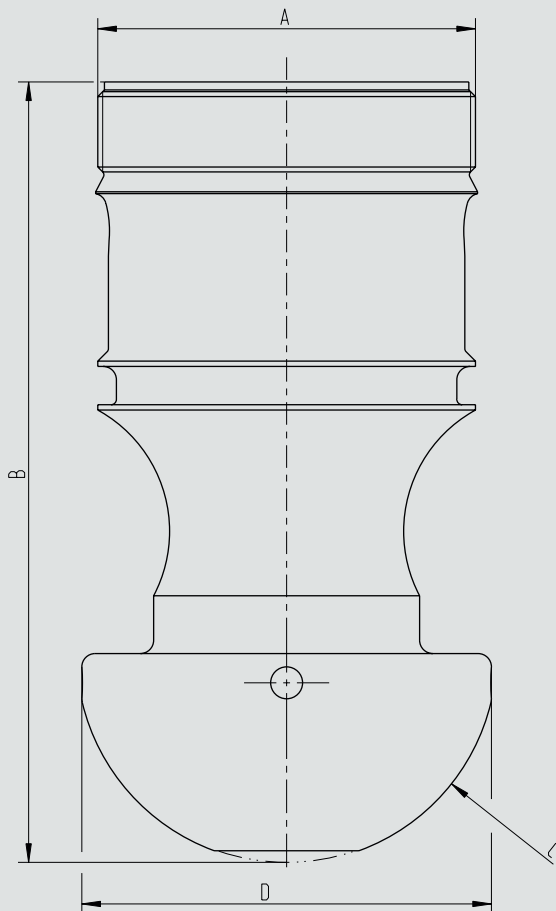

All dimensions in mm.

Rated force in kN	A	B	C	D
280	M71 x 1.5	147	Ø79	Ø77
357	M71 x 1.5	147	Ø79	Ø77
420	M76 x 1.5	152	Ø79	Ø77
650	M85 x 1.5	157.5	Ø79	Ø77
730	M100 x 1.5	167.5	Ø79	Ø77
895	M120 x 1.5	213	Ø118	Ø116.5
1,150	M130 x 1.5	213	Ø118	Ø116.5
1,390	M150 x 1.5	228	Ø118	Ø116.5
2,060	M150 x 1.5	246	Ø140	Ø138

Pin assignment, CANopen®

Circular connector M12 x 1, 5-pin	
Shield ⊕	1
Supply UB+ (CAN V+)	2
Supply UB- (CAN GND)	3
Bus signal, CAN-High	4
Bus signal, CAN-Low	5

Circular connector
M12 x 1, 5-pin



Connect the cable shield to the case of the force transducer. In the cables of the accessories, the cable shield is connected by means of the knurled nut, thus connecting it to the case of the force transducer. When using extensions, only shielded and low-capacitance cables should be used. The permitted maximum and minimum lengths of cable are defined in ISO 11898-2. Care should be taken also to ensure a high-quality connection of the shielding.

Ordering information

Model / Measuring range / Relative linearity error / Output signal / Supply voltage / Accuracy / Temperature range / Process connection / Electrical connection

© 2020 WIKA Alexander Wiegand SE & Co. KG, all rights reserved.
The specifications given in this document represent the state of engineering at the time of publishing.
We reserve the right to make modifications to the specifications and materials.