

Hydraulic compression force transducer NS 3 x 16, 3-jaw clamping force test instrument up to 470 kN Model F1112

WIKA data sheet FO 52.25

Applications

- Measurement of clamping force in three-jaw chucks
- Equipment manufacturing
- Construction of jigs and fixtures
- Special machine building
- Measuring and control systems

Special features

- Measuring ranges 0 ... 2.5 kN to 0 ... 470 kN
- Relative linearity error $\pm 1.0 \dots 1.6 \% F_{nom}$ with analogue pressure gauge, $\pm 0.5 \% F_{nom}$ with digital pressure gauge or pressure sensor¹⁾
- Piston stroke $\leq 0.5 \text{ mm}$, force introduction as total clamping force
- Operates without supply voltage
- 5-year leak-tightness warranty²⁾



Hydraulic compression force transducer, model F1112

Description

The hydraulic force transducer model F1112, version NS 3 x 16, is suited for regular testing of the clamping force in 3-jaw chucks. It thereby ensures optimum use of the clamping jaws.

Hydraulic force measurement is a simple way to capture and display the forces occurring in various applications. The force is measured using the principle of hydraulics: The force acting on a piston leads to a pressure increase that can be visualised on a connected display instrument. The scale of the display instrument can be defined in various units (e.g. N, kN, kg, t).

Leak-tightness warranty

The warranty on leak tightness of the hydraulic force measuring unit was extended to 5 years²⁾. A force transducer that starts to leak within this period will be repaired free of charge.

1) For rated loads below 500 N, the accuracy is $\pm 1.6 \% F_{nom}$ for all connected measuring instruments.

2) Use of the force measuring unit as intended is a prerequisite for the extended 5-year warranty.

Specifications per VDI/VDE/DKD 2638

Model F1112	
Rated force F_{nom}	0 ... 2.5 kN to 0 ... 470 kN
Nominal size	NS 3 x 16
Display <ul style="list-style-type: none"> ■ Standard ■ Option 	Pressure gauge 232.57 (NS 100) Digital pressure gauge DG-10 Pressure sensor (on request)
Relative linearity error d_{lin} <ul style="list-style-type: none"> ■ Standard ■ Option 	$\leq \pm 1.6 \% F_{nom}$ (analogue display) ¹⁾ $\leq \pm 0.5 \% F_{nom}$ (pressure sensor/digital pressure gauge) ¹⁾
Limit force F_L	100 % F_{nom}
Breaking force F_B	> 130 % F_{nom}
Force introduction <ul style="list-style-type: none"> ■ Standard ■ Option 	Total clamping force Clamping force per jaw
Rated displacement s_{nom}	< 0.5 mm
Rated temperature range $B_{T, nom}$	-10 ... +50 °C
Ingress protection (per EN/IEC 60529)	IP65
Case	Stainless steel
Piston	Stainless steel
Mounting type <ul style="list-style-type: none"> ■ Standard ■ Option 	Adapter L = 50 mm Capillary Measuring hose for "separation without any losses"
Fill fluid	Glycerine/water 70 %/30 %
Weight in kg <ul style="list-style-type: none"> ■ with pressure gauge 232.57 (NS 100) ■ with digital pressure gauge DG-10 	4.1 3.9

1) For rated forces below 500 N, the relative linearity error is $\pm 1.6 \% F_{nom}$ for all connected measuring instruments.

Dimensions in mm

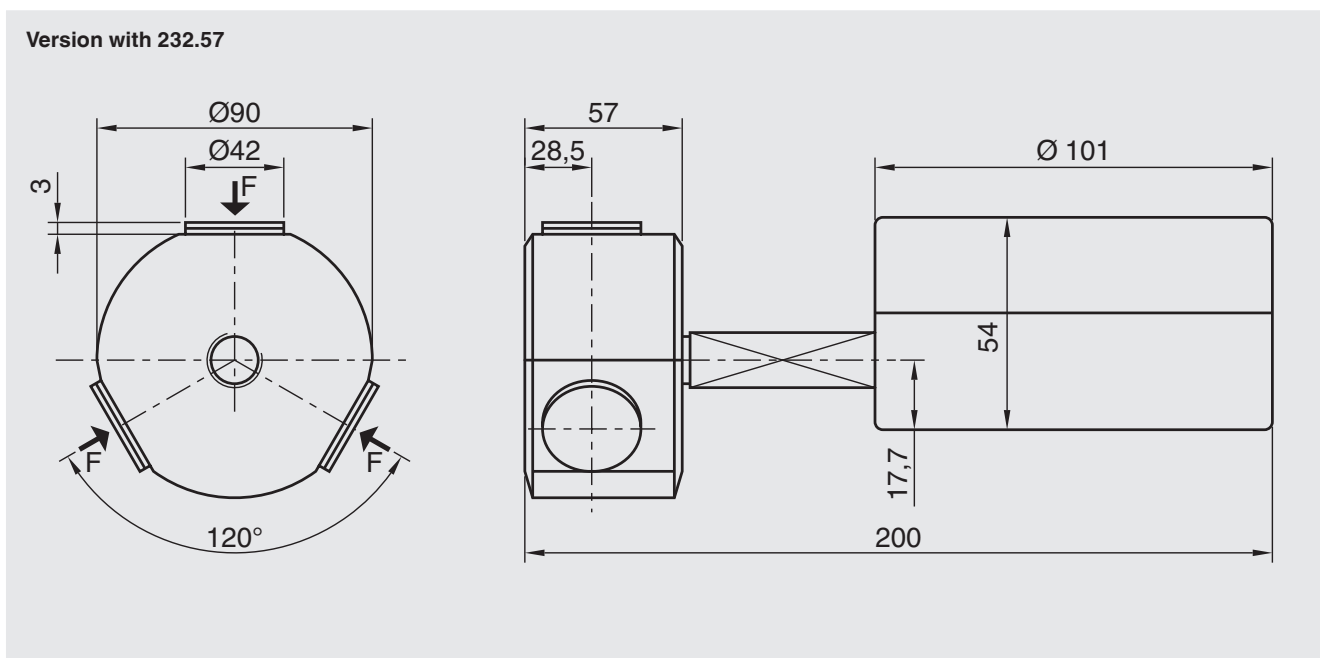

The sealed threaded connections of the hydraulic force transducer must not be loosened!
 Non-compliant handling invalidates the warranty and a measuring function is no longer assured.

Version		Display		Options	
Rated force	System pressure	232.57	DG-10	Measuring hose DN 2 [max. L ¹⁾]	Capillary [max. L ¹⁾]
kN	bar			m	
2.5	6	■	-	0.5	1.0
5	10	■	-	1.0	2.0
7.5	16	■	-	1.0	2.0
10	20	-	■ ²⁾	1.5	2.0
12	25	■	-	1.5	2.0
19	40	■	-	1.5	2.0
25	50	-	■	2.0	2.0
30	60	■	-	2.0	2.0
50	100	■	■	2.0	2.0
75	160	■	■	2.0	4.0
120	250	■	■	3.2	4.0
190	400	■	■	3.2	6.0
280	600	■	■	3.2	6.0
470	1,000	■	-	-	6.0
Other rated loads and versions on request					

■ = possible selection

1) For a rated force below 500 N, the relative linearity error is $\pm 1.6\%$ F_{nom} for all connected measuring instruments.

2) Relative linearity error $< \pm 1.0\%$ F_{nom}

© 2019 WIKA Alexander Wiegand SE & Co. KG, all rights reserved.
The specifications given in this document represent the state of engineering at the time of publishing.
We reserve the right to make modifications to the specifications and materials.

WIKA data sheet FO 52.25 · 07/2019

Page 3 of 3

Your WIKA Sales Partner



ICS Schneider Messtechnik GmbH
Briesestrasse 59
D-16562 Hohen Neuendorf / OT Bergfelde
Tel.: +49 3303 5040-66
Fax: +49 3303 5040-68
E-Mail: info@ics-schneider.de



WIKAL Alexander Wiegand SE & Co. KG
Alexander-Wiegand-Straße 30
63911 Klingenberg/Germany
Tel. +49 9372 132-0
Fax +49 9372 132-406
info@wika.com
www.wika.com