

User manual IMH-1U

Measuring inputs: Direct voltage, Direct current, Pt100, Pt1000, Thermocouple,
Frequency, Counter



Technical features:

- red display of -199...999 digits (intern -1999 to 9999)
- digit height approx. 7 mm
- minimum/maximum-value recording
- 9 adjustable supporting points
- display flashing at threshold value exceedance/undercut
- tara function
- programming interlock via access code
- plug-in screw terminal
- optional: analog output 0-10 VDC, 0/4-20 mA
- optional: interface RS232 / RS485 / Bluetooth (in preparation)
- optional: sensor supply incl. digital input
- optional: two relay outputs **or** two PhotoMos outputs
- optional: two relay outputs **and** two PhotoMos outputs
- optional: data logger (in preparation)
- accessories: PC-based configuration kit PM-TOOL with CD and USB adapter

Contents

1. Brief description	5
2. Assembly	5
3. Electrical connection and connection examples	6
3.1 Terminal assignment	6
3.2 Connection examples	7
3.2.1 Voltage / Current	7
3.2.2 Temperature: Pt100 / Pt100 / Thermocouple	9
3.2.3 Frequency / Rotational speed	10
3.2.4 Counter	12
3.2.5 Digital input	13
4. Description of function and operation	13
4.1 Operation	13
4.2 Power-on	15
4.3 Programming software PM-TOOL	15
6. Parameterization	16
6.1 Program structure	16
6.2 Selection of input signal, tyP	17
6.2.1. Voltage/Current, Vol, AMP	18
Setting of final and initial value, End, En.1, OFS, OF.1	
Setting of decimal point, dot	
Zero point staedying of the input signal, ZEr	
Taring value, tAr	
Input of supporting points for linearization of the measuring signal, SP.C	
6.2.2. Temperature	19
6.2.2.1 Pt100, Pt1000, Pt.S	19
Temperature indication in °C/°F, Unt	
Impedance matching, OFS	
6.2.2.2 Thermocouple, tHe	20
Temperature indication in °C/°F	
Impedance matching, OFS	

Contents

6.2.3. Pulse measuring, IMP	20
6.2.3.1. Frequency, FrE	21
Frequency range, rnG	
Triggering of pulses, i.tY	
Filter, FIL	
Pulse per turn, ppt	
Setting of final and initial frequency, End, En.F, OfS, OF.F	
Setting of decimal point, dot	
Zero point steadying of the input signal, ZEr	
Taring value, tAr	
Input of supporting points for linearization of the measuring signal, SP.C	
6.2.3.2. Rotational speed, trn	23
Triggering of pulses, l.tY	
Filter, FIL	
Pulse per turn, PPt	
Time base, tIM	
Setting the decimal point, dot	
6.2.3.3. Counter – upwards/downwards, C.uP, C.dn	24
Triggering of pulses, i.typ	
Counter basis / input signal, C.bA	
Flank, EdG	
Prescaler, PrE	
Final display value and final pulse value, End,En.C	
Reset value, rSt	
Setting of decimal point, dot	
6.3. General device parameters, Gen	26
Setting of the display time, dl.t	
Setting of the measuring time, SEC	
Setting of the moving average value, GLM	
Arithmetic functions, ArI	
Display overflow/underflow behaviour, OVr	
Minimum/Maximum value adjustment, dl.L,dl.H	
Brightness control, brt	

Contents

Assignment of functions to the navigation keys, tSt

Assignment of functions to the digital input, dl.F

6.4 Analog output parameters, Out **29**

Supply source, A.In

Select analog output signal, A.rA

Setting of analog end and initial value, A.En, A.OF

Overflow/underflow behaviour of analog output, A.FL

6.5 Interface parameters, Ser **30**

Modbus address, Adr

Modbus mode, Mod

Modbus timeout, t.ou

Safety code Bluetooth, Pin

6.6 Data logger (in preparation)

6.7 Alarm parameters, AL **31**

Trigger, x.Sr

Threshold value behaviour, x1.fu, a2.fu

System error, x.bH

Alarm output, x.rE

Setting of the switching threshold, x.LI

Setting of the hysteresis, x.HY

Upper threshold value, x.HI

Lower threshold value, x.Lo

Delayed release, x.oF

On-delay, x.on

Alarm flashing, x.FL

Alarm acknowledgement, x.Ac

Alternative threshold value, x.AL

6.8 Totalizer, tot **33**

Totalizer state, t.FA

Time base, t.bA

Factor, FAC

Setting of the decimal point, t.dt

Contents

6.9. Saftey parameters for blocking the parameterization, Sec	34
Master code – assignment of an individual numerical code, A.Co	
User code – assignment of an individual numerical code, U.Co	
User level, Lev	
Activation/Deactivation of the programming interlock, run	
7. Modbus protocol	36
8. Reset to default values	41
Reset the parameters to the delivery state	
9. Technical data	42
10. Safety instructions	45
11. Error elimination	46

1. Brief description

The **IMH-1U** is a 3-digit digital indicator for top hat rail mounting and is used to measure voltage/current, temperature and frequency. The configuration happens via 3 front keys or via optional PC-Software PM-TOOL. An integrated programming interlock prevents unwanted changes of parameters and can be unlocked via an individual code. Optionally, the display can be extended with a sensor supply, an analogue output, an interface RS232 / RS485 (Modbus protocol), as well as 4 switching points. A data logger and a Bluetooth interface are in preparation.

2. Assembly

Please read the *safety instructions* on page 45 before assembly and keep this manual for future reference.

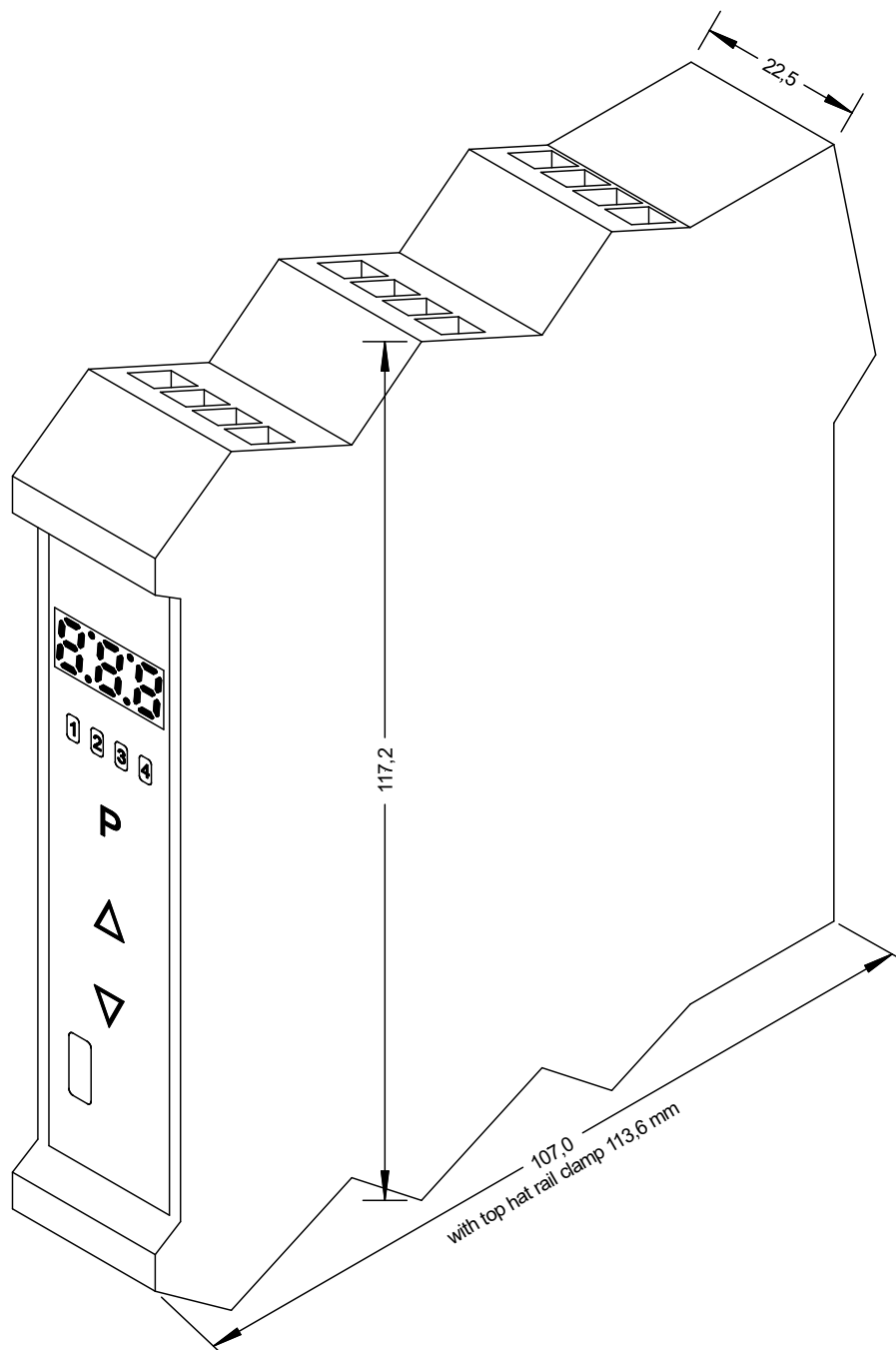

The indicator MH-1H is already prepared for a top hat rail mounting. Simply place the device on the top hat rail in the correct position. Pressing the orange lever down will automatically lock the display.

3. Electrical connection and connection examples

3.1 Terminal assignment

Type MH-1U1R3A.000X.760A

Supply 24 VDC galv. isolated

Type MH-1U1R3A.000X.S60A

Supply 100-240 VAC / DC \pm 10%

Type MH-1U1R3A.000X.W60A

Supply 15-40 VDC galv. isolated / 20-30 VAC

Terminal 1

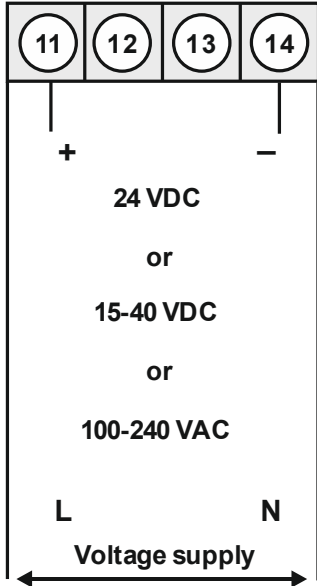

Terminal 6

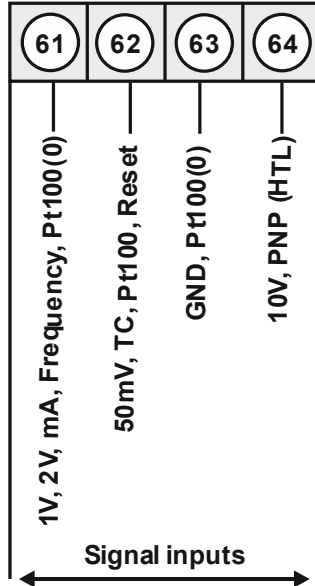

Options:

Terminal 2

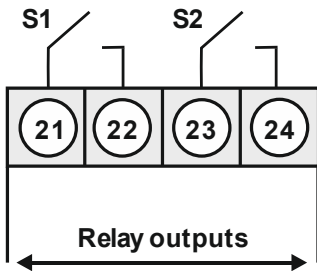

Terminal 3

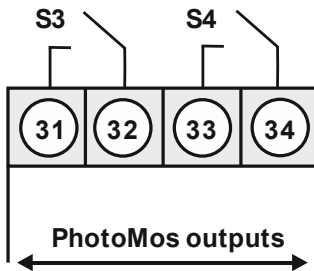

Terminal 5

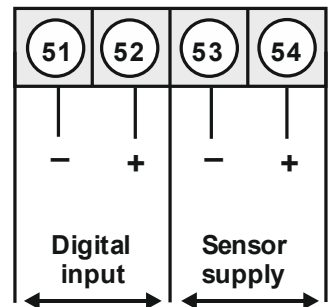

Terminal 4

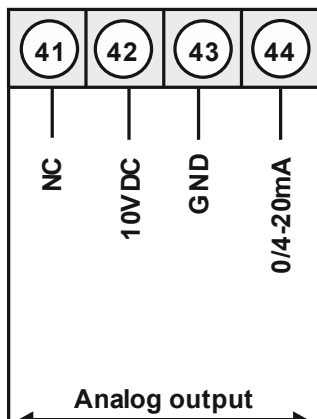

alternative to analog output

Terminal 4

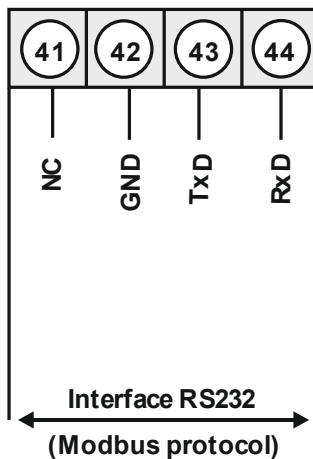

or

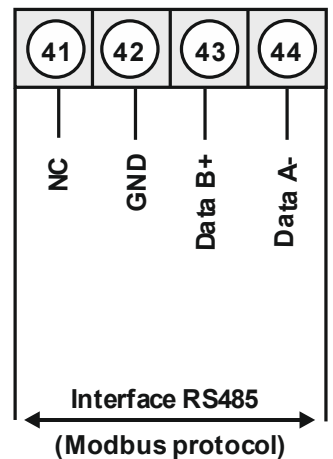

3.2 Connection examples

Below you will find some connection examples in which practical applications are shown:

3.2.1 Current/Voltage

2-wire sensor 4-20 mA

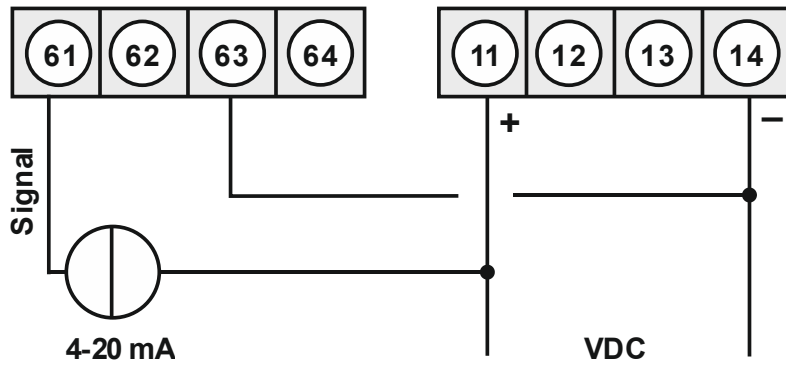

2-wire sensor 4-20 mA in combination with 24 VDC sensor supply

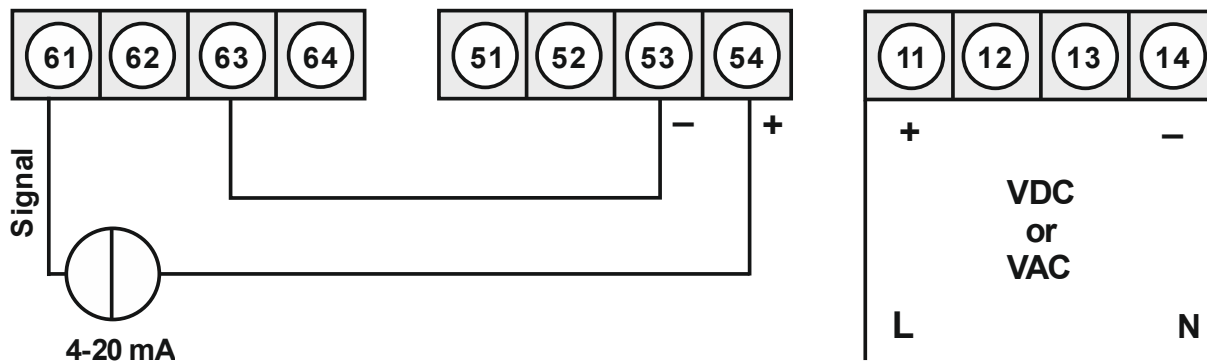

3-wire sensor 0/4-20 mA

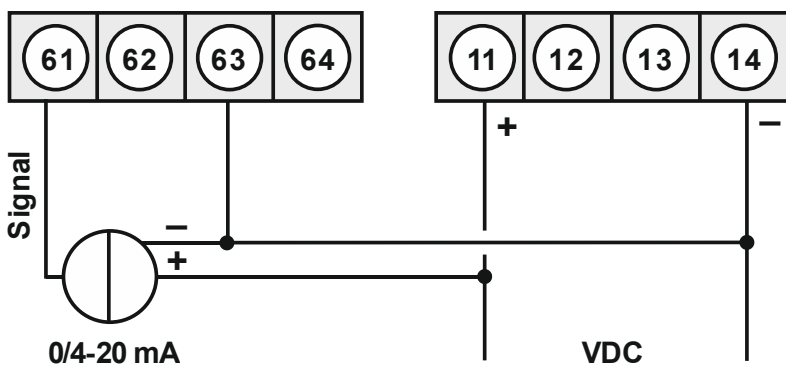

3-wire sensor 0/4-20 mA in combination with 24 VDC sensor supply

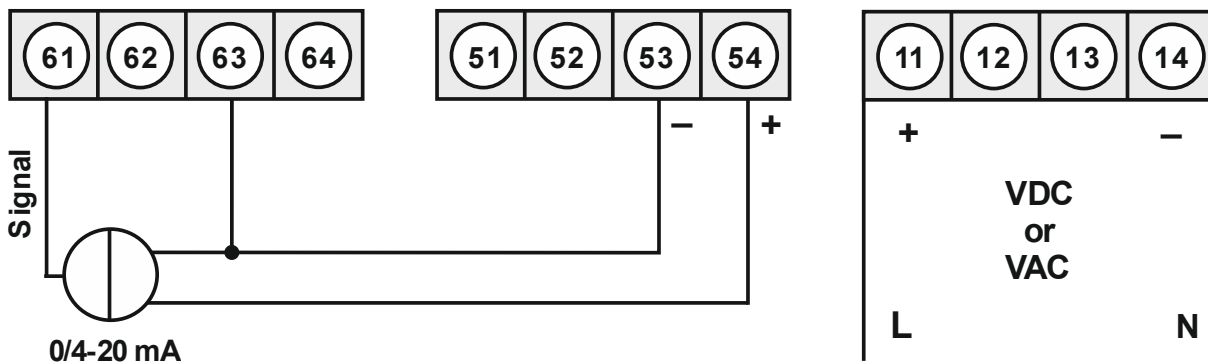

3-wire sensor 0-1/2-10 V

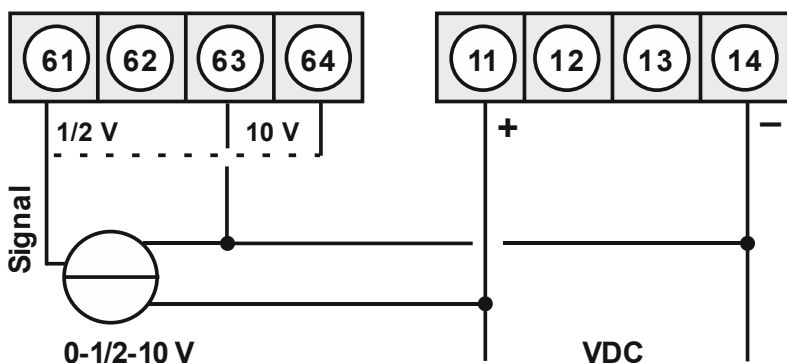

3-wire sensor 0-1/2-10 V in combination with 24 VDC sensor supply

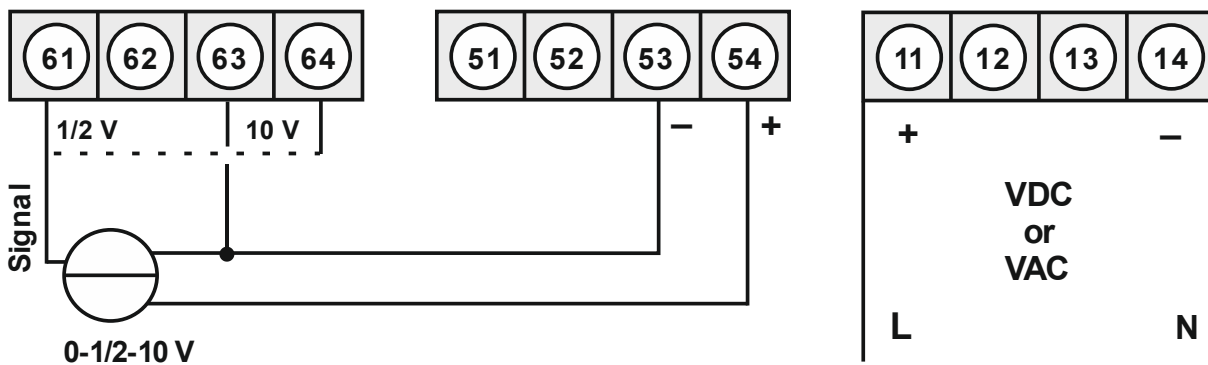

4-wire sensor 0-1/2-10 V, 50 mV

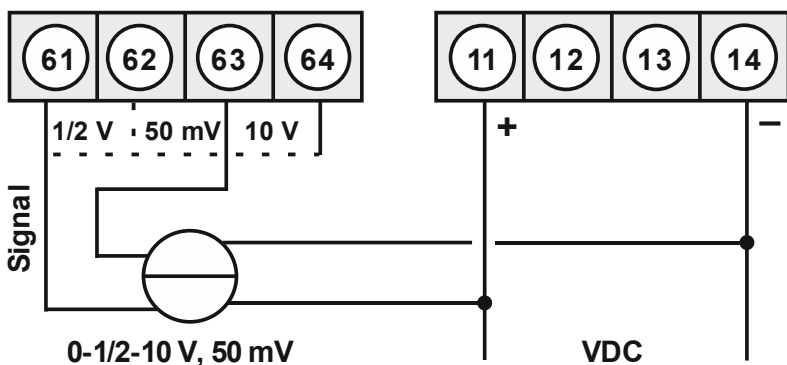

4-wire sensor 0-1/2-10 V, 50 mV in combination with 24 VDC sensor supply

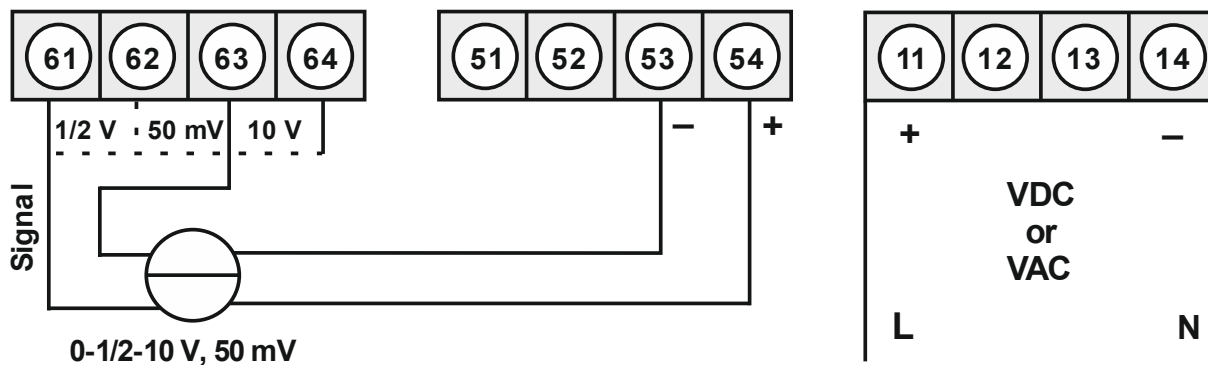

3.2.2 Temperature

Pt100 3-wire

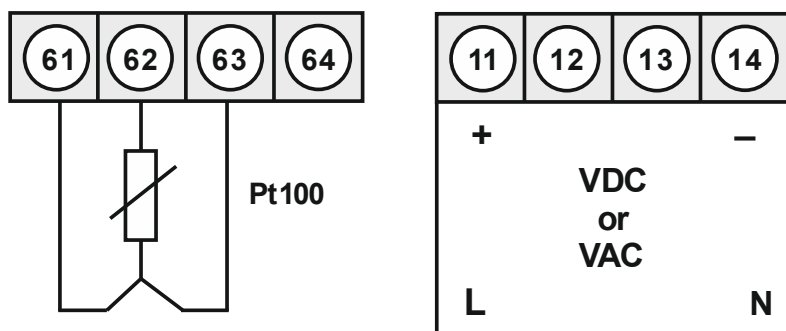

Pt1000 2-wire

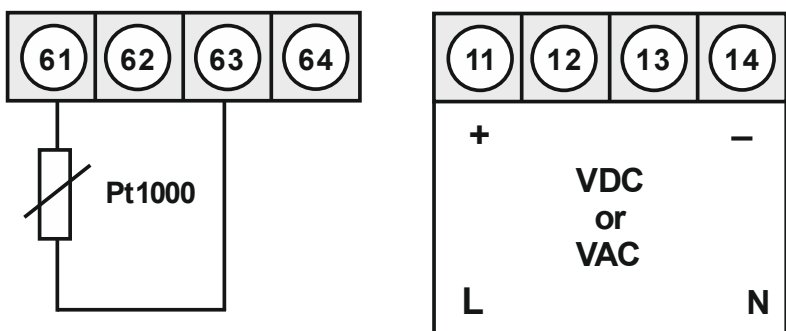

Thermocouple

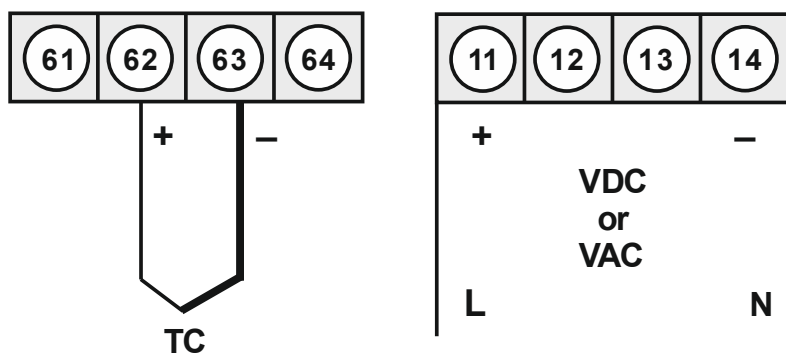

3.2.3 Frequency / Rotational speed

Sensor with TTL-output

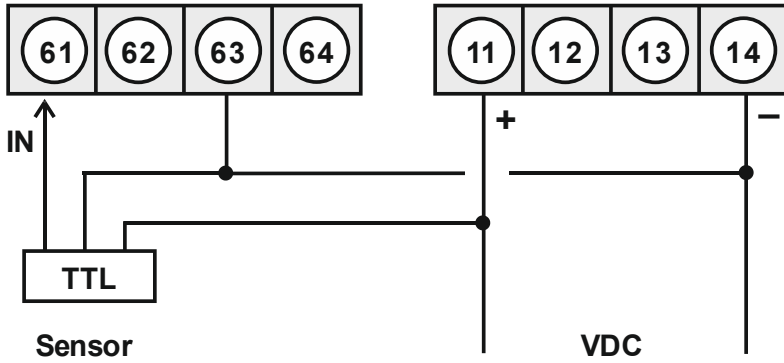

Sensor with TTL-output in combination with 24 VDC sensor supply

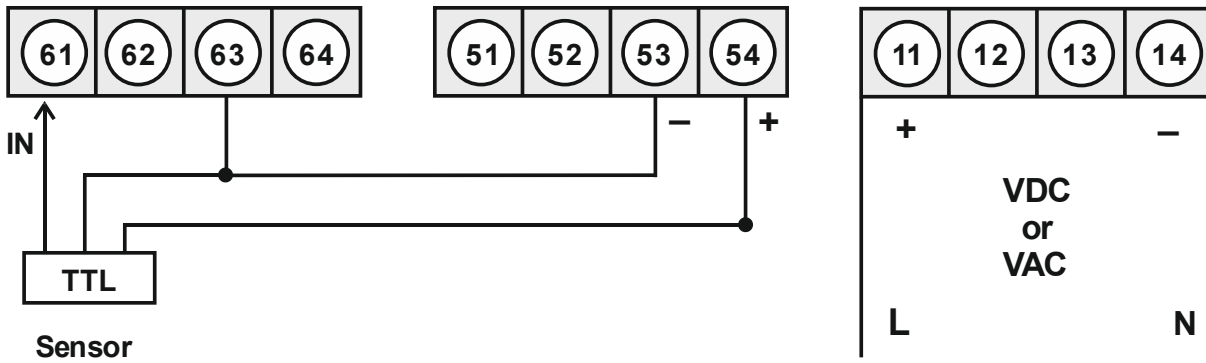

Sensor with PNP-output

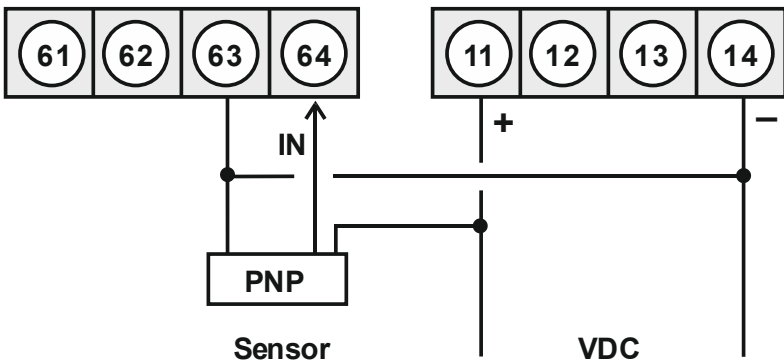

Sensor with PNP-output in combination with 24 VDC sensor supply

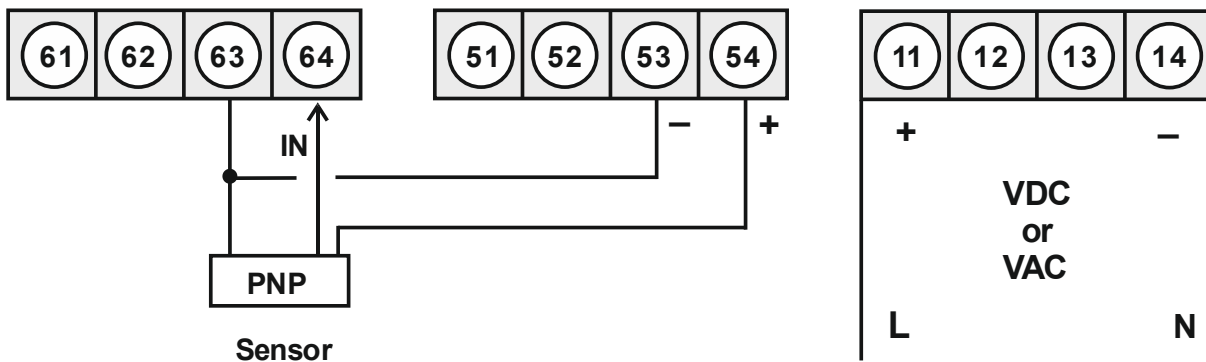

Sensor with NPN-output

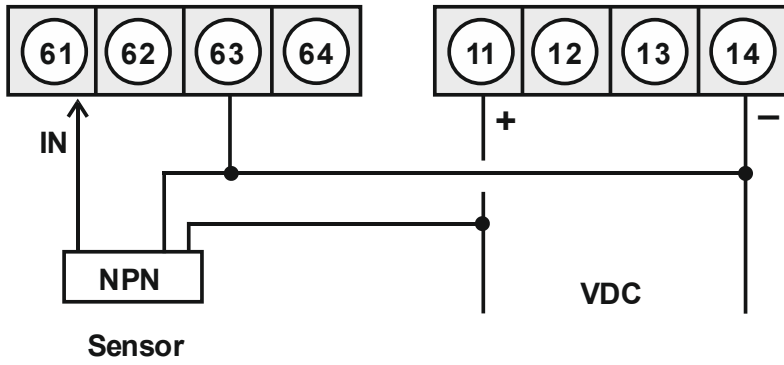

Sensor NPN-output in combination with 24 VDC sensor supply

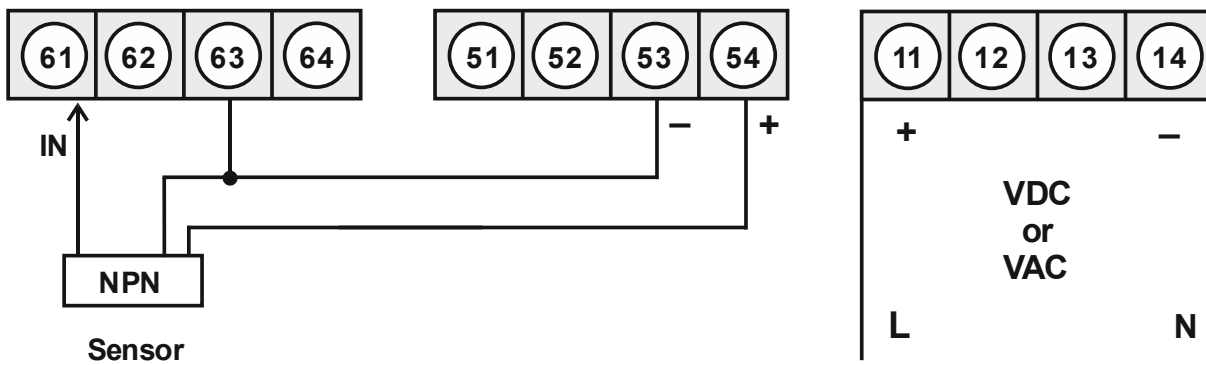

Sensor with NPN-output and required external resistance

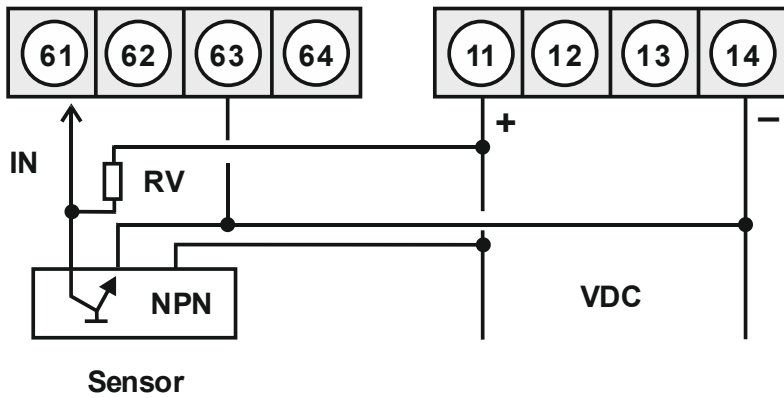

Sensor with NPN-output and required external resistance in combination with 24 VDC sensor supply

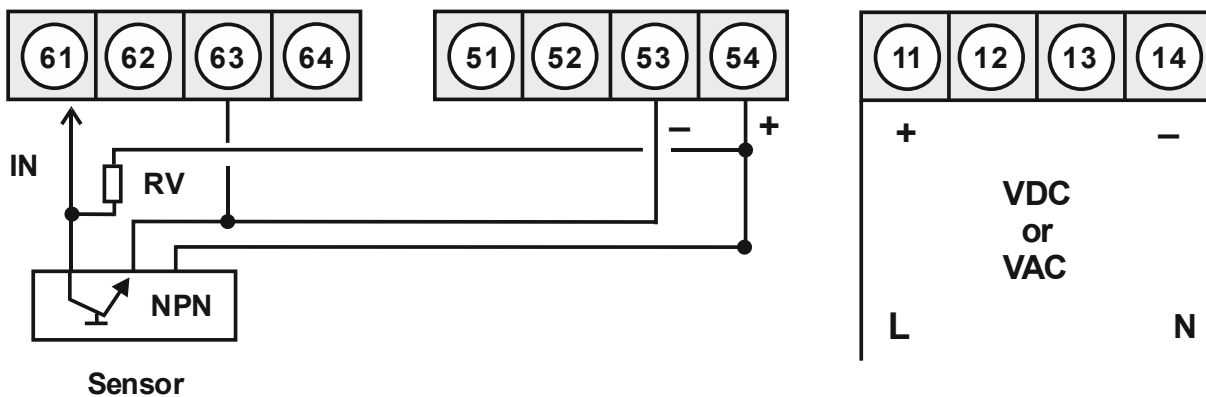

Sensor with PNP-output and external resistance circuit

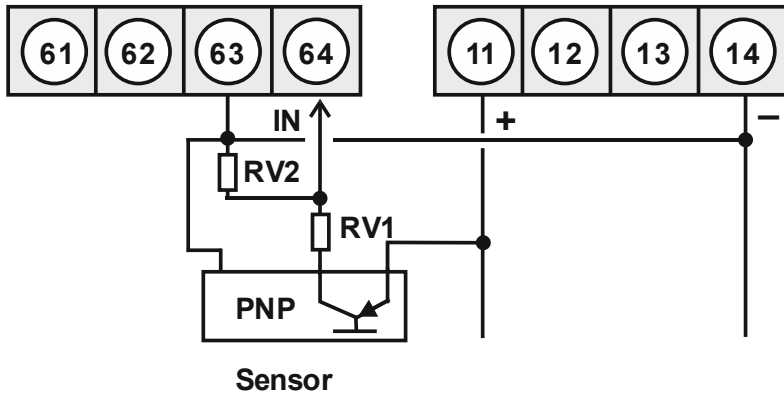

Sensor with PNP-output, external resistance circuit in combination with 24 VDC sensor supply

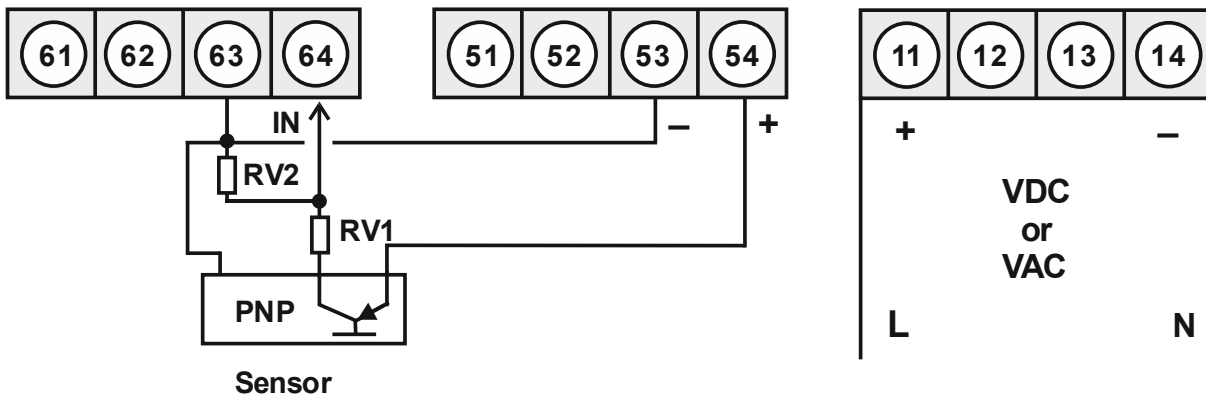

3.2.4 Counter

When used as a counter, use the frequency / rotational speed connection examples and the reset input below.

Manual reset with external push-button:

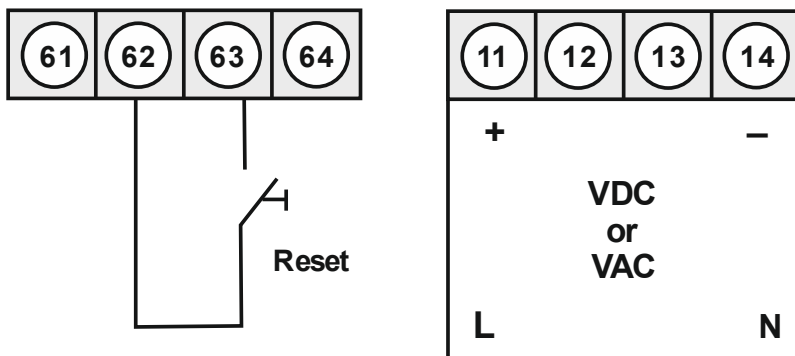

3.2.5 Digital input

Devices with digital input, sensor supply or external voltage source:

IMH-1U with digital input in combination with 24 VDC sensor supply

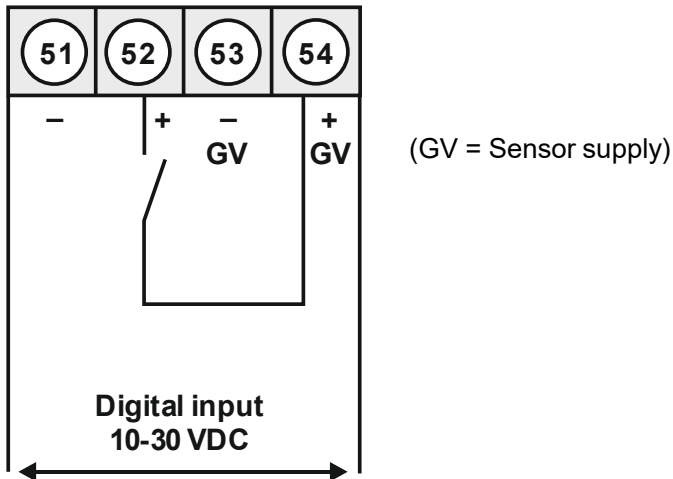

IMH-1U with digital input in combination with external voltage source

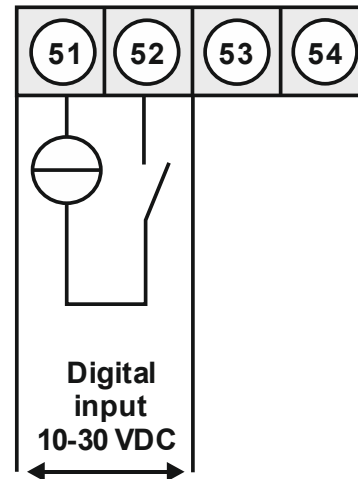

4. Description of function and operation

4.1 Operation

The operation is selectable in 2 presentations: cryptic or numerical (Program numbers). A changeover occurs when leaving the program by selecting **run**, with subsequent confirmation of **UnL** for the cryptic menu or **FLt** for the numeric menu. Furthermore, the parameter lock can be activated there by selecting **LOC**.

The display has 3 push buttons with which you can parameterize the device and call up stored functions during operation. Functions, that can be adjusted or changed are always signalled with a flashing display. The settings made in the parameter level are always confirmed with **[P]** and thus saved. However, the indicator also automatically saves all adjustments and switches to operating mode if no further keypress occur within 30 seconds. By simultaneously pressing the two navigation keys **[▲]** & **[▼]** the configuration mode can be interrupted.

Key symbol	Function in operating mode	Function at parameterization
Program key [P]	Use the program key [P] to change to the parameterization.	Change to a lower parameter level or to the deposited value.
Minus key [▼]	The minus key [▼] can be used to call up the minimum value or to change a lower limit depending on the set key function.	Change between the parameters and change parameters in the value level.
Plus key [▲]	Depending on the set key function, the maximum value can be called up or an upper limit value can be changed with the plus key [▲].	Change between the parameters and change parameters in the value level.

A switched-on relay or an activated switching point is optically signalled by a flashing of the respective switching point LED below the 7-segment display. An display overflow / underflow is represented by 3 bars: "- - -".

Example: Setting of device parameters, e.g. selection of the input signal.

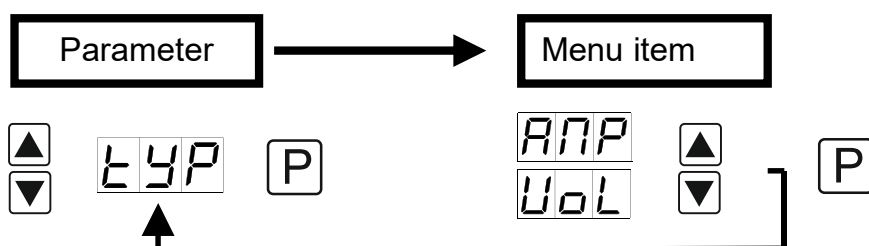

Example: Setting of numerical values, e.g. limit value of measuring range

3-digit numerical value, e.g. 100

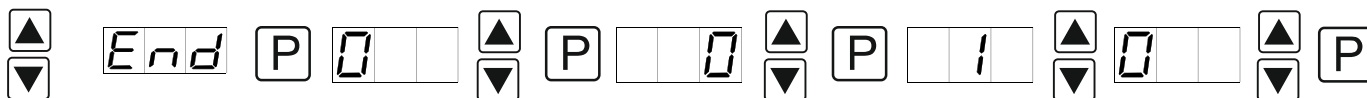

Numerical values are adjusted from the smallest to the largest digit with [▲] [▼] and confirmed digit by digit with [P]. A minus sign can only be parameterized in the most significant place. After the last digit, the display changes back to the menu level.

3-digit numerical value, e.g. 1000 (presentation 1'00)

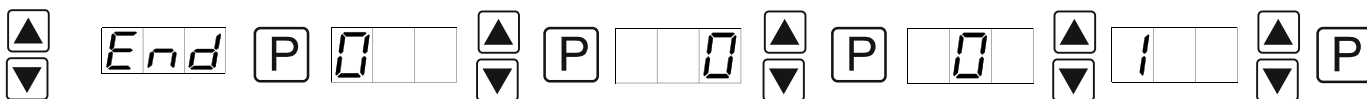

If the end value has been parameterized to a thousandth value, from the indication of the thousandth value the device divides the display by 10 and displays it as follows: 1'00 for 1000. The last digit is rounded commercially.

4.2 Power-on

After completing the installation, you can put the device into operation by applying the supply voltage. First, check all electrical connections again for their correct connection.

Starting sequence

During the power-on process, the segment test (8 8 8) and the message of the software type are displayed for 1 second and then for the same time, the software version. After the starting sequence, the change to the operating or display mode follows.

4.2 Parameterization software PM-TOOL:

Component including the software on CD is a USB cable. The connection is made via a USB port on the front panel to the PC side.

System requirements: PC with USB interface

Software: Windows XP, Windows VISTA

With this tool, the device configuration can be created, skipped and stored on the PC. The easy-to-use program interface allows the parameters to be changed, whereby the mode of operation and the possible selection options are preset by the program.

ATTENTION!

When parameterizing with an applied measuring signal, make sure that the measuring signal has no ground reference to the programming plug. The programming adapter is galvanically not isolated and directly connected with the PC. By reversing the polarity of the input signal, a current can flow through the adapter and destroy the device and connected components!

6. Parameterization

6.1. Program structure

Via the main menu you can choose from 8 subgroups. The parameterization of the corresponding function takes place in the subgroups.

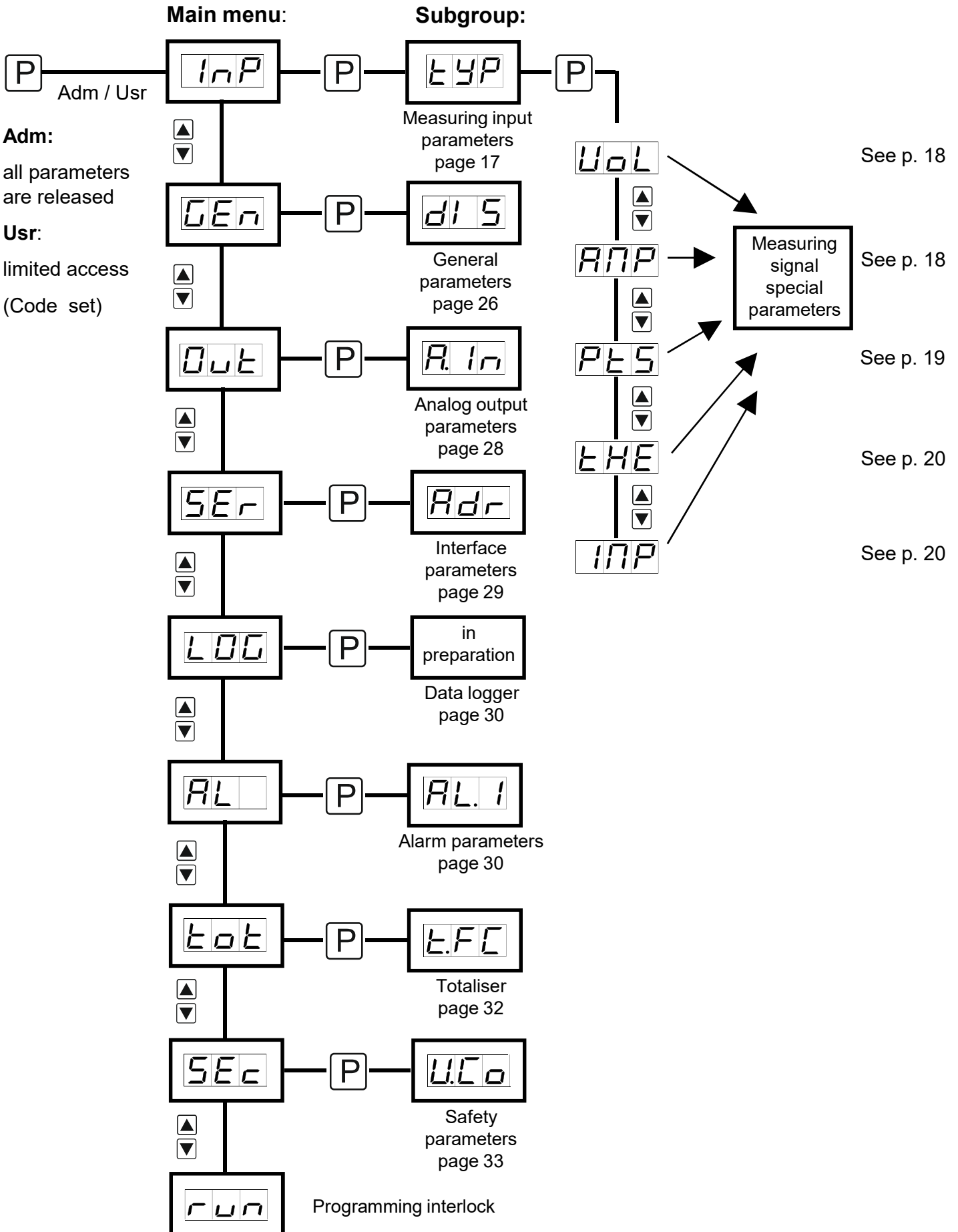

run: Activation / Deactivation of programming interlock

Select with [**▲**] [**▼**] between deactivated key lock **UnL** (factory setting) and activated key lock **LoC**. If **LoC** was selected, the keypad is locked. In order to return to the menu level, [**P**] must be pressed for 3 seconds in operating mode. The now appearing code (factory setting 000) is entered with [**▲**] [**▼**] and [**P**] and unlocks the keyboard. An incorrect entry is displayed with **FAL**.

In **LoC** mode, the display can not be reset, this shall additionally ensure a regular operation.

UnL: all parameters are open.

LoC: parameterization is locked

6.2 Selection of input signal: tYP

During type setting, an assignment of the input variants takes place, you can choose between the 5 input types voltage, current, Pt100(0), thermocouple and pulse signal.

Measuring input types:

The following measuring input types are available:

In numerical programming, E.00 stands for the selection of the input parameter and consecutively the numbers 0-23 for the desired input signal. The cryptic representation is described separately for each input type.

- **Voltage „VoL“**
 - 0: Standard signal 0...10 VDC „10U“
 - 1: Low voltage 0...2 VDC „2U“
 - 2: Low voltage 0...1 VDC „1U“
 - 3: Low voltage 0...50 mVDC „50m“
 - 4: Sensor calibration 0...10 V „Sen“
- **Current „AMP“**
 - 5: Standard signal 0...20 mA „0.20“
 - 6: Standard signal 4...20 mA „4.20“
 - 7: Sensor calibration 0...20 mA „Sen“
- **Pt-Sensor (PT100/PT1000) „Pt.S“**
 - 8: PT100 3-wire -50.0...200.0°C / -58.0...392.0°F „Pt.L“
 - 9: PT100 3-wire -200...850.0°C / -328...1562°F „Pt.H“
 - 10: PT1000 2-wire -200...850°C / -328...1562°F „Pt.t.“
- **Thermocouple „tHE“**
 - 11: Thermocouple type L „tY.L“
 - 12: Thermocouple type J „tY.J“
 - 13: Thermocouple type K „tY.K“
 - 14: Thermocouple type B „tY.b“
 - 15: Thermocouple type S „tY.S“
 - 16: Thermocouple type N „tY.n“
 - 17: Thermocouple type E „tY.E“
 - 18: Thermocouple type T „tY.t“
 - 19: Thermocouple type R „tY.r“
- **Pulse measuring „IMP“**
 - 20: Frequency „FrE“
 - 21: Rotational speed 1/min „trn“
 - 22: Counter upwards „C.uP“
 - 23: Counter downwards „C.dn“

6.2.1 Voltage input / current input parameters: Vol, AmP

A setting of e.g. 751 in the display corresponds to a setting of 7510.

VoL: Available are 4 voltage signals and 1 signal for the sensor calibration on the measuring section: **0-10 V**, **0-2 V**, **0-1 V**, **0-50 mV**, **SEn**

AMP: Here, select between the following signals: **0-20 mA**, **4-20 mA**, **Sen**

For the measuring inputs voltage (0-10 V) / current (0-20 mA), in addition to the preset input signals, a calibration can be made directly at the measuring section. For this, select **SEn** as input variant, now you can choose between **nOC** (no calibration) and **CAL** (calibration). With **nOC**, the previously set display value is adopted, with **CAL** the adjustment takes place via the measuring section and the analog input value is accepted.

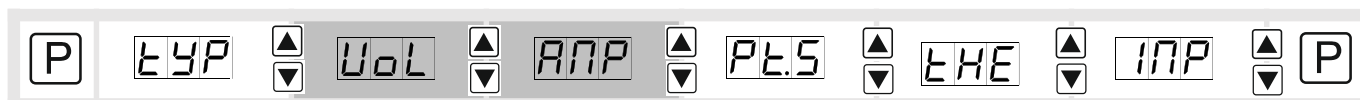

Parameter	Menu item						Default
VoL	UoL	10U	2U	1U	50n	SEn	10U
AMP	ANP	0.20	4.20	SEn			0.20

Parameter		Menu item				Default		Description
UnL	FLt	UnL	FLt	UnL	FLt	UnL	FLt	
End	E.11	-1999	-1999	9999	1000	1000	1000	Upper range value
OFS	E.12	-1999	-1999	9999	9999	0	0	Lower range value
dot	E.13	0	0	0.000	3	0	0	Decimal point
En.A	E.14	-19.99	-19.99	99.99	99.99	10.00	10.00	Final value of meas. input
OF.A	E.15	-19.99	-19.99	99.99	99.99	0.00	0.00	Initial value of meas. input
tAr	E.16	-1999	-1999	9999	9999	0	0	Tara value
SP.C	E.20	0	0	9	9	0	0	Supporting points
dl.1	E.21	-199(9)		999(9)				SPx display value
In.1	E.22	-19.9(9)		99.9(9)				SPx analogue value
...	...							
dl.9	E.37	-199(9)		999(9)				SPx display value
In.9	E.38	-19.9(9)		99.9(9)				SPx analogue value
rEt								

End / OFS – E.11 / E.12: Upper range value / Lower range value

This value pair is used to assign the measurement signal to the desired display value.

Dot – E.13: Decimal point

The decimal point defines the decimal representation of the displayed value. This is also used for the setting of the limit value.

En.A / OF.A – E.14 / E.15: Rescaling of measurement input values

With this function, the final value/initial value can be rescaled to e.g. 19,5 mA/3,2 mA, without applying a measuring signal.

tAr – E.16: Setting of tara value / offset value

The preset value is added to the linearized value. This allows the characteristic line to be shifted by the selected amount.

SP.C – E.20: Number of additional supporting points

For initial and final value, it is possible to define 9 additional supporting points, in order to linearize non-linear sensor values. Only activated supporting point parameters are displayed.

dl.1...dl.9 – E.21, E.23, E.25, E.27, E.29. E.31, E.33, E.35. E,37: Display value for supporting points

The supporting points are defined by value under this parameter.

In.1...In.9 – E.22, E.24, E.26, E.28, E.30. E.32, E.34, E.36. E,38: Analogue value for supporting points

The supporting points are always specified according to the selected input signal mA / V. Here, the desired analog values can be freely parameterized.

rEt: Exit submenu.

6.2.2 Temperature measurement**6.2.2.1 Device parameter for the allocation of Pt100(0): Pt.S**

Pt.S: There are three variants available:

Pt.L: Pt100 3-wire -50.0...200.0°C / -58.0...392.0°F

Pt.H: Pt100 3-wire -200...850°C / -328...1562°F

Pt.t: Pt1000 2-wire -200...850°C / -328...1562°F



Parameter	Menu item	Default
Pt.S	PT.S	PT.L

Parameter	Menu item	Default	Description					
UnL	FLt	UnL	FLt					
Unt	E.41	°C	0	°F	1	°C	0	Unit
OFS	E.42	-19.9	-19.9	19.9	19.9	0.0	0.0	Impedance matching
		-35.9	-35.9	35.9	35.9	0.0	0.0	
rEt								

Unt – E.41: Type of temperature measurement
 Select the indication of the temperature in °C oder °F with **Unt**.

OFS – E.42: Impedance matching
 In case of a switchover, the value is rounded.

rEt: Exit submenu.

6.2.2.2 Temperature measurement thermocouple: tHE

tHE: Here a distinction is made between: **Thermocouple types L, J, K, B, S, N, E, T, R**

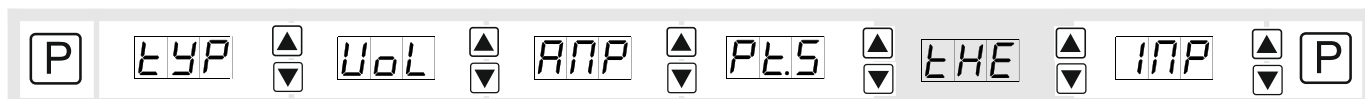

Parameter	Menu item	Default
tHE	tHE	t4.L t4.J t4.H t4.b t4.L
		t4.S t4.n t4.E t4.t
		t4.r

Parameter		Menu item		Default		Default		Description
UnL	FLt	UnL	FLt	UnL	FLt	UnL	FLt	
Unt	E.41	°C	0	°F	1	°C	0	Unit
OFS	E.42	-19.9	-19.9	19.9	19.9	0.0	0.0	Impedance matching
		-35.9	-35.9	35.9	35.9	0.0	0.0	
rEt								

Unt – E.41: Type of temperature measurement
 Select the indication of the temperature in °C oder °F with **Unt**.

OFS – E.42: Impedance matching
 In case of a switchover, the value is rounded.

rEt: Exit sub menu.

6.2.3 Pulse signal: IMP

FrE: Frequency measurement of TTL-signals, PNP-/NPN-sensors.

trn: Rotational speed measurement (simplified adjustment) of TTL-signals, PNP-/NPN-sensors.
 This function also scales a flow.

C.up: Counter input (upwards) for TTL-signals, PNP-/NPN-sensors.

C.dn: Counter input (downwards) for TTL-signals, PNP-/NPN-sensors.

6.2.3.1 Frequency measurement, FrE



Parameter	Menu item	Menu item	Default
IMPu	INP	FrE	

Parameter		Menu item				Default		Description
UnL	FLt	UnL	FLt	UnL	FLt	UnL	FLt	
rnG	E.51	9.99	0	99.9	1	9E3	3	Frequency range
		999	2	9E3	3			
I.tY	E.52	ttL	0	nPn	1	ttL	0	Pulse signal
		PnP	2	nAM	3			
FIL	E.53	no	0	2	1	no	0	Filter frequency
		5	2	10	3			
		20	4	50	5			
		100	6	200	7			
		500	8					
End	E.54	-1999	-1999	9999	9999	1000	1000	Final value
OFS	E.55	-1999	-1999	9999	9999	0	0	Initial value
dot	E.56	0	0	0.000	3	0	0	Decimal point
En.F	E.57	0	0	9999	9999	1000	1000	Final frequency
OF.F	E.58	0	0	9999	9999	0	0	Initial frequency
tAr	E.59	-1999	1999	9999	9999	0	0	Tara value
SP.C	E.60	0	0	9	9	0	0	Supporting points
dl.1	E.61	-1999		9999				SPx display value
In.1	E.62	0		9999				SPx analogue value
...								
dl.9	E.77	-1999		9999				SPx display value
In.9	E.78	0		9999				SPx analogue value
rEt								

rnG – E.51: Selection of the frequency range

Select between 4 different frequency ranges:

- 9.99 – 0: 0...9.999 Hz (automatic software filter at 100 Hz / 5 ms)
- 99.9 – 1: 0...99.99 Hz (automatic software filter at 500 Hz / 5 ms)
- 999 – 2: 0...999.9 Hz
- 9E3 – 3: 0...9999 Hz

I.tY – E.52: Pulse signal

The triggering of the pulse signal can be done in 4 different modes:

- ttL – 0: Active TTL-signals with approx. 0.8 V lower and approx. 2 V upper threshold.
- nPn – 1: Passive switching contact, that switches the internal pullup to earth.
- PnP – 2: Active sensor output. The indicator operates a pullup.
- nAm – 3: Namur input

FIL – E.53: Limitation of the pulse length

Debouncing of mechanical contacts via the choice of filter frequency.

- no – 0: No evaluation of the pulse length.
- 2 – 1: 2 Hz at pulse-duty factor 1:1 => minimum pulse length 250 ms
- 5 – 2: 5 Hz at pulse-duty factor 1:1 => minimum pulse length 100 ms
- 10 – 3: 10 Hz at pulse-duty factor 1:1 => minimum pulse length 50 ms
- 20 – 4: 20 Hz at pulse-duty factor 1:1 => minimum pulse length 25 ms
- 50 – 5: 50 Hz at pulse-duty factor 1:1 => minimum pulse length 10 ms
- 100 – 6: 100 Hz at pulse-duty factor 1:1 => minimum pulse length 5 ms
- 200 – 7: 200 Hz at pulse-duty factor 1:1 => minimum pulse length 2.5 ms
- 500 – 8: 500 Hz at pulse-duty factor 1:1 => minimum pulse length 1 ms

End / OFS – E.54 / E.55: Upper range value / Lower range value

This value pair is used to assign the desired display value to the pulse signal.

dot – E.56: Decimal point

The decimal point defines the decimal representation of the displayed value. This is also used for the setting of the limit value.

En.F / OF.F– E.57 / E.58: Rescaling of pulse signals

tAr – E.59: Setting of tara value / offset value

The preset value is added to the linearized value. This allows the characteristic line to be shifted by the selected amount.

SP.C – E.60: Number of additional supporting points

For initial and final value, it is possible to define 9 additional supporting points, in order to linearize non-linear sensor values. Only activated supporting point parameters are displayed.

dl.1...dl.2 – E.61, E.63, E.65, E.67, E.69, E.71, E.73, E.75, E.77: Display value for supporting points

The supporting points are defined by value under this parameter.

In.1...In.29 – E.62, E.64, E.66, E.68, E.70, E.72, E.74, E.76, E.78: Analoge value for supporting points

The supporting points are always specified according to the selected input signal mA / V. Here, the desired analog values can be freely parameterized.

rEt: Exit submenu.

6.2.3.2 Rotational speed measurement: trn

As more than 80% of the frequency measurement applications refer to one rotational speed, there is a simplified setting option via the **trn** type. This function also scales a flow.

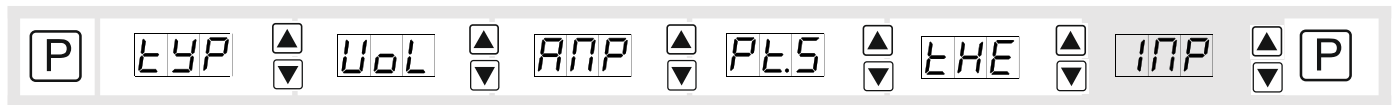

Parameter	Menu item	Default
IMP	INP	trn

Parameter		Menu item				Default		Description
UnL	FLt	UnL	FLt	UnL	FLt	UnL	FLt	
I.tY	E.81	ttL	0	nPn	1	ttL	0	Pulse signal
		PnP	2	nAM	3			
FIL	E.82	no	0	2	1	no	0	Filter frequency
		5	2	10	3			
		20	4	50	5			
		100	6	200	7			
		500	8					
PPt	E.83	1	1	9999	9999	1	1	Pulses per turn
tIM	E.84	SEC	0	MIn	1	MIn	1	Time basis
		hou	2					
dot	E.85	0	0	0.000	3	0	0	Decimal point
rEt								

I.tY – E.81: Pulse signal

The triggering of the pulse signal can be done in 4 different modes:

- ttL – 0: Active TTL-signals with approx. 0.8 V lower and approx. 2 V upper threshold.
- nPn – 1: Passive switching contact, that switches the internal pullup to earth.
- PnP – 2: Active sensor output. The indicator operates a pullup.
- nAm – 3: Namur input

FIL – E.82: Limitation of the pulse length

Debouncing of mechanical contacts via the choice of filter frequency.

- no – 0: No evaluation of the pulse length.
- 2 – 1: 2 Hz at pulse-duty factor 1:1 => minimum pulse length 250 ms
- 5 – 2: 5 Hz at pulse-duty factor 1:1 => minimum pulse length 100 ms
- 10 – 3: 10 Hz at pulse-duty factor 1:1 => minimum pulse length 50 ms
- 20 – 4: 20 Hz at pulse-duty factor 1:1 => minimum pulse length 25 ms
- 50 – 5: 50 Hz at pulse-duty factor 1:1 => minimum pulse length 10 ms
- 100 – 6: 100 Hz at pulse-duty factor 1:1 => minimum pulse length 5 ms
- 200 – 7: 200 Hz at pulse-duty factor 1:1 => minimum pulse length 2.5 ms
- 500 – 8: 500 Hz at pulse-duty factor 1:1 => minimum pulse length 1 ms

Ppt – E.83: Pulses per turn

Via this parameter, the number of pulses per turn can be entered directly. Here, you will usually work with sprockets and their teeth, incremental encoders with their resolution and discs with a number of drilled holes. With simple flow meters with impeller, you only enter the number of pulses per liter or cubic meter.

tIM – E.84: Time basis

The changed time basis for the rotational speed is usually always minute, but can be changed to second and hour.

dot– E.85: Decimal point

The decimal point defines the decimal place of the display value. Thus, a rotational speed can be displayed with up to 3 decimal places, if this is small enough.

ret: Exit submenu.

6.2.3.3 Counter upwards/downwards: C.uP / C.dn

Parameter	Menu item	Default
IMP	C.uP / C.dn	

Parameter	Menu item	Default	Description					
UnL	FLt	UnL	FLt	UnL	FLt	UnL	FLt	
I.tY	E.91	ttL	0	nPn	1	ttL	0	Pulse signal
		Pep	2	nAM	3			
C.bA	E.92	PLS	0	SEC	1	PLS	0	Counter basis
		Min	2					
EdG	E.93	PoS	0	nEG	1	PoS	0	Flank
PrE	E.94	1	1	9999	9999	1	1	Prescaler
FIL	E.95	no	0	2	1	no	1	Filter frequency
		5	2	10	3			
		20	4	50	5			
		100	6	200	7			
		500	8					
End	E.96	-1999	-1999	9999	9999	1000	1000	Final value
En.C	E.97	1	1	9999	9999	1000	1000	Final value pulse number
rSt	E.98	0	0	9999	9999	0	0	Reset value
dot	E.99	0	0	0.000	3	0	0	Decimal point
rEt								

I.tY – E.91: Pulse signal

The triggering of the pulse signal can be done in 4 different modes:

- ttL – 0: Active TTL-signals with approx. 0.8 V lower and approx. 2 V upper threshold.
- nPn – 1: Passive switching contact, that switches the internal pullup to earth.
- PnP – 2: Active sensor output. The indicator operates a pullup.
- nAm – 3: Namur input

C.bA – E.92: Counter basis

By default, the display detects the incoming pulses in counting mode. However, the system time in seconds or minutes can also be used as a counter basis. The pulse input becomes the gate time, which counts at the flank **PoS** (HIGH signal) and is at **LOW**. At the flank **nEG** the logic is reversed.

edG – E.93: Counter start/Counter end (Flank)

The active flank indicates, when is being counted. If the pulse detection **PuL** is selected as counter basis, then it is specified whether the internal counter is increased on the positive flank **PoS** or the negative flank **nEG**. If time is the counter basis, then the active/**HIGH** control is selected with **PoS** and the passive/**LOW** control with **nEG**. The counter reset is always static.

PrE – E.94: Prescaler

A prescaling takes place in the display via the prescaler, so that also large numbers of pulses, e.g. 5.000.000 can be determined by the indicator. Only the prescaled value is included for the scaling.

FIL – E.95: Limitation of the pulse length

Debouncing of mechanical contacts via the choice of filter frequency.

- no – 0: No evaluation of the pulse length.
- 2 – 1: 2 Hz at pulse-duty factor 1:1 => minimum pulse length 250 ms
- 5 – 2: 5 Hz at pulse-duty factor 1:1 => minimum pulse length 100 ms
- 10 – 3: 10 Hz at pulse-duty factor 1:1 => minimum pulse length 50 ms
- 20 – 4: 20 Hz at pulse-duty factor 1:1 => minimum pulse length 25 ms
- 50 – 5: 50 Hz at pulse-duty factor 1:1 => minimum pulse length 10 ms
- 100 – 6: 100 Hz at pulse-duty factor 1:1 => minimum pulse length 5 ms
- 200 – 7: 200 Hz at pulse-duty factor 1:1 => minimum pulse length 2.5 ms
- 500 – 8: 500 Hz at pulse-duty factor 1:1 => minimum pulse length 1 ms

rSt – E.96: Reset value

With the setting **rSt = 0**, the start value is reset by a reset contact. If the value is not equal to zero, the display value is changed by the number of entered pulses. The change takes place in the opposite direction to the preset running direction.

End / En.C – E.97 / E.98: Final display value und final pulse number value

The final display value is freely linearized over the prescaled pulse number. For this purpose, the number of desired pulses is assigned to a display value. The zero point cannot be preselected. For a backward counter, the **end** and **En.C** are used as initial values. For the absolute counter limits the settings of **dl.H** and **dl.L** are used. When these are reached, all digits flash with the reached value, which corresponds to an overflow or underflow.

dot– E.99: Decimal point

The decimal point defines the decimal place of the display value.

ret: Exit submenu.

6.3 General parameters: GEn

Parameter		Menu item				Default		Description
UnL	FLt	UnL	FLt	UnL	FLt	UnL	FLt	
dIS	A.01	Act	0	tot	1	Act	0	Display value
		bUS	2					
di.T	A.02	0.1	0.1	2.0	2.0	1.0	1.0	Display time
SEC	A.03	0.01	0.01	2.00	2.00	1.00	1.00	Measuring time
GLM	A.04	1	1	20	20	1	1	Averaging
ZEr	A.05	0	0	99	99	0	0	Zero point steadying
Arl	A.06	no	0	rot	1	no	0	Arithmetic
		SqU	2	rEP	3			
Ovr	A.07	no	0	AdC	1	no	0	Oberflow/underflow behaviour
		rnG	2	5P	3			
		10P	4					
dI.L	A.08	-1999	-1999	9999	9999	9999	9999	Minimum value
dI.H	A.09	-1999	-1999	9999	9999	-1999	-1999	Maximum value
brt	A.10	1	1	9	9	6	6	Brightness
tSt	A.11	no	0	Ext	1	no	0	Key function
		A.LI	2	tAr	3			
		to.r	4	Ac.A	5			
dI.F	A.12	no	0	Ac.A	1	No	0	Digital input
		tr.A	2	tAr	3			
		to.r	4	Ac.A	5			
rEt								

dIS – A.01: Display value

Choose between the current measured value, the totalizer value and the ModBus.

- Act – 0: Current measurand
- tot – 1: Totalizer
- bUS – 2: ModBus

di.t – A.02: Display time

Via this function, the displayed value can be steadied. Alarms and analogue output are still controlled by the measuring time.

SEC – A.03: Measuring time

Set the basic measuring time or the frequency filter to steady the measured value. This filter value is adjustable from 0.01 ... 2.00 seconds. For pulse measurements, the value can be set up to 0.00, so detection runs at maximum speed.

GLM – A.04: Averaging

In addition to the measuring time, a moving averaging of 1 ... 20 values can be activated, too. There is no separate weighting between the past values. If **GLM = 1** is set, the moving averaging is switched off.

ZEr – A.05: Zero point steadying

For zero point steadying, a value range around the zero point can be preselected, at which the display represents a zero. If e.g. 10 is set, the display will display zero in a range of +10 to -10 and below, it will continue down with -11 and above with +11.

Ari – A.06: Arithmetic

This function does not display the measured value but the calculated value in the display:

- no – 0: No calculation
- rot – 1: Root
- SqU – 2: Square root
- rEP – 3: Reciprocal value

Calculation types

rep = Final value/Display value

rot = $\text{Root}(\text{Display value} \cdot \text{Final value})$

SqU = $(\text{Display value})^2 / \text{Final value}$

Advice: The denominator of fractions should not be 0 because a division by 0 is not possible. It creates an undefined state and the display goes into the overflow.

Ovr – A.07: Overflow/Underflow behaviour

The overflow/underflow of the measuring input is indicated by 3 bars at the top or 3 bars at the bottom. The exception is input type **4-20 mA**, here a measured value smaller than 1 mA is already considered as underflow. This shall indicate a sensor failure.

- no – 0: No overflow evaluation
- AdC – 1: Depends on **dl.L** and **dl.H**
- rAG – 2: Depends on **OFS** and **End**
- 5P – 3: $\pm 5\%$ of **OFS** and **End**
- 10P – 4: $\pm 10\%$ of **OFS** and **End**

dl.L / dl.H – A.08 / A.09: Indication of initial value and final value in the display

For overflow evaluation, the measuring range and the optionally selected overflow behavior **Ovr** are evaluated. In addition, this range can be further limited by these two parameters.

brt – A.10: Brightness

Here, the brightness of the display can be adjusted in 9 levels.

tSt – A.11: Allocation of key functions

Here, either a minimum/maximum value query or a limit value correction can be stored on the navigation keys for the operating mode. If the minimum/maximum memory is activated with **EXt**, the measured minimum/maximum values are stored during operation and can be queried via the navigation keys [**▲**] [**▼**]. When the device is restarted, the values are lost. If the limit value correction **A.LI** is selected, it is possible to change the values of the threshold values during operation without hindering the operating mode. With **tA.r** the display is tared to zero and saved permanently as Offset. If **to.r** was desposited, the totalizer can be set back by pressing the navigation keys [**▲**] [**▼**], the display acknowledges this by showing **000**. The alarm acknowledgement is set via **Ac.A** for each alarm. If an alarm occurs, the alarm indication can be set back via the navigation keys [**▲**] [**▼**], or optional via the digital input. It does not matter, if the the alarm condition is still achieved. If **no** was adjusted, then the navigation keys [**▲**] [**▼**] are without functions in operating mode.

- no – 0: No function
- EXt – 1: Display minimum/maximum-value
- A.LI – 2: Show/change alarm limit
- tA.r – 3: Taring
- to.r – 4: Totalizer reset
- Ac.A – 5: Acknowledge alarm

dl.F – A.12: Function of digital input

- no – 0: No function
- Ac.A – 1: Acknowledge alarm
- tr.A – 2: Trigger alarm (the alarm is activated via the digital input, not via the display value)
- tAr – 3: Taring
- to.r – 4: Totalizer reset
- AAL – 5: Alternative threshold value, needs to be activated under **x.Fu (threshold value behaviour)**

ret: Exit submenu.

6.4 Analog output parameters: Out

Parameter		Menu item				Default		Description
UnL	FLt	UnL	FLt	UnL	FLt	UnL	FLt	
A.In	o.01	Act	0	Min	1	Act	0	Reference source
		MAX	2		3			
A.rA	o.02	0.10	0	0.20	1	0.10		Output signal
		4.20	2					
A.En	o.03	-1999	-1999	9999	9999	1000		Final value
A.OF	o.04	-1999	-1999	9999	9999	0		Initial value
A.FL	o.05	EdG	2	t.En	1	EdG		Underflow/overflow behaviour
		t.OF	4	t.Mi	3			
		t.MA	6					
Ret								

A.In – o.01: Reference of the analogue output

The analog output signal may refer to various functions.

- Act – 0: Current measurand
- MIn – 1: Minimum value
- MAX – 2: Maximum value

A.rA – o.02: Output signal

- 0.10 – 0: 0...10 V
- 0.20 – 1: 0...20 mA
- 4.20 – 2: 4...20 mA

A.En – o.03: Final value of analogue output

A.OF – o.04: Initial value of analogue output

A.FL – o.05: Overflow behaviour

To detect and evaluate faulty signals, e.g. via a controller, the overflow behavior of the analogue output can be defined.

- EdG – 0 : The analogue output runs to the set limit, e.g. 4 and 20 mA.
- t.En – 1: The analogue output jumps to the final value e.g. 20 mA.
- t.OF – 2: The analogue output jumps to the initial value e.g. 4 mA.
- t.MI – 3: The analogue output jumps to the smallest possible output value.
- t.MA – 4: The analogue output jumps to the highest possible output value. The value can be higher than 20 mA or 1V, too.

ret: Exit submenu.

6.5 Interface parameters: Ser

The interface data for a communication via RS232, RS485 and Bluetooth correspond to:

- 9600 Baud
- 8 Data bits
- 1 Stop bit
- No parity

Parameter		Menu item				Default		Description
UnL	FLt	UnL	FLt	UnL	FLt	UnL	FLt	
Adr	r.01	1	1	250	250	1	1	Address
Mod	r.02	ASC	0	Rtu	1	ASC	0	Modus
t.Ou	r.03	0	0	100	100	0	0	Timeout
Pin	r.04	0000	0000	9999	9999	0	0000	Pin number
Ret								

Adr: Modbus address

Device address under which the device can be reached in the communication bus.

Mod: Modbus mode

- ASC – 0: ASCII mode. A communication with the PM-TOOL is only possible in this mode.
- rtu – 1: Remote Terminal Unit. Here, the data are transmitted in binary form.

t.ou: Modbus timeout

If a value greater than 0 is set, an internal timer is reset to the adjusted value for each communication. If the timer runs to zero, a timeout error is generated. This leads to an error bit, which can be output via a register or forwarded to an alarm.

Pin: Safety code for Bluetooth

This code is required for communication with the PM-TOOL. This code can be used to deny access to the data. If the value is 0, the data can be queried without a pin.

ret: Exit submenu.

6.6 Data logger (in preparation)

6.7 Alarm parameters, AL:

Parameter		Menu item				Default		Description
UnL	FLt	UnL	FLt	UnL	FLt	UnL	FLt	
x.Sr	x.00	OFF	0	A.In	1	OFF	0	Alarm source
		tot	2	d.In	3			
		bUS	4	S.Er	5			
x.Fu	x.01	H.LI	0	L.LI	1	H.LI	0	Threshold value behaviour
		H.LA	2	L.LA	3			
		rnG	4	OU.r	5			
x.bH	x.02	on	0	OFF	1	on	0	Behaviour system error / digital input
x.rE	x.03	no	0	rE.1	1	no	0	Alarm output
		rE.2	2	PH.1	3			
		PH.2	4					
x.LI	x.04	-1999	-1999	9999	9999	100	100	Limit
x.HY	x.05	0	0	9999	9999	0	0	Hysteresis
x.HI	x.06	-1999	-1999	9999	9999	200	200	Upper window limit
x.Lo	x.07	-1999	-1999	9999	9999	100	100	Lower window limit
x.oF	x.08	0	0	100	100	0	0	Switching off delay
x.on	x.09	0	0	100	100	0	0	Switch-on delay
x.FL	x.10	on	0	OFF	1	OFF	1	Alarm flashing
x.Ac	x.11	on	0	OFF	1	OFF	1	Alarm acknowledgement
x.AL	x.12	-1999	-1999	9999	9999	15	200	Alternative threshold value
ret								

x.Sr – x.00: Alarm source

- OFF – 0: Deactive
- A.In – 1: Measuring signal
- tot – 2: Totalizer value
- d.In – 3: Digital input
- bUS – 4: Modbus
- S.Er – 5: System error

System errors can be triggered by overflow, underflow and ModBus timeout.

x.Fu – x.01: Threshold value behaviour

With the functional principle it is possible to switch between different work types of the switching outputs:

- H.LI – 0: Switch at threshold value exceedance.
- L.LI – 1: Switch at threshold value undercut.
- H.LA – 2: Exceeding the alternative threshold value, is triggered by the digital input.
- L.LA – 3: Falling below the alternative threshold value, is triggered by the digital input.
- rnG – 4: Switch within the preset range.
- Ou.r – 5: Switch outside the preset range.

x.bH – x.02: Alarm at system error / digital input

If a device checksum is not correct or the display range is violated, you can preset the behavior of the switching points.

- on – 0: Alarm is activated in case of an error / digital input (relay switched off).
- OFF – 1: Alarm is activated in case of no error / digital input (relay switched).

x.rE – x.03: Alarm output

- no – 0: No output selection
- rE.1 – 1: Relay 1
- rE.2 – 2: Relay 2
- Ph.1 – 3: PhotoMos output 1
- Ph.2 – 4: PhotoMos output 2

x.LI – x.04: Switching threshold

Here, the switching threshold is specified, from which an alarm responds or is activated / deactivated. For the window function of a switching point, this parameter is not requested.

x.HY – x.05: Hysteresis

The hysteresis defines a difference to the threshold value by which an alarm reacts delayed. This parameter is not queried in the window function of a switching point.

x.HI / x.Lo – x.06 / x.07: Upper and lower threshold value at window function

For the range functions **x.Fu = rAG** or **Ou.r**, this value defines the upper / lower limit of the window function between -199(9)...999(9). Other operating principles do not display this parameter. The operating principle can change between switching point 1 and 2.

x.oF – x.08: Delayed release

Here, a delayed switch-off of 0-100s can be preset for the threshold values. The time value is not stored permanently and is reset by a device startup.

x.on – x.09: On-delay

Here, a delayed switch-on of 0-100s can be preset for the threshold values. The time value is not stored permanently and is reset by a device startup.

x.FL – x.10: Alarm flashing

Flashing of the display in case of an alarm violation.

x.Ac – x.11: Alarm acknowledgement

The alarm can not reset itself. An acknowledgement via the digital input is necessary.

x.AL – x.12: Alternative threshold value

By use of this function, an additional threshold value can be parameterized and activated via the digital input. The behavior of the threshold value needs to be preset under **x.Fu**.

ret: Exit submenu.

6.8 Totalizer, tot:

Parameter		Menu item				Default		Description
UnL	FLt	UnL	FLt	UnL	FLt	UnL	FLt	
t.FC	t.01	OFF	0	Std	1	OFF	0	Totalizer state
		tMP	2					
t.bA	t.02	SEC	0	Min	1	SEC	0	Time basis
		Hou	2					
t.FA	t.03	E^0	0	E^1	1	E^0	0	Factor
		E^2	2	E^3	3			
		E^4	4	E^5	5			
		E^6	6					
t.Dt	t.04	000	0	00.0	1	0	0	Dezimal place
		0.00	2	0.000	3			
t.rE	t.05	-1999	-1999	9999	9999	0	0	Reset value
ret								

t.FC – t.01: Totalizer state

- **OFF – 0**: Deactivated
- **Std – 1**: The scaled input value is integrated over a period of time and stored permanently.
- **tMP – 2**: The scaled input value is integrated over time and stored volatile.

t.bA – t.02: Time basis

- **SEC – 0**: Seconds
- **Min – 1**: Minutes
- **Hou – 2**: Hours

t.FA – t.03: Totalizer factor

Here, the factor or divisor for the internal calculation of the measurand is assigned.

- E⁰ – 0: 10⁰
- E¹ – 1: 10¹
- E² – 2: 10²
- E³ – 3: 10³
- E⁴ – 4: 10⁴
- E⁵ – 5: 10⁵
- E⁶ – 6: 10⁶

t.dt – t.04: Decimal place

Decimal place for the totalizer.

t.rE – t.05: Totalizer reset value

ret: Exit submenu.

6.9 Safety parameters, SEc:

Parameter		Menu item		Default		Description		
UnL	FLt	UnL	FLt	UnL	FLt	UnL	FLt	
U.Co	C.01	0000	0000	9999	9999	0	0	User code
A.Co	C.02	0000	0000	9999	9999	0	0	Admin code
LEV	C.03	0	0	8	8	6	6	User level
U:AC	C.04	UnL	0	LOC	1	UnL	0	Exit parameterization
A.AC	C.05	0	0	9999	9999			Unlock administrator menu
LFS	C.06	no	0	YES	1	no	0	Load factory settings
ret								

U.Co – C.01: User code

With this code, limited access to the parameters is possible, depending on the set user level. The user only sees the released menu items.

A.Co – C.02: Admin code

Assignment of an individual numerical code (4-digit number combination, freely assignable). If this code is assigned (0000 factory setting), all parameters are locked to the user, when **LOC** is subsequently selected in the menu item **RUN**. By pressing **[P]** in operating mode for approx. 3 seconds, the display will show the message **Cod**. The code must be entered before each attempted parameterization.

LEV – C.03: Defines the parameters, which are accessible to the user.:

User level =		0	1	2	3	4	5	6
Access to menu	Description							
Alarm x	Threshold value	X	X	X	X	X	X	X
Alarm x	Hysteresis/Threshold value	X	X	X	X	X	X	
Alarm x	all parameters	X	X	X	X	X		
Measuring input		X	X	X				
Analogue output		X	X	X				
General		X	X	X				
Data logger		X	X	X				
Interface		X	X	X				
Totalizer		X	X	X				

U.AC – C.04: Activation / Deactivation of programming interlock

Here, select between deactivated key lock **UnL** (factory setting) and activated key lock **LOC** with **[▲]** **[▼]**. If **LOC** is selected, the keyboard is locked. In order to return to the menu level, **[P]** must be pressed for 3 seconds in operating mode. The now appearing code (factory setting 0000) is entered with **[▲]** **[▼]** and **[P]** and unlocks the keyboard. An incorrect entry is displayed with **FAL**. In the **LOC** mode, the display can not be reset, which should additionally ensure regular operation.

- UnL – 0: All parameters are open.
- LOC – 1: Parameterization is locked.

A.AC – C.05: Unlock administrator menu

LFS – C.06: Load factory settings

- no – 0: Break-off of the function, settings are not overwritten.
- YES – 1: Loading the factory settings. **Attention! All settings in the device will be overwritten!**

7. Modbus protocol

The display value sent via Modbus can be steadied by moving averaging. The display always communicates via the Modbus protocol with the PC. This is independent of the fact whether an RS232/RS485 interface is available or not. For displays without RS232/RS485 interface, the transmission is carried out via the configuration interface.

The byte protocol is determined to:

1 start bit, 8 data bits, 1 stop bit, no parity with a fix Baud rate of 9600 Baud.

For devices without an RS232-/RS485-interfaces, there is no direct access to the parameters for the Modbus, in this case, only the use of the USB interface for configuration via the PM-TOOL is provided. These parameters can also be adjusted via the bus.

Compatibility – The interface is compatible to the MODBUS protocol from „Modicon“. This means, that all register have a size of 16-bit. Bigger data types are realised by laying several register one after another. A non Modicon-compatible mode is supported, too. In this mode, each data type occupies only one register that corresponds to the size of the data type (minimum is always 16-bit).

Advice: Access to data types that occupy multiple registers must always be done in a reading / writing access and must not be distributed to multiple reading / writing accesses!

Device address - As device address, a value between 1 and 247 can be used. At address 0, you can reach several devices simultaneously (broadcast), if the corresponding function is supported.

Transfer mode - The devices support the RTU mode (binary data) and ASCII mode (alphanumeric characters - hexadecimal, default). The RTU mode is faster because fewer bytes need to be transmitted, but more time-critical. ASCII mode is better at communicating with PC-based systems, as they often cannot fulfill the time-critical conditions for RTU mode.

Attention: If the mode is set to RTU, communication with the PM-Tool is no longer possible. This can only be used in ASCII mode.

Name	Value range	Memory size	Number of register in Modicon-compatible Bus	Number of register in non-Modicon-compatible Bus
INT08	-128...127	2 Byte	1	1
UINT08	0...255	2 Byte	1	1
INT16	-32768...32767	2 Byte	1	1
UINT16	0...65535	2 Byte	1	1
INT32	-2147843648... 2147843674	4 Byte	2	1
UINT32	0...4294967295	4 Byte	2	1
INT64	-9223372036854775808 ...9,22337E-/ +38	8 Byte	4	1
FLOAT	-/+3.402823466 e-/ +38	4 Byte	2	1

Modbus-ASCII

Start	Device address	Function	Data	CRC-value	End
Signs " : "	2 signs	2 signs	nx2 signs	2 signs	2 signs "/r/n"

Modbus-RTU (Holding time > 4 ms between the frames)

Device address	Function	Data	CRC value
1 Byte	1 Byte	n Bytes	2 Bytes

Supported function codes

Code	Function	Description
0x03	READ HOLDING REGISTER	e.g. measuring values and alarm status
0x04	READ INPUT REGISTER	same function as code 0x03
0x08	DIGANOSTIC	Device diagnostic
0x10	WRITE MULTIPLE REGISTER	e.g. transfer of measuring values and alarm status to the indicator

Modbus index

Name	Index	Access mode	Min/Max-value data type	Comment	
Device number	0x4400 /17408	read/ write	0...65535 UINT16	Identification defined by user	
Relay 1 active	0x4500 /17664	read	0/1 UINT16	Value	Function
				0	Inactive
				1	Active
Relay 2 active	0x4501 /17665	read	0/1 UINT16	Value	Function
				0	Inactive
				1	Active
Relay 3 active	0x4502 /17666	read	0/1 UINT16	Value	Function
				0	Inactive
				1	Active

Name	Index	Access mode	Min/Max-value data type	Comment	
Relay 4 active	0x4503 /17667	read	0/1 UINT16	Value	Function
				0	Inactive
				1	Active
Digital input	0x4510 /17680	write	0/1 UINT16	Value	Function
				0	Inactive
				1	Active
Alarm status	0x4520 /17696	read/ write	UINT16	Bit0...Bit7 equates alarm 1...8 (write: only, if the specified alarm is set to bUS)	
Measurand LOW-WORD	0x6000 /24576	read/ write	-1999...9999 INT32	Enter measurand (write: only at dIS=bUS)	
Measurand HIGH-WORD	0x6001 /24577				
Decimal point	0x6002 /24578	read/ write	0...3 UINT16	Value	Function
				0	0
				1	0.0
				2	0.00
Totalizer LOW-WORD	0x6004 /24580	read	UINT16	Current totalizer value	
				Totalizer HIGH-WORD	0x6005 /24581
Totalizer decimal point	0x6006 /24582	read	0...3 UINT16	Value	Function
				0	0
				1	0.0
				2	0.00
				3	0.000

Name	Index	Access mode	Min/Max-value data type	Bemerkung
Binary value LOW-WORD	0x6100 /24832	read	UINT32	Internal measurand
Binary value HIGH-WORD	0x6101 /24833			
Alarm limit 1	0x6500 /25856	read/ write	-1999...9999 INT16	
Alarm limit 2	0x6501 /25857	read/ write	-1999...9999 INT16	
Alarm limit 3	0x6502 /25858	read/ write	-1999...9999 INT16	
Alarm limit 4	0x6503 /25859	read/ write	-1999...9999 INT16	
Alarm limit 5	0x6504 /25860	read/ write	-1999...9999 INT16	
Alarm limit 6	0x6505 /25861	read/ write	-1999...9999 INT16	
Alarm limit 7	0x6506 /25862	read/ write	-1999...9999 INT16	
Alarm limit 8	0x6507 /25863	read/ write	-1999...9999 INT16	
Alarm limit 1 alternative	0x6510 /25872	read/ write	-1999...9999 INT16	
Alarm limit 2 alternative	0x6511 /25873	read/ write	-1999...9999 INT16	
Alarm limit 3 alternative	0x6512 /25874	read/ write	-1999...9999 INT16	

Name	Index	Access mode	Min/Max-value data type	Comment
Alarm limit 4 alternative	0x6513 /25875	read/ write	-1999...9999 INT16	
Alarm limit 5 alternative	0x6514 /25876	read/ write	-1999...9999 INT16	
Alarm limit 6 alternative	0x6515 /25877	read/ write	-1999...9999 INT16	
Alarm limit 7 alternative	0x6516 /25878	read/ write	-1999...9999 INT16	
Alarm limit 8 alternative	0x6517 /25879	read/ write	-1999...9999 INT16	
Measurand LOW-WORD	0x7000 /28672	read/ write	-20000... 100000	Current scaled measurand (write: only at dIS=bUS)
Measurand HIGH-WORD	0x7001 /28673		FLOAT	
Totalizer LOW-WORD	0x7003 /28674	read	FLOAT	Current totalizer value
Totalizer HIGH-WORD	0x7004 /28675			

Measured value and binary value are designed as 32-bit value and must be transmitted as word in 2x 16-bit parts. The byte sequence within the word is first HIGH-byte and then LOW-byte.

Dis = bUS must be set, so the display value can be written via Modbus.

For direct control of the alarms via the bus, the respective **Ax-function** must be set to **bUS**. Each alarm status can be changed or read out via the corresponding bit. Bit 0 corresponds to alarm 1 ... bit 7 corresponds to alarm 8.

Advice:

When reading the process values as a float, the decimal point that is configured in the device is used. The decimal point that is parameterized in the device is also returned when reading the decimal point.

For indication on the display and for converting the sent float value, too. All parameters changed via Modbus are not stored permanently.

After a restart these values are lost.

8. Reset to default values

There are two ways to reset to the default values:

1.) Voltage supply.

Hold down the **[P]-key** when power is applied until **rES** appears in the display.

2.) Voltage supply cannot be switched off.

Change with the **[P]-key** into menu level.

Then select **LFS** in the **SEC** menu (security parameters) and confirm with **YES** (loading the factory settings).

Attention!

With a reset, all user settings are lost.

9. Technical data

Housing			
Dimensions	22.5 x 117.2 x 107 mm (BxHxD)		
Fixing	Top hat rail		
Housing material	PA6.6, black, UL94V-0		
Connection	Plug-in terminal; wire cross section up to 1.5 mm ²		
Display			
Display	3-digit		
Digit height	7 mm		
Segment colour	Red		
Display range	-199 to 999 (intern -1999 to 9999)		
Switching points	LED S1, LED S2, LED S3, LED S4		
Overflow	Horizontal bars at the top		
Underflow	Horizontal bars at the bottom		
Display time	0.1 to 10.0 seconds		
Measuring input			
Signal	Measuring range	Measuring span	Resolution
Voltage	0...10 V (Ri > 100 kOhm)	0...12 V	≥ 14 bit
Voltage	0...2 V (Ri ≥ 10 kOhm)	0...2,2 V	≥ 14 bit
Voltage	0...1 V (Ri ≥ 10 kOhm)	0...1,1 V	≥ 14 bit
Voltage	0...50 mV (Ri ≥ 10 kOhm)	0...75 mV	
Current	4...20 mA (Ri = ~ 125 Ohm)	1...22 mA	
Current	0...20 mA (Ri = ~ 125 Ohm)	0...22 mA	
Pt100-3-wire	-50...200°C	-58...392°F	0,1°C / 0,1°F
Pt100-3-wire	-200...850°C	-328...1562°F	1°C / 1°F
Pt1000-2-wire	-200...850°C	-328...1562°F	1°C / 1°F
Thermo K	-270...1350°C	-454...2462°F	1°C / 1°F
Thermo S	-50...1750°C	-328...3182°F	1°C / 1°F
Thermo N	-270...1300°C	-454...2372°F	1°C / 1°F
Thermo J	-170...950°C	-274...1742°F	1°C / 1°F
Thermo T	-270...400°C	-454...752°F	1°C / 1°F
Thermo R	-50...1768°C	-58...3214°F	1°C / 1°F
Thermo B	80...1820°C	176...3308°F	1°C / 1°F
Thermo E	-270...100°C	-454...1832°F	1°C / 1°F

Signal	Measuring range	Measuring span	Resolution
Thermo L	-200...900°C	-328...1652°F	1°C / 1°F
Frequency	0...10 kHz	0...10 kHz	0.001 Hz
NPN	0...3 kHz	0...3 kHz	0.001 Hz
PNP	0...1 kHz	0...1 kHz	0.001 Hz
Rotational speed	0...9999 1/min	0...9999 1/min	0.001 1/min
Counter	0...9999 (prescaler up to 1000)		
Pulse input	TTL / Low < 2 V / High > 3 V NPN / Low < 0.8 V / High via resistance	HTL/PNP / Low < 6 V / High > 8 V Namur / Low < 1.5mA/ High > 2.5mA	
Reset input	active < 0.8 V		
Measuring error			
Standard	0.2% of measuring range, ± 1 digit		
Pt100 / Pt1000	0.5% of measuring range, ± 1 digit		
Thermocouple	0.3% of measuring range, ± 1 digit		
Accuracy			
Reference junction	± 1°C		
Temperature drift	100 ppm / K		
Measuring time	0.01...2.0 seconds		
Measuring rate	approx. 1/s with temperature sensor, approx. 100/s with standard signals		
Measuring principle	U/F-conversion		
Resolution	approx. 14 bit at 1 second measuring time		
Output			
Sensor supply	24 VDC / 50 mA incl. digital input, < 2.4V OFF, > 10V ON, max. 30 VDC / Ri~ 14 kOhm		
Switching points			
2x relay outputs with normally open contacts	Switching voltage 30 VDC/AC, max. 2 A resistive load Operating life < 30 mV/< 10 mA – min. 2.5x10 ⁶ 30 VDC / 1 A – min. 5x10 ⁵ 30 VDC / 2 A – min. 1x10 ⁵		
2 PhotoMos outputs with normally open contacts	Switching voltage 30 VDC/AC, max. 0.4 A		
Analog output	0-10 VDC/load min. 10 kOhm, 0/4-20 mA/load max. 500 Ohm, 12 bit		

Interface	Modbus with ASCII or RTU protocol
USB	11520 Baud, no parity, 8 data bit, 1 stopp bit, flow control (none)
Bluetooth	9600 Baud, no parity, 8 data bit, 1 stopp bit, flow control (none)
RS232	9600 Baud, no parity, 8 data bit, 1 stopp bit, wire length maximum 3 m
RS485	9600 Baud, no parity, 8 data bit, 1 stopp bit, wire length maximum 1000 m
Power pack	
Supply	24 VDC \pm 10% galvanic isolated, \leq 5 VA
Supply	100-240 VAC 50/60 Hz DC \pm 10%, \leq 15 VA
Supply	15-40 VDC galvanic isolated / 20-30 VAC 50/60 Hz, \leq 10 VA
Memory	
	EEPROM
Data life	\geq 100 years at 25°C
Ambient conditions	
Working temperature	0°C...50°C
Storing temperature	-20°C...80°C
Weathering resistance	relative humidity 0-85% on years average without dew
EMV	
	EN 61326
CE confomity mark	
	Conformity according to directive 2014/30/EU
Safety regulations	
	According to low voltage directive 2014/35/EU EN 61010; EN 60664-1

10. Safety instructions

Please read the following safety advices and the assembly chapter 2 before installation and keep it for future reference.

Proper use

The **IMH-1U**-device is designed for the evaluation and display of sensor signals.



Danger! Careless use or improper operation can result in personal injury and/or damage the equipment.

Control of the device

The panel meters are checked before dispatch and sent out in perfect condition. Should there be any visible damage, we recommend close examination of the packaging. Please inform the supplier immediately of any damage.

Installation

The **IMH-1U**-device must be installed by a suitably qualified specialist (e.g. with a qualification in industrial electronics).

Notes on installation

- There must be no magnetic or electric fields in the vicinity of the device, e.g. due to transformers, mobile phones or electrostatic discharge.
- **The fuse rating of the supply voltage should not exceed a value of 1A N.B. fuse!**
- Do not install **inductive consumers** (relays, solenoid valves etc.) near the device and **suppress** any interference with the aid of RC spark extinguishing combinations or free-wheeling diodes.
- Keep input, output and supply lines separate from each other and do not lay them parallel with each other. Position “go” and “return lines” next to one another. Where possible use twisted pair. So, the best measuring results can be received.
- Screen off and twist sensor lines. Do not lay current-carrying lines in the vicinity. Connect the **screening on one side** on a suitable potential equaliser (normally signal ground).
- The device is not suitable for installation in areas where there is a risk of explosion.
- Any electrical connection deviating from the connection diagram can endanger human life and/or can destroy the equipment.
- The terminal area of the devices is part of the service. Here electrostatic discharge needs to be avoided. Attention! High voltages can cause dangerous body currents.
- Galvanically isolated potentials within one complex need to be placed on an appropriate point (normally earth or machines ground). So, a lower disturbance sensibility against impacted energy can be reached and dangerous potentials, that can occur on long lines or due to faulty wiring, can be avoided.

11. Error elimination

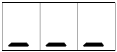
	Error description	Measures
1.	<p>The unit permanently indicates overflow.</p> 	<ul style="list-style-type: none"> The input has a very high measurement, check the measuring circuit. For a selected input with a small sensor signal, it is only connected on one side or the input is open. Not all activated supporting points are parameterized. Check whether the relevant parameters for this are set correctly.
2.	<p>The unit permanently shows underflow.</p> 	<ul style="list-style-type: none"> The input has a very low measurement, check the measuring circuit. For a selected input with a small sensor signal, it is only connected on one side or the input is open. Not all activated supporting points are parameterized. Check whether the relevant parameters for this are set correctly.
3.	<p>The device shows HLP in the 7-segment display.</p>	<ul style="list-style-type: none"> The device has detected an error in the configuration memory, perform a reset to the default values and reconfigure the device according to your application.
4.	<p>Program numbers for the parameterization of the input are not available.</p>	<ul style="list-style-type: none"> The programming lock is activated. Enter correct code.
5.	<p>The device shows Er1 in the 7-segment display.</p>	<ul style="list-style-type: none"> If errors of this kind occur, please contact the manufacturer.
6.	<p>The device does not react as expected.</p>	<ul style="list-style-type: none"> If you are not sure, that the device has already been parameterized before, then restore the delivery state as described in chapter 6.
7.	<p>The device shows Lbr in the 7-segment display.</p>	<ul style="list-style-type: none"> For a selected input with a small sensor signal, it is only connected on one side or the input is open. Only with for measuring input 4-20 mA, thermocouple, PT100(0) sensor.