



IPR20

Datasheet Pressure Switch IPR20

PERFORMANCE FEATURES

- Dry front flush ceramic sensor
- Simple on-site operation via DIP Switch
- Dry ceramic sensor
- Smallest measuring range: 0...500 mbar
- Largest measuring range: 0...50 bar
- Negative pressure measuring range: up to -1 bar
- Accuracy $\leq 0,5\%$
- Compact design
- Analog output: 4...20 mA, 3-wires
- Contact output: DC PNP, max. 200 mA

The IPR20 model is designed for use in applications where media tend to deposit and clog the sensor. A compact front-flush process connection prevents hidden edges and drill holes, in combination with a resistant ceramic sensor, optimal cleaning and maintenance can be ensured. The electrical connection is provided via an integrated clamping strip, while the PG11 cable gland offers IP 67 dust and water protection. Its compact housing is made of high-quality stainless steel 1.4404 and is therefore suitable for almost all media. Our modular design concept provides a wide variety of products. Feel free to contact us if you need a customiza-tion that is not listed in this Datasheet.

AREAS OF APPLICATION

- Gaseous media
- Liquid media
- Abrasive media
- Aggressive media
- Vacuum applications

TECHNICAL DATA

Measuring range:	
Pressure range	See table "Measuring ranges" others on request
Output	
Analog output	4...20 mA 3-wires
Contact output	DC PNP, max. 200 mA
Power supply	
20 mA output	19...30 V DC
Signal characteristics	
Accuracy	$\leq \pm 0,5 \% \text{ FS @ } 25^\circ\text{C}$
Long term stability	$\leq \pm 0,5 \% \text{ FS/Year}$
Response time	50 ms - others on request
Swich-on time	< 1 s
Temperature coefficient	
Zero	$\leq \pm 0,03 \% \text{ FS/Kelvin}$
Span	$\leq \pm 0,02 \% \text{ FS/Kelvin}$
Temperature ranges	
Medium temperature	-25...100 °C
Surrounding temperature	-25...85 °C
Storage temperature	-40...85 °C
Electrical protections	
Short-circuit resistance	Permanent
Reverse polarity protection	Protection against reverse polarity, but no function
Electromagnetic compatibility	Interference emissions and immunity acc. to EN 61326
Wetted materials	
Process connection	Stainless steel 1.4404
Sensor	Ceramic Al_2O_3
Sensor seal	FPM (Viton), NBR, EPDM, FKKM (Chemraz / Kalrez)
Surroundings	
Protection type	IP 67
Electrical connection	
Type	Cable gland M16x1,5 Connector M12x1, 4-pole
Exemplary weight	
IPR20-3D9-G11A-0 (figure p. 1)	Approx. 150 g

ELECTRICAL CONNECTION

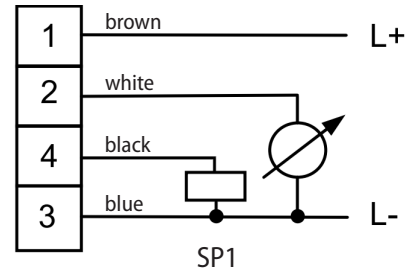

SETTINGS

nc = normally closed
no = normally open

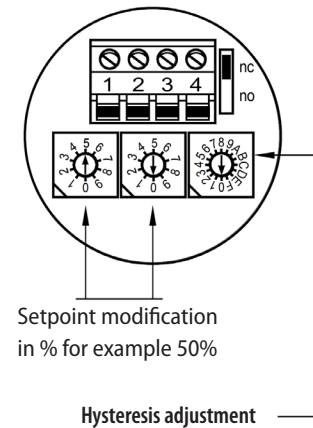

max. Function	min. Function
0 = 0,5 %	8 = 0,5 %
1 = 1 %	9 = 1 %
2 = 2 %	A = 2 %
3 = 3 %	B = 3 %
4 = 4 %	C = 4 %
5 = 6 %	D = 6 %
6 = 8 %	E = 8 %
7 = 10 %	F = 10 %

LOAD

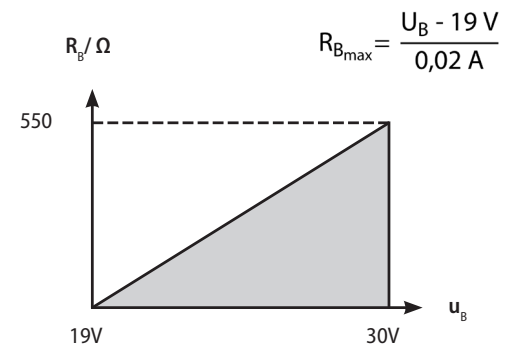

MEASURING RANGES

Measuring ranges	Relative	Overload (bar)
0...500 mbar / 0...50 kPa *	B7	-0,2/2
0...600 mbar / 0...60 kPa	04	-0,2/2
0...1 bar / 0...100 kPa	05	-0,4/4
0...1,6 bar / 0...160 kPa	06	-0,4/4
0...2 bar / 0...200 kPa	B3	-0,4/4
0...2,5 bar / 0...250 kPa	07	-0,8/10
0...4 bar / 0...400 kPa	08	-0,8/10
0...5 bar / 0...500 kPa	F1	-0,8/10
0...6 bar / 0...600 kPa	09	-1/20
0...10 bar / 0...1 MPa	10	-1/40
0...16 bar / 0...1,6 MPa	11	-1/40
0...20 bar / 0...2 MPa	B5	-1/40
0...25 bar / 0...2,5 MPa	12	-1/100
0...50 bar / 0...5 MPa	F3	-1/100
-1...5 bar / -100...500 kPa	D9	-1/20
-1...9 bar / -100...900 kPa	E1	-1/40
-1...15 bar / -100...1500 kPa	E2	-1/40
-1...19 bar / -100...190 kPa	E3	-1/40
-1...25 bar / -100...2500 kPa	E7	-1/40

* Accuracy 1%

DIMENSIONS

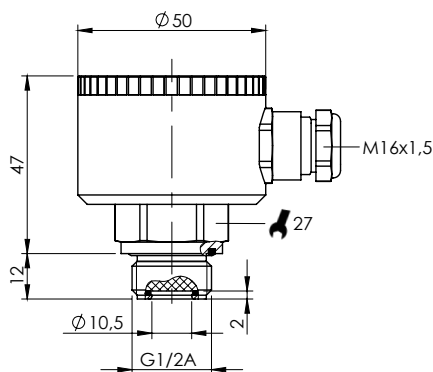

EL. CONNECTION

TYPE G

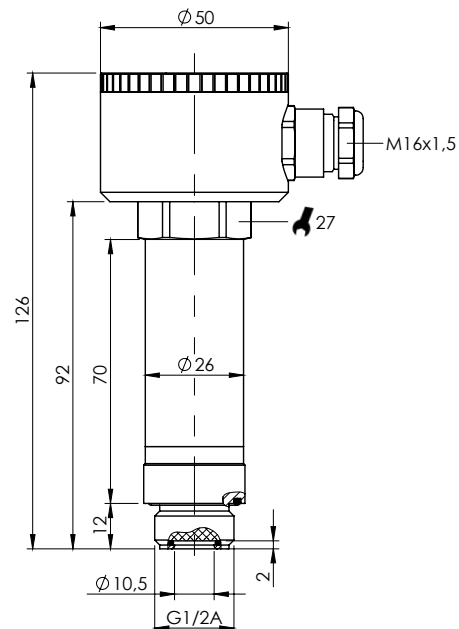

TYPE S

ORDERING CODE

Output signal

3 4...20 mA 3-Leiter

Ranges

Measuring ranges see table

99 Non-standard range (on request)

Process connection and material

G G 1/2 A a. 11,6 mm drill hole, ISO 228-1, 1.4404

S G 1/2 A a. 11,6 mm drill hole, ISO 228-1, 1.4404

9 Others (on request)

Sensor seal

1 FPM (Viton), standard

2 NBR (Perbuan)

3 EPDM

5 FFKM (Chemraz / Kalrez)

9 Others (on request)

Material Housing

1 Stainless steel 1.4301

Electrical connection

0 Cable gland M16x1,5

A Connector M12x1 4-pole

Options

0 None

IPR20- - - - -