

User manual IM1 – Multi-function device

Measuring inputs: Direct voltage, Direct current, Pt100(0), Thermocouple, Frequency, Rotation speed, Counter



Technical features:

- red display of -1999...9999 digits (optional: green, orange or blue display)
- minimal installation depth: 25 mm without plug-in terminal
- digit height 14 mm
- far range power supply 100-240 VAC or standard supply 230 VAC or 24 VDC
- display adjustment via factory presetting or directly on the sensor signal
- min/max-memory
- 5 adjustable supporting points
- display flashing at threshold value exceedance/undercut
- Tara-function
- sliding averaging
- programming interlock via access code
- protection class IP65 at the front
- pluggable screw terminal
- accessories: PC-based configuration software incl. CD and USB-adapter for devices without keypad and for a simple adjustment of standard devices.

Identification

STANDARD-TYPES	ORDER NUMBER
Multi-function measuring inputs	IM1-1UR4B.000X.S70xD
Housing size: 96x48 mm	IM1-1UR4B.000X.570xD
	IM1-1UR4B.000X.770xD

Options – break-down order key:

	IM	1	1	U	R	4	B	0	0	0	X	S	7	0	x	D		
Standard type M-Line																		Dimension <input type="checkbox"/> physical unit
Installation depth 38 mm incl. plug-in terminal			<input type="checkbox"/> 1															Version <input type="checkbox"/> internal version
Housing size 96x48x25 mm (BxHxD)			<input type="checkbox"/> 1															Switching points <input type="checkbox"/> 0 without
Display type Multi-function display				<input type="checkbox"/> U														Protection class <input type="checkbox"/> 1 without keypad, operation via PM-TOOL <input type="checkbox"/> 7 IP65/pluggable terminal
Display colours Green Red Orange Blue					<input type="checkbox"/> G <input type="checkbox"/> R <input type="checkbox"/> Y <input type="checkbox"/> B													Voltage supply <input type="checkbox"/> 5 230 VAC 50/60 Hz <input type="checkbox"/> 7 24 VDC galv. isolated <input type="checkbox"/> S 100-240 VAC / DC +/-10%
Number of digits 4-digit						<input type="checkbox"/> 4												Measuring input <input type="checkbox"/> X Voltage, Current, Temperature, Frequency
Digit height 14 mm							<input type="checkbox"/> B											Analog output <input type="checkbox"/> 0 without
Interface without								<input type="checkbox"/> 0										Sensor supply <input type="checkbox"/> 0 without

Please state physical unit by order, e.g. mbar

Contents

1. Brief description	1
2. Assembly	1
3. Electrical connection and connection examples	2
3.1. Terminal pin assignment	2
3.2. Connection examples	3
3.2.1. Voltage / Current	3
3.2.2. Pt100 / Pt1000 / Thermocouple	6
3.2.3. Frequency / Rotation speed	7
3.2.4. Counter	10
4. Description of function and operation	10
4.1. Operating and display elements	10
4.2. Programming software PM-TOOL	11
5. Setting-up the device	11
5.1. Switching on	11
6. Parameterisation	12
6.1. Selection of input signal, TYPE	12
6.1.1. Voltage/Current, VOLT, AMPE	13
Setting of the final and initial value, <i>END, ENDA, OFFS, OFFR</i>	
Setting of the decimal point, <i>DOT.A</i>	
Zero point slowdown of the input signal, <i>ZERO</i>	
Taring value, <i>TARA</i>	
Overflow/underflow behaviour, <i>OVER</i>	
Input of supporting points for linearisation of the measuring signal, <i>SPC.A</i>	
6.1.2. Pt100, Pt1000, Thermocouple, PT.SE, THER	15
Temperature device in °C/°F, <i>UNIT</i>	
Impedance matching, <i>OFFS</i>	
6.1.3. Pulse measuring, IMPU	16
6.1.3.1. Frequency, FREQ	16
Pulse triggering, <i>I.TYP</i>	
Range of frequency, <i>RANG</i>	
Filter, <i>FILT</i>	
Adjustment of final and initial value, <i>END, ENDF, OFFS, OFFF</i>	
Adjustment of the decimal point, <i>DOT.F</i>	
Taring value, <i>TARA</i>	
Input of supporting points for linearisation of the measuring signal, <i>SPC.F</i>	
6.1.3.2. Rotation speed, TURN	19
Pulse triggering, <i>I.TYP</i>	
Filter, <i>FILT</i>	
Pulse per turn, <i>PPT</i>	
Time base, <i>TIME</i>	
Adjustment of the decimal point, <i>DOT</i>	

Contents

6.1.3.3. Counter upwards/downwards, <i>CO.UP, CO.DN</i>	21
Pulse triggering, <i>I.TYP</i>	
Counter base / Input signal, <i>CO.BA</i>	
Wing, <i>EDGE</i>	
Prescaler, <i>PRES</i>	
Display value and pulse final numerical value, <i>END, END.C</i>	
6.2. General device parameter	23
Adjustment of measuring time, <i>SEC</i>	
Adjustment of the sliding average value, <i>GLN</i>	
Presentation of initial/final value in the display, <i>DI.HI, DI.LD</i>	
Allocation of functions onto the navigation keys, <i>TAST</i>	
Display flashing at threshold value exceedance/undercut, <i>FLAS</i>	
6.3. Alarm parameter	24
Limit value behaviour, <i>A1.FU, A2.FU</i>	
Alarm flashing in case of limit value errors, <i>A1.ER, A2.ER</i>	
Adjustment of the switching threshold, <i>A1.LI, A2.LI</i>	
Adjustment of the hysteresis, <i>A1.HY, A2.HY</i>	
Upper limit value, <i>A1.LD, A2.LD</i>	
Lower limit value, <i>A1.HI, A2.HI</i>	
Drop off delay, <i>A1.OF, A2.OF</i>	
Activation delay, <i>A1.ON, A2.ON</i>	
6.4. Safety parameter – locking of the parameterisation	26
Assignment of individual numerical codes, <i>CODE</i>	
Activation/Deactivation of the programming interlock, <i>RUN</i>	
7. Reset to default values	26
Setting back the parameter onto delivery condition	
8. Technical data	27
9. Safety advices	30
10. Error elimination	31

1. Brief description

The panel instrument **IM1-1U** is a 4-digit device for measuring of different kind of measuring signals such as direct voltage/direct current, temperature and frequency and a visual limit value monitoring via the display. The configuration happens via three front keys or via the optional PC-software PM-TOOL. An integrated programming interlock prevents unrequested changes of the parameter and can be released again via an individual code. The electrical connection happens on the rear side via plug-in terminals.

Selectable functions like e.g. the recall of the min/max-value, Tara-function, averaging, a direct change of the limit value in operating mode and additional measuring support points for linearisation complete the concept of a modern device.

2. Assembly

Please read the *Safety instructions* on page 30 before installation and keep this user manual for future reference.

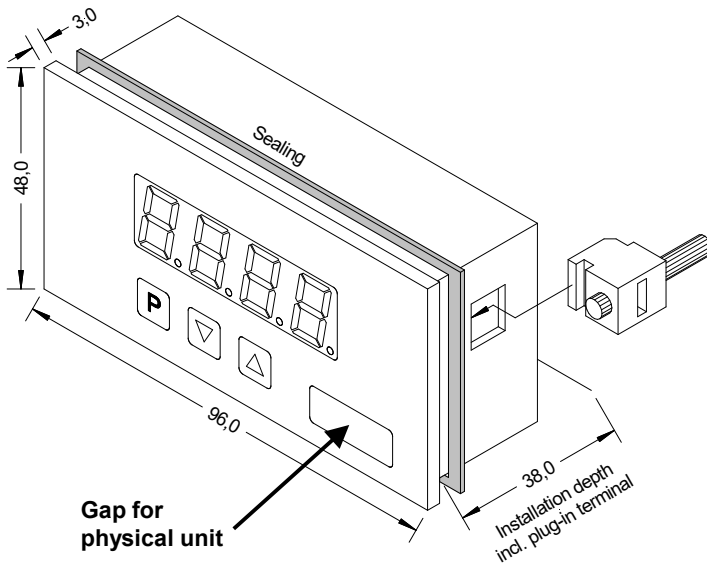

1. After removing the fixing elements, insert the device.
2. Check the seal to make sure it fits securely.
3. Click the fixing elements back into place and tighten the clamping screws by hand. Then use a screwdriver to tighten them another half a turn.

CAUTION! The torque should not exceed 0.1 Nm!

3. Electrical connection

3.1. Terminal pin assignment

Type **IM1-1UR4A.000X.S70xD** – supply 100-240 VAC, DC $\pm 10\%$

Type **IM1-1UR4A.000X.570xD** – supply 230 VAC 50/60 Hz

Type **IM1-1UR4A.000X.770xD** – supply 24 VDC galv. isolated

1	2	3	4	5	6	7
10 V, PNP (HTL)	AGND, Pt100(0)	50mV, TC, Pt100, Reset	1V, 2V, mA, Frequency, Pt100(0)		N	L
Signal inputs					100-240VAC or 230 VAC or 24 VDC - + Voltage supply	

3.2. Connection examples

Below please find some connection examples, which demonstrate some practical applications:

3.2.1. Current / Voltage

2-wire sensor 4...20 mA

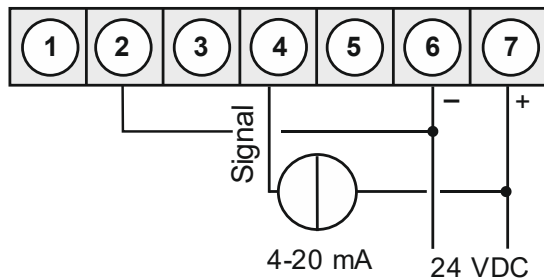

2-wire sensor 4...20 mA with external voltage source

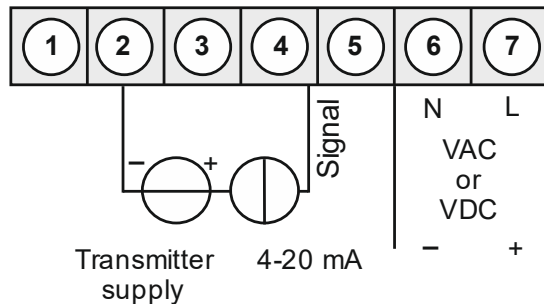

3-wire sensor 0/4...20 mA

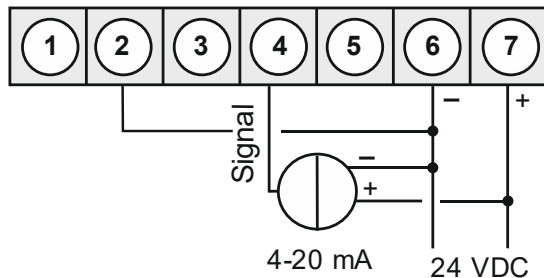

3-wire sensor 0/4...20 mA with external voltage source

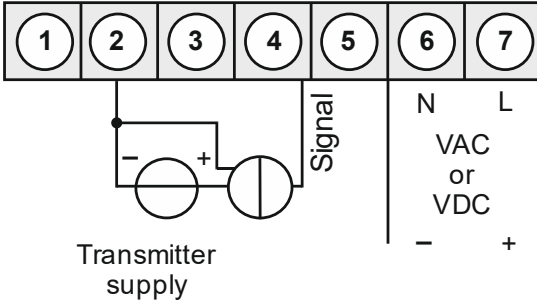

3-wire sensor 0/1/2...10 V

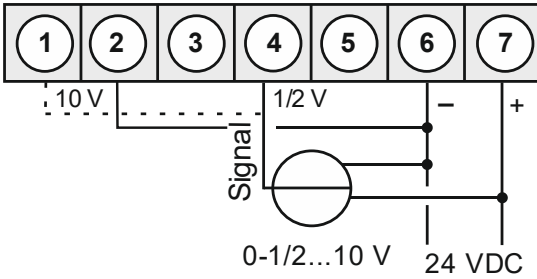

3-wire sensor 0-1/2...10 V with external voltage supply

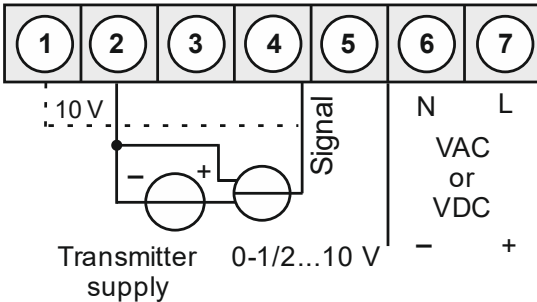

4-wire sensor 0/1/2...10 V, 50 mV

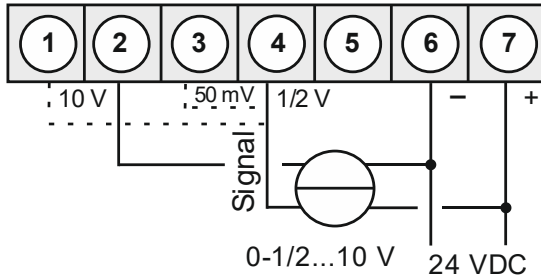

3-wire sensor 0-1/2...10 V, 50 mV with external voltage supply

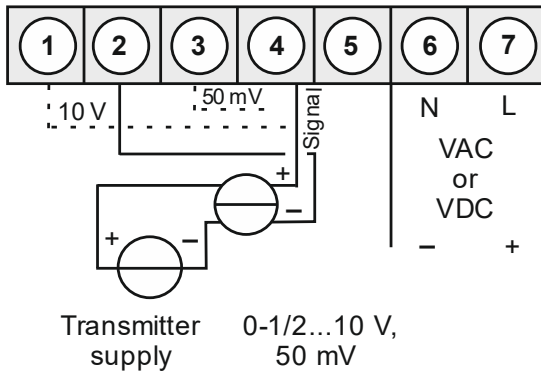

3.2.2. Temperature

Pt100 wire

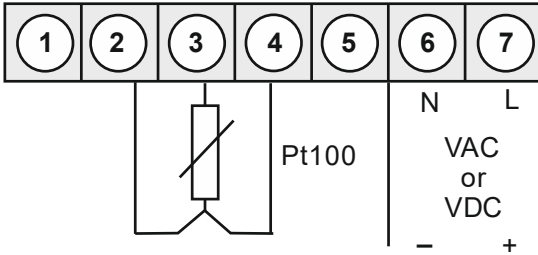

Pt1000 2-wire

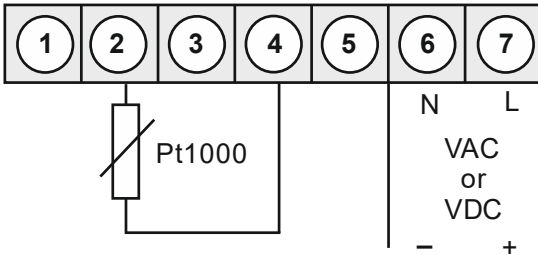

Thermocouple

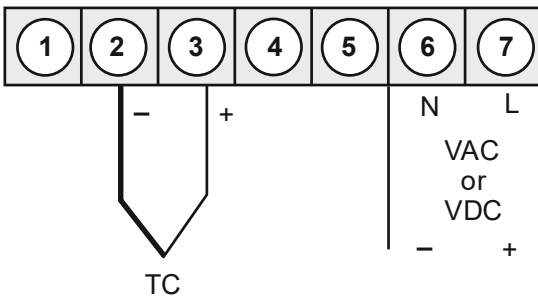

3.2.3. Frequency / Rotation speed

Encoder with TTL-output

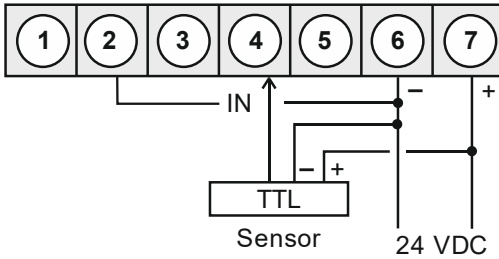

Encoder with external voltage source and TTL-output

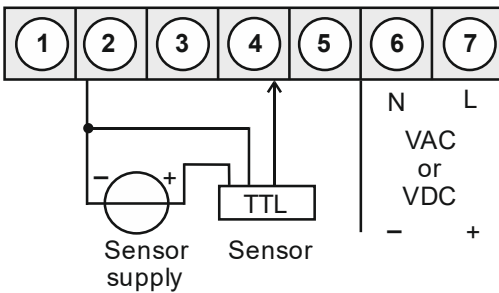

Encoder with PNP-output

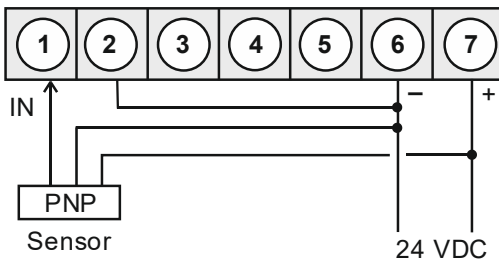

Encoder with NPN-output and required external resistance

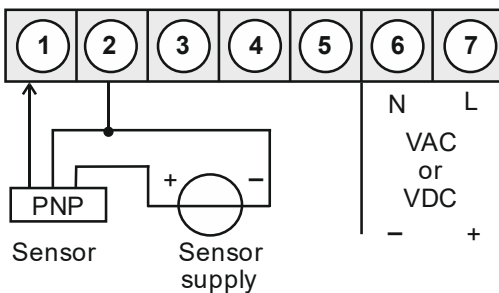

Encoder with NPN-output

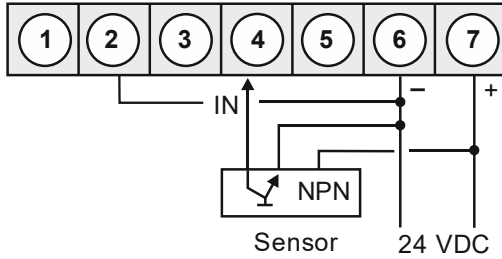

Encoder with external voltage source and NPN-output

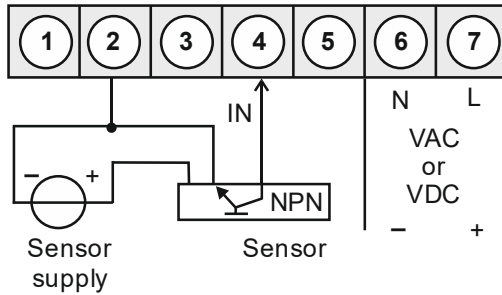

Encoder with NPN-output and necessary external resistance

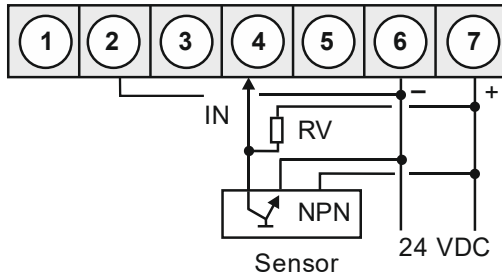

Encoder with external voltage source, NPN-output and necessary external resistance

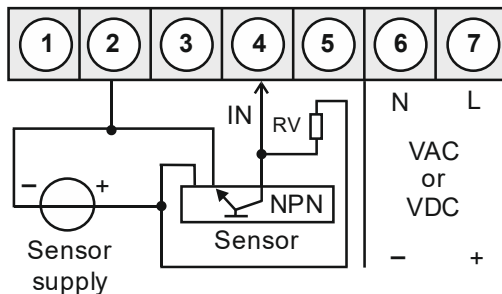

Encoder with PNP-output and external resistance circuit

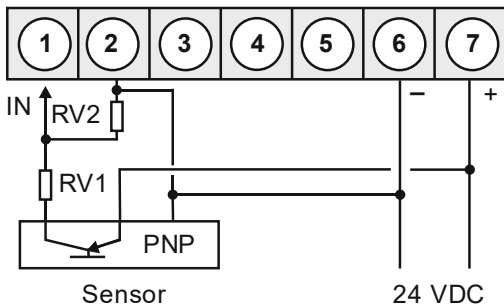

Encoder with external supply, PNP-output and external resistance circuit

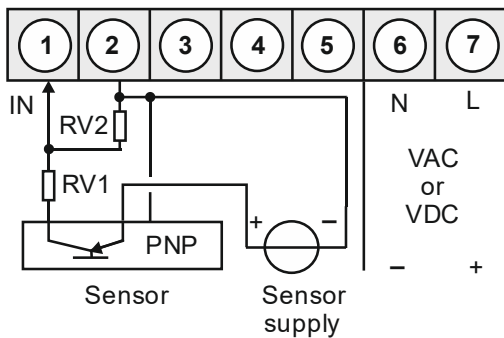

Encoder with external supply, Namur output

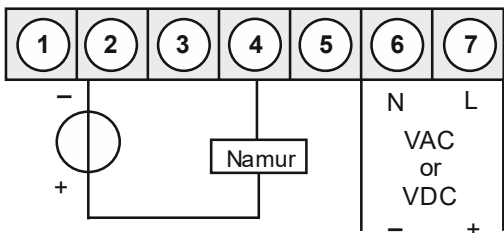

3.2.4. Counter

If the device is used as counter, please use the connection examples for frequency/rotation speed and follow the examples given below for a performed reset input:

Manual setting back via external feeler

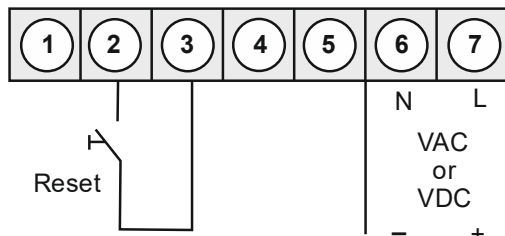

4. Description of function and operation

4.1. Operating and display elements

This device comes with three keys, which are used for parameterisation of the device and whose deposited functions can be called up during operation. Functions, that can be adjusted or changed are always signalised by a flashing of the display. Adjustments that were made in the „Parameterisation level“ are always confirmed with **[P]** and thus saved. The device saves however automatically all adjustments and changes back into operating mode, if no more key actuation takes place within 10 seconds.

Key symbol	Function in operating mode	Function at parameterisation
Program key [P]	Change the parameterisation with program key [P] .	Change into a lower parameterisation-level or to deposited values.
Minus key [▼]	Depending on adjusted key functions, use the minus key [▼] for calling up the minimum value or changing a lower limit value.	Change between parameter and changing of parameter within the value level.
Plus key [▲]	Depending on adjusted key functions, use the plus key [▲] for calling up the maximum-value or changing a lower limit value.	Change between parameter and changing of parameter within the value level.

A switched-on relay or an activated switching point will be reported optically by a flashing of the respective switching point LED next to the 7-segment display. A display over-/underflow is displayed by four bars „- - - -“.

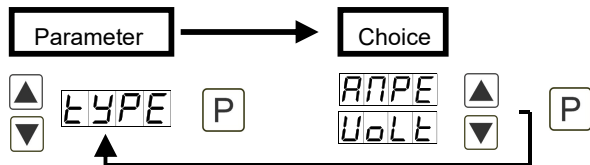
Example: Setting up the device parameter, e.g. selection of the input signal**Example: Setting up numerical values, e.g. final value of measuring range**

Numerical values are adjusted from the smallest to the highest digit with [▲] [▼] and confirmed digit per digit with [P]. A minus sign can only be adjusted on the leftmost digit. After the last digit, the display changes back into menu-level.

4.2. Programming via configuration software PM-TOOL MUSB4:

The software comes on CD incl. an USB-cable with a device adapter. The connection happens via a 12-pole micromatch connector plug on the back and the PC is connected via an USB connector plug.

System requirements: PC with USB interface

Software: Windows XP, Windows Vista

With this tool the device configuration can be created, readout and saved on the PC. Via the easy to handle program surface the parameter can be changed, whereat the mode of operation and the possible selection options can be preset via the program.

CAUTION!

During parameterisation with a connected measuring signal, make sure that the measuring signal has no mass supply to the programming plug. The programming adapter is galvanically not isolated and directly connected with the PC. Via polarity of the input signal, a current can discharge via the adapter and destroy the device as well as other connected components!

5. Setting-up the device**5.1. Switching on**

Once the installation is complete, start the device by applying the voltage supply. Check beforehand once again that all the electrical connections are correct.

Starting sequence

For 1 second during the switching-on process, the segment test (8 8 8 8 8) is displayed, followed by an indication of the software type and, after that, also for 1 second, the software version. After the start-up sequence, the device switches to operating/display mode.

6. Parameterisation

6.1. Selection of the input signal: type

During the adjustment of the type, an allocation of the input version takes place. Selectable are 5 input types: Voltage, Current, Pt100(0), Thermocouple and Pulse signal.

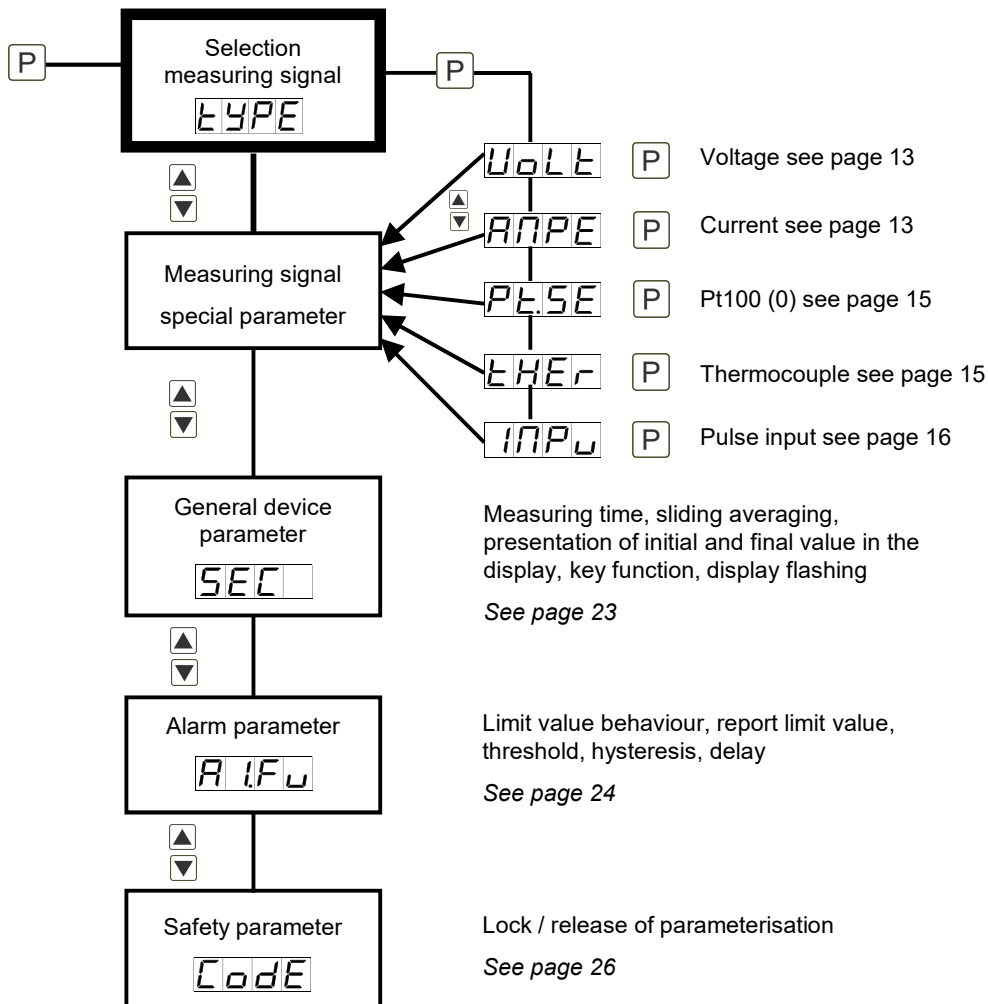



6.1.1. Device parameter for the allocation of voltage/current signals: VoLT, AMPE

VoLT: 4 voltage signals are available: 0-10 V, 0-2 V, 0-1 V and 0-50 mV

AMPE: Choose between the following signals: 0-20 mA and 4-20 mA

Parameter	Menu item	Default				
VoLt	VoLT	0-10	0-2	0-1	0-50	0-10
	SEnU					
AMPE	ANPE	0-20	4-20	SEnA		0-20

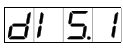
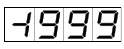
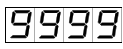
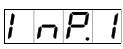
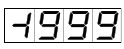
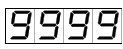
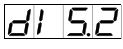
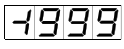
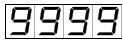
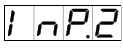
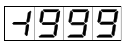
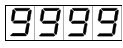
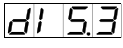
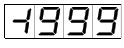
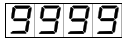
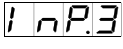
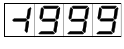
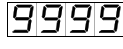
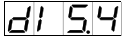
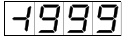
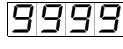
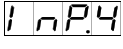
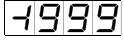
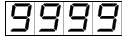
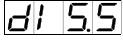
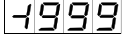
Parameter	Menu item	Default			
End	End	1999	to	9999	1000
	with SEnU or SEnA		additional	noCA CAL	
OFFS	OFFS	1999	to	9999	0000
	with SEnU or SEnA		additional	noCA CAL	
dot.A	dot.A	0000	to	0000	0000
EndA	EndA	1999	to	9999	1000
OFFA	OFFA	1999	to	9999	0000
tArA	tArA	1999	to	9999	0000
ZErO	ZErO	00	to	99	00
OUEr	OUEr	no	AdC	rAnG	S Pr
	10Pr				no
SPC.A	SPC.A	0000	to	0005	0000

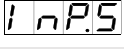
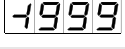
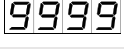
Parameter		Menu item			Default	
dIS.1	 dI 5.1	 4999	to	 9999		
InP.1	 InP.1	 4999	to	 9999		
dIS.2	 dI 5.2	 4999	to	 9999		
InP.2	 InP.2	 4999	to	 9999		
dIS.3	 dI 5.3	 4999	to	 9999		
InP.3	 InP.3	 4999	to	 9999		
dIS.4	 dI 5.4	 4999	to	 9999		
InP.4	 InP.4	 4999	to	 9999		
diS.5	 dI 5.5	 4999	to	 9999		
InP.5	 InP.5	 4999	to	 9999		

End / OFFS: Upper range value/lower range value

By use of these values, the desired display value can be allocated to the measuring signal. If **Sen.V** or **Sen.A** was selected as the input type, you can choose between **noCA** and **CAL**. With **noCA**, the previously set display value is adopted, with **CAL** the adjustment is carried out over the measuring section and the analog input value is adopted.

dot.A: Comma / decimal place

Determine the decimal representation of the display value with the decimal point. It is used for the adjustment of the limit values, too.

EndA / OFFA: Rescale the measuring input values

With this function the final value/initial value can be rescaled to e.g. 19.5 mA / 3.2 mA without application of the measuring signal.

tArA: Setting up the Tara value / Offset value

The preset value is added to the linearised value. So the characteristic line can be shifted by the selected amount.

ZERo: Zero-point slowdown

Here, a range of values around the zero-point can be preset, where the display shows a zero. If e.g. a 10 is adjusted, the display would show a zero within a range of value of -10 to +10 and continue below with -11 and above with +11.

OVER: Overflow and underflow behaviour

The overflow/underflow of the measuring input will be signaled by 4 horizontal bars at the top respectively by 4 bars at the bottom. Exception is input type „4-20“ (mA), where a measurand smaller than 1 mA can already be valuated as underflow. This shall indicate a sensor failure.

no	No additional check of the range takes place. By leaving the display range, the display remains on the smallest value „ dl.Lo “ respectively highest value „ dl.HI “.
AdC	At exceedance/undercut of the display range „ dl.Lo “ / „ dl.HI “ over-/underflow will be displayed.
rAnG	The measuring signal needs to be exactly in the preset measuring range „ EnD “/“ OFFS “, so that an overflow will not be detected. The display range and transformer range will be monitored additionally.
5 Pr	The measuring signal is monitored over $\pm 5\%$ of the adjusted measuring range. The display range will be monitored additionally.
10 Pr	The measuring signal is monitored over $\pm 10\%$ of the adjusted measuring range. The display range will be monitored additionally.

SPC.A: Number of additional supporting points

To linearise nonlinear sensor values, five additional supporting points can be defined for the initial and final value. Only the activated supporting point parameters are shown.

dis1...dis5: Display values for supporting points

Under this parameter supporting points are defined on a value basis.

INP1...INP5: Analog values for supporting points

The supporting points are always preset according to the selected input signal ma/V. Here, desired analog values can be freely adjusted in ascending order.

6.1.2. Device parameter for the allocation of Pt100(0), Thermocouple: Pt.SE, tHER**Pt.SE:** Three types are available:

Pt.Lo: Pt100 3-wire -50.0...200.0°C / -58.0...392.0°F

Pt.Hi: Pt100 3-wire -200...850°C / -328...1562°F

Pt.tH: Pt1000 2-wire -200...850°C / -328...1562°F

tHER: Select between: **Thermocouple types L, J, K, B, S, N, E, T, R**

Parameter	Menu item	Default
Pt.SE	Pt.Lo Pt.Hi Pt.tH	Pt.Lo

Parameter	Menu item	Default
tHER	L J K B S N E T R	L

Parameter	Menu item				Default
Unlt	Unlt	°C	°F		°C
OFFS	OFFS	-19.9	to	19.9	
		-35.9	to	35.9	0000

Unlt: Type of temperature measurement

Select, if the temperature shall be displayed in °C or °F with **Unlt**.

OFFS: Impedance matching

The value alignment at a temperature measuring in °C can be adjusted between -20,0 and +20,0 and for a later measurement in °F between -36 and +36. If the measuring type is changed later, the value will be rounded.

General device parameter see page 23

Alarm parameter see page 24

Safety parameter for lock / release of parameterisation see page 26

6.1.3. Device parameter for the allocation of pulse signals: IMPU

FrEq: Frequency measuring of TTL-signals, PNP/NPN-sensors.

tUrn: Rotation speed measurement (simplified adjustment option) of TTL-signals, PNP/NPN-sensors.

A flow rate can be scaled with this function, too.

CO.up: Counting input (upwards) for TTL-signals, PNP/NPN-sensors.

CO.on: Counting input (downwards) for TTL-signals, PNP/NPN-sensors.

6.1.3.1. Frequency measurement

P	TYPE	UOLT	RANPE	PLSE	ETHER	INPU	P
---	------	------	-------	------	-------	------	---

Parameter	Menu item				Default
IMPu	INPU	FrEq			

Parameter	Menu item					Default
I.TYP	ITYP	tTL	nPN	pNP	nAN	tTL
rAnG	rANG	9999	9999	9999	9999	9999
FILt	FILT	no	2	5	10	no
		20	50	100	200	
		500				

Parameter	Menu item		Default	
End	End	4999	to 9999	1000
OFFS	OFFS	4999	to 9999	0000
dot.F	dot.F	0	to 0000	0
End.F	End.F	0000	to 9999	1000
OFF.F	OFF.F	0000	to 9999	0000
tArA	tArA	4999	to 9999	0
SPC.F	SPC.F	0	to 5	0
diS.1	diS.1	4999	to 9999	
InP.1	InP.1	4999	to 9999	
diS.2	diS.2	4999	to 9999	
InP.2	InP.2	4999	to 9999	
diS.3	diS.3	4999	to 9999	
InP.3	InP.3	4999	to 9999	
diS.4	diS.4	4999	to 9999	
InP.4	InP.4	4999	to 9999	
diS.5	diS.5	4999	to 9999	
InP.5	InP.5	4999	to 9999	

I.tYP: Pulse signal

There are three modes for the triggering of the pulse input:

ttl	Active TTL-signals with approx. 0.8 V lower and approx. 2 V upper threshold.
nPn	Passive switching contact, which operates the internal pull-up depending on the rate.
PnP	Active sensor output. A pull-down is operated in the device.
nAM	Namur output Low <1,5mA, High > 2,5mA

rAnG: Selection of the frequency range

A selection of four frequency ranges is available:

9.999	0...9,999 Hz (automatic software filter on 100 Hz/5ms)
99.99	0...99,99 Hz (automatic software filter on 500 Hz/5ms)
999.9	0...999,9 Hz
9999	0...9999 Hz (approximate 10 kHz)

FILT: Limitation of the pulse length

For contact bounce suppression of mechanical contacts via selection of the filter frequency.

no	No particular evaluation of the pulse length.
2	2 Hz with pulse-duty factor 1:1 => minimal pulse length 250 ms
5	5 Hz with pulse-duty factor 1:1 => minimal pulse length 100 ms
10	10 Hz with pulse-duty factor 1:1 => minimal pulse length 50 ms
20	20 Hz with pulse-duty factor 1:1 => minimal pulse length 25 ms
50	50 Hz with pulse-duty factor 1:1 => minimal pulse length 10 ms
100	100 Hz with pulse-duty factor 1:1 => minimal pulse length 5 ms
500	500 Hz with pulse-duty factor 1:1 => minimal pulse length 1 ms

End / OFFS: Upper range value/lower range value

By use of these values, the desired display value can be allocated to the measuring signal.

dot.F: Comma / decimal place

Determine the decimal representation of the display value with the decimal point. It is used for the adjustment of the limit values, too.

End.F / OFF.F: Rescale the measuring input values

With this function the final value/initial value can be rescaled without application of the measuring signal.

tArA: Setting up the Tara-/Offset value

The preset value is added to the linearised value. So the characteristic line can be shifted by the selected amount.

SPC.F: Number of additional support points

To linearise nonlinear sensor values, five additional support points can be defined for the initial value and final value. Only the activated support point parameter are shown.

dis1...dis5: Display values for support points

Under this parameter support points are defined on a value basis.

INP1...INP5: Analog values for support points

The support points are always preset according to the selected input signal ma/V. Here, desired analog values can be freely adjusted in ascending order.

6.1.3.2. Rotation speed measurement

As more than 80% of the frequency measurement applications are referring to a rotation speed, there is a simplified adjustment mode available via type „Turn“. A flow rate can be scaled with this function, too.



Parameter	Menu item	Default
IMPu	INPu	turn

Parameter	Menu item	Default
I.tYP	tTL	nPn
FILt	no	2
	20	50
	100	200
	500	
PPt	0001	to 9999
tIME	SEC	n In
dot	0	to 0000

I.tYP: Pulse signal

There are 3 modes for the triggering of the pulse input:

tTL	Active TTL-signals with approx. 0.8 V lower and approx. 2 V upper threshold.
nPn	Passive switching contact, which operates the internal pull-up depending on the rate.
PnP	Active sensor output. A pull-down is operated in the device.
nAM	Namur output Low <1,5mA, High > 2,5mA

FILt: Limitation of the pulse length

For contact bounce suppression of mechanical contacts via selection of the filter frequency.

no	No particular evaluation of the pulse length
2	2 Hz with pulse-duty factor 1:1 => minimal pulse length 250 ms
5	5 Hz with pulse-duty factor factor 1:1 => minimal pulse length 100 ms
10	10 Hz with pulse-duty factor factor 1:1 => minimal pulse length 50 ms
20	20 Hz with pulse-duty factor 1:1 => minimal pulse length 25 ms
50	50 Hz with pulse-duty factor 1:1 => minimal pulse length 10 ms
100	100 Hz with pulse-duty factor 1:1 => minimal pulse length 5 ms
500	500 Hz with pulse-duty factor 1:1 => minimal pulse length 1 ms

PPt: Pulse per rotation

With this parameter the number of pulse per rotation can be entered directly. It generally works with sprockets and their number of sprockets, incremental encoder and their resolution or glands with a number of boreholes. For simple flow meter with impeller it is only necessary to enter the number of pulse per liter or cubic metre.

tIME: Time base

In general the time base for rotation speed is always set on „Min“, it can of course be changed into seconds or hours.

dot: Comma / decimal place

Determine the decimal representation of the display value with the decimal point. A rotation speed with up to 3 positions after decimal point can be displayed, if they are small enough.

Example: Rotation speed measurement

The rotation speed of a roller in a steel works needs to be displayed in turns/minute with one position after decimal place. The rotational speed will be recorded via a perforated disc with 18 holes, positioned in an angle of 20°. The maximum rotation speed of the roller is 60 turns/minute. Like this, adjust for example **FILt = 100**; **PPt = 18**; **tIME = Min**; **dot = 0.0**. The difficulty with the adjustment of the filter is to calculate the pulse length precisely.

6.1.3.3. Upwards/downwards counter



Parameter	Menu item	Default
IMPu	INPu	CoUP

Parameter	Menu item	Default
I.tYP	tTL	nPn
Co.bA	PuLS	SEC
EdGE	Pos1	nEGR
PrES	0001	to 9999
FILt	no	2 5 10
	20 50 100 200	
	500	
End	1999	to 9999
End.C	0001	to 9999
dot	0	to 0.000

I.tYP: Pulse signal

There are three modes for the triggering of the pulse input:

ttL	Active TTL-signals with approx. 0.8 V lower and approx. 2 V upper threshold.
nPn	Passive switching contact, which operates the internal pull-up depending on the rate.
PnP	Active sensor output. A pull-down is operated in the device.
nAM	Namur output Low <1,5mA, High > 2,5mA

Co.bA: Counter base

As standard the device records incoming pulses during counter operation. However the counter basis can also be used as system time in seconds or minutes. In doing so the pulse input turns into gate time, it counts at wing **PoSI** (HIGH-signal) and stands at **LOW**. The logic is contrary at wing **nEGA**.

EdGE: Counting start / counting end (wing)

The active wing declares when the counting takes place. The pulse recording **PuLS** is chosen as counter basis, via this it will be declared if the internal counter will be increased by the positive wing **PoSI** or the negative wing **nEGA**. If time is taken as time basis, then the active-triggering/HIGH-triggering will be selected with **PoSI** and the passive triggering/LOW-triggering will be selected with **nEGA**. The counter reset is always statical.

PrES: Prescaler

A prescaling in the device happens via the prescaler, so even large pulse numbers like e.g. 5.000.000 can be recorded by the device. Only the prescaled value will be included for the scaling.

FILt: Limitation of the pulse length

For contact bounce suppression of mechanical contacts via selection of the filter frequency:

no	No particular evaluation of the pulse length
2	2 Hz with pulse-duty factor 1:1 => minimal pulse length 250 ms
5	5 Hz with pulse-duty factor factor 1:1 => minimal pulse length 100 ms
10	10 Hz with pulse-duty factor factor 1:1 => minimal pulse length 50 ms
20	20 Hz with pulse-duty factor 1:1 => minimal pulse length 25 ms
50	50 Hz with pulse-duty factor 1:1 => minimal pulse length 10 ms
100	100 Hz with pulse-duty factor 1:1 => minimal pulse length 5 ms
500	500 Hz with pulse-duty factor 1:1 => minimal pulse length 1 ms

End, End.C: Display terminal value and pulse terminal value

The display value can be freely linearised via the prescaled pulse number. For this the number of desired pulses will be allocated to a display value. The zero-point cannot be prescaled. At a backwards counter **End** and **End.C** serve as start value. For the absolute counter threshold values, the adjustments of **dl.HI** and **dl.Lo** are used. By reaching them, all digits that reached this value are flashing, what equates an underflow/overflow.

General device parameter see page 23

Alarm parameter see page 24

Safety parameter for lock / release of parameterisation see page 26

6.2. General device parameter

Parameter	Menu item				Default	
SEC	SEC	00.1	to	20	100	
GLM	GLM	01	to	20		
dl.HI	dl.HI	4999	to	9999	4999	
dl.Lo	dl.Lo	4999	to	9999	9999	
tASt	tASt	no	EHtr	ALL1	no	
FLAS	FLAS	no	AL-1	AL-2	AL.12	no

SEC: Measuring time

Adjustment of basic measuring time respectively of the frequency filter for a relief of the measurand. This filter value is adjustable from 0.01...2.00 seconds. At pulse measurement, the value can be selected up to 0.00, so that the identification runs on maximum speed.

GLM: Sliding averaging

Besides the measuring time, a sliding averaging of 1...20 values can be activated, too. Here, no separate emphasis between the past values is taking place. At **GLM** = 1 the sliding averaging is switched off.

dl.Lo, dl.HI: Presentation of initial/end value in the display

For overflow evaluation the measuring range and the optional selected overflow (**OVER**) behaviour are evaluated. In addition this range can be limited by the parameter **dl.HI** and **dl.Lo**.

tASt: Allocation (deposit) of key functions

For operating mode either a min/max-value monitoring or a limit value correction on the navigation keys can be deposited here. If the min/max memory is activated by **EHtr**, the measured min/max-values will be saved during operation and can be recalled via the navigation keys **[▲]** **[▼]**. At restart of the device, all values are lost. If the limit value correction **AL.LI** is selected, limit values can be changed during operation, without interfere with the operating procedure. If **no** is adjusted, the navigation keys **[▲]** **[▼]** are without any function in the operating mode.

FLAS: Display flashing at threshold value exceedance/undercut

A display flashing can be added as additional alarm function either to the first limit value (select: **AL-1**), to the second limit value (select: **AL-2**) or to both limit values (select: **AL-12**). With **no** (factory settings), no flashing is allocated.

6.3. Alarm parameter

Parameter	Menu item				Default	
Al.Fu	A1Fu	oFF	on	HIL1	LoL1	
		rRnG	Out.r	Ac.H1	Ac.Lo	oFF
Al.Er	A1Er	oFF	on			oFF
Al.LI	A1LI	-9999	to	9999		100
Al.HY	A1HY	0000	to	9999		0
Al.HI	A1HI	-9999	to	9999		200
Al.Lo	A1Lo	-9999	to	9999		100
Al.oF	A1oF	0000	to	5999		0
Al.on	A1on	0000	to	5999		0
A2.Fu	A2Fu	oFF	on	HIL1	LoL1	
		rRnG	Out.r	Ac.H1	Ac.Lo	oFF
A2.Er	A2Er	oFF	on			oFF
A2.LI	A2LI	-9999	to	9999		300
A2.HY	A2HY	0000	to	9999		0
A2.HI	A2HI	-9999	to	9999		400
A2.Lo	A2Lo	-9999	to	9999		300
A2.oF	A2oF	0000	to	9999		0
A2.on	A2on	0000	to	9999		0

A1.Fu, A2.Fu: Limit value behaviour

Change between the different working types of switching outputs by using the functional principle. If **Ax.Fu = oFF** was selected, the relevant switching point parameter will not be displayed.

oFF	The switching point is without function and relevant parameter will not be displayed (Default status).
On	The switching point is switched on during measuring operation and corresponding parameter (except Ax.Er and Ax.tY) will not be displayed.
HI-LI	Switch at threshold value exceedance.
Lo.LI	Switch at threshold value undercut.
rAnG	Switch within the preset range.
Out.r	Switch outside the preset range.

A1.Er, A2.Er: Alarm flashing in case of limit value errors

on	Display flashes in case of limit value errors.
oFF	Optical alarm not active (no flashing in case of limit value errors).

A1.L1, A2.L1: Threshold level

Here the threshold level is defined that activates/deactivates an alarm. This parameter will not be recalled if the window function is used.

A1.HY, A2.HY: Hysteresis

The hysteresis defines a difference to the limit value which defines the delay of an alarm. This parameter will not be recalled if the window function is used.

A1.HI, A2.HI: Upper limit value**A1.Lo, A2.Lo:** Lower limit value

For range functions **A1.FU, A2.FU = rAnG** or **Out.r** this value defines the upper/lower limit of the window function between „-1999...9999“. This parameter will not be displayed with other functional principles. The functional principle can change between switching point 1 and 2.

A1.oF, A2.oF: Dropout delay

Preset a delayed switching off of 0-5999 seconds for the limit values. The time value will not be saved permanently and is set back by restart of the device. Furthermore the alarm condition will be detected during restart, without considering the preset delay.

A1.on, A2.on: On-delay

Preset a delayed switching on of 0-5999 seconds for the limit values. The time value will not be saved permanently and is set back by restart of the device. Furthermore the alarm condition will be detected during restart, without considering the preset delay.

6.4. Safety parameter for lock/release of parameterisation

Parameter	Menu item		Default
CodE	Code	0000 to 9999	1234
run	run	ULOC LOC	ULOC

CodE: Assignment of an individual numerical code (4-digit number combination, free allocatable)

With assignment of this code (0000 factory settings), all parameter will be locked for the user, if **LOC** was selected afterwards under menu item **run**. By pushing **[P]** in operating mode for approx 3 seconds, the message **CodE** appears in the display. The code needs to be entered before each parameterisation, until the programming is released with **ULoC** under **run**.

run: Activation/Deactivation of programming interlock

Select with **[▲]** **[▼]** between deactivated key lock **ULOC** (factory settings) and activated key lock **LOC**. The keypad is locked, if **LOC** was selected. To get into menu level again, **[P]** needs to be pushed for 3 seconds in operating mode. The now appearing **CodE** (factory settings 0000) needs to be entered with **[▲]** **[▼]** and **[P]** and releases the keypad. A faulty entry will be displayed with **FAIL**.

In **LOC**-mode the device cannot be resetted, which shall additionally secure the regular operation.

7. Reset to default values (factory settings)

To set the device into a defined initial state, there is the possibility to do a reset to the default values. Please proceed as follows:

Switch off the voltage supply of the device. Push the **[P]**-key and switch voltage supply on with in-position **[P]**-key. Push the **[P]**-key until „----“ appears in the display. Due to the reset, default values are charged and used for further operation. The device is now reset to the delivery state.

ATTENTION!

All application related data are lost!

8. Technical data

Housing				
Dimensions	96x48x25 mm (WxHxD)			
	96x48x38 mm (WxHxD) including plug-in terminal			
Panel cut-out	92.0 ^{+0.8} x 45.0 ^{+0.6} mm			
Wall thickness	up to 3 mm			
Fixing	screw elements			
Material	PC Polycarbonate, black, UL94V-0			
Sealing material	EPDM, 65 Shore, black			
Protection class	standard IP65 (front panel), IP00 (back side)			
Weight	approx. 100 g			
Connection	plug-in terminal; wire cross-section up to 2.5 mm ²			
Display				
Digit height	14 mm			
Segment colour	red (optional green, orange or blue)			
Display range	-1999 to 9999			
Limit values	optical display flashing			
Overflow	horizontal bars at the top			
Underflow	horizontal bars at the bottom			
Display time	0.1 to 10.0 seconds			
Signal	Measuring range	Measuring span	Resolution	Internal resistance
Voltage	0...10 V	0...12 V	≥ 14 bit	Ri > 100 kΩ
Voltage	0...2 V	0...2.2 V	≥ 14 bit	Ri ≥ 10 kΩ
Voltage	0...1 V	0...1.1 V	≥ 14 bit	Ri ≥ 10 kΩ
Voltage	0...50 mV	0...75 mV		Ri ≥ 10 kΩ
Current	4...20 mA	1...22 mA		Ri = ~125 Ω
Current	0...20 mA	0...22 mA		Ri = ~125 Ω
Pt100-3-wire	-50...200°C	-58...392°F	0.1°C / 0.1°F	
Pt100-3-wire	-200...850°C	-328...1562°F	1°C / 1°F	
Pt1000-2-wire	-200...850°C	-328...1562°F	1°C / 1°F	
Thermo K	-270...1350°C	-454...2462°F	1°C / 1°F	
Thermo S	-50...1750°C	-328...3182°F	1°C / 1°F	

Signal	Measuring range	Measuring span	Resolution	Internal resistance
Thermo N	-270...1300°C	-454...2372°F	1°C / 1°F	
Thermo J	-170...950°C	-274...1742°F	1°C / 1°F	
Thermo T	-270...400°C	-454...752°F	1°C / 1°F	
Thermo R	-50...1768°C	-58...3214°F	1°C / 1°F	
Thermo B	80...1820°C	176...3308°F	1°C / 1°F	
Thermo E	-270...1000°C	-454...1832°F	1°C / 1°F	
Thermo L	-200...900°C	-328...1652°F	1°C / 1°F	
Frequency	0...10 kHz	0...10 kHz	0,001 Hz	
NPN	0...3 kHz	0...3 kHz	0,001 Hz	
PNP	0...1 kHz	0...1 kHz	0,001 Hz	
Rotation speed	0...9999 1/min	0...9999 1/min	0,001 1/min	
Counter	0...9999 (Prescaler up to 1000)			
Pulse input				
	TTL	HTL/PNP	NPN	Namur
	Low <2 V, High >3 V	Low <6 V, High >8 V	Low <0.8 V, High via resistance	Low <1.5 mA, High >2.5 mA
Reste-input	active <0.8 V			
Measuring error				
Standard	0.2% of measuring range ± 1 digit			
Pt100/Pt1000	0.5% of measuring range ± 1 digit			
Thermocouple	0.3% of measuring range ± 1 digit			
Accuracy				
Reference junction	± 1°C			
Drift of temperature	100 ppm / K			
Measuring time	0.01...2.0 seconds			
Sampling rate	approx. 1/s at thermocouple, approx. 100/s at standard signals			
Measuring principle	U/F-conversion			
Resolution	approx. 14 bit at 1s measuring time			

Output	
Interface	Configuration interface for PC-software PM-TOOL with USB-dongle
Power supply	100-240 VAC 50/60 Hz, DC \pm 10% 230 VAC 50/60 Hz \leq 3 VA 24 VDC galvanic isolated \leq 1 VA
Memory	
	EEPROM
Data life	\geq 100 years at 25°C
Ambient condition	
Working temperature	-20°C...+50°C
Storing temperature	-30°C...+70°C
Weathering resistance	relative humidity 0-85% on years average without dew
EMV	
	EN 61326
CE-identification	Conformity according to directive 2014/30/EU
Safety standard	According to low voltage directive 2014/35/EU EN 61010; EN 60664-1

9. Safety advices

Please read the following safety advices and the assembly *chapter 2* before installation and keep it for future reference.

Proper use

The **IM1-1U-device** is designed for the evaluation and display of sensor signals.



Danger! Careless use or improper operation can result in personal injury and/or damage the equipment.

Control of the device

The panel meters are checked before dispatch and sent out in perfect condition. Should there be any visible damage, we recommend close examination of the packaging. Please inform the supplier immediately of any damage.

Installation

The **IM1-1U-device** must be installed by a suitably **qualified specialist** (e.g. with a qualification in industrial electronics).

Notes on installation

- There must be no magnetic or electric fields in the vicinity of the device, e.g. due to transformers, mobile phones or electrostatic discharge.
- **The fuse rating of the supply voltage should not exceed a value of 0.5A N.B. fuse!**
- Do not install **inductive consumers** (relays, solenoid valves etc.) near the device and **suppress** any interference with the aid of RC spark extinguishing combinations or free-wheeling diodes.
- Keep input, output and supply lines separate from each other and do not lay them parallel with each other. Position "go" and "return lines" next to one another. Where possible use twisted pair. So, the best measuring results can be received.
- Screen off and twist sensor lines. Do not lay current-carrying lines in the vicinity. Connect the **screening on one side** on a suitable potential equaliser (normally signal ground).
- The device is not suitable for installation in areas where there is a risk of explosion.
- Any electrical connection deviating from the connection diagram can endanger human life and/or can destroy the equipment.
- The terminal area of the devices is part of the service. Here electrostatic discharge needs to be avoided. Attention! High voltages can cause dangerous body currents.
- Galvanically isolated potentials within one complex need to be placed on an appropriate point (normally earth or machines ground). So, a lower disturbance sensibility against impacted energy can be reached and dangerous potentials, that can occur on long lines or due to faulty wiring, can be avoided.

10. Error elimination

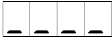
	Error description	Measures
1.	<p>The unit permanently indicates overflow.</p> 	<ul style="list-style-type: none"> • The input has a very high measurement, check the measuring circuit. • The display range of 999 respectively the preset measuring range was exceeded, control the supporting points respectively the selected input type and signal range. Not all of the activated supporting points are parameterised. Check if the relevant parameters are adjusted correctly.
2.	<p>The unit permanently shows underflow.</p> 	<ul style="list-style-type: none"> • The input has a very low measurement, check the measuring circuit. • The display range of -1999 respectively the preset measuring range was undercut, control the adjustments. • Not all of the activated supporting points are parameterised. Check if the relevant parameters are adjusted correctly.
3.	<p>The device shows Lbr in the 7-segment display.</p>	<ul style="list-style-type: none"> • Check if the selected input type is correct. Only temperature measurements and 4...20 mA show these kind of error indication. • Check the wiring regarding a contact and correct connection.
4.	<p>The device shows HELP in the 7-segment display.</p>	<ul style="list-style-type: none"> • The device has detected an error in the configuration memory, operate a reset to default values and configurate the device according to your application.
5.	<p>Parameter for the parameterisation of the input are not available.</p>	<ul style="list-style-type: none"> • The programming interlock is activated. • Enter correct code.
6.	<p>The device shows Err1 in the 7-segment display.</p>	<ul style="list-style-type: none"> • Contact the manufacturer if errors of this kind occur.
7.	<p>The device does not react as expected.</p>	<ul style="list-style-type: none"> • If you are not sure, if the device has been parameterised before, restore the delivery state as described in <i>chapter 7</i>.
8.	<p>There are higher constant errors of indication at thermocouple measurement.</p>	<ul style="list-style-type: none"> • Remove strong heat or cold sources from the direct surroundings of the device. • Reduce the contact rating of the relay switching points onto preferably under 10 mA, as higher switching current lead to an increased local warming and thus to a massive error at the reference junction measurement. • If the variations during operation are permanent and constant, the reference junction measurement can be corrected via the offset.

