

Limit Alarm Unit DG 35200

Monitoring of analog standard signals

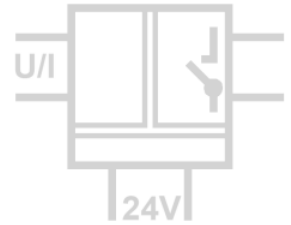

The configurable Limit Alarm Switch DG 35200 is used for limit monitoring and processing of unipolar and bipolar standard signals. A SPST relay or optionally an isolated, passive transistor switch (Open-Collector) is available at the output.

The Limit Alarm Unit monitors standardized current and voltage signals, and transmits the signal to the switching output. A transmitter power supply is provided for the operation of 2-wire and 3-wire transmitters.

The configuration is carried out via DIP switch or USB interface. The switch point can be taught-in and corrected during operation with the front-side Teach-In buttons. The Alarm Unit has an adjustable switch-on delay, switch-off delay and a wiper function. Further settings such as memory function and window function can be programmed via USB interface.

The input is protected against polarity reversal and short circuit. The power supply can be provided via the connection terminal blocks or via the optional In-Rail-Bus. The switch status and the device status are indicated by LEDs on front panel. If the device is operated via the In-Rail-Bus, a common fault message is available on the status line.



- **Universal input for current and voltage**
and integrated transmitter supply
- **Easy configurable via DIP switches or via USB**
Limit point, hysteresis and mode of operation can be directly set, limit point adjust also in operation via teach-in function
- **Switchable timer and special functions**
Switch-on delay, switch-off delay and wiper function, Memory and window functions
- **3-Port-Separation**
Protection against switching errors due to parasitic voltages or ground loops
- **Extremely slim design**
6.2 mm slim housing for a simple and space saving DIN rail mounting
- **Optional In-Rail-Bus mounting rail connector**
allows for fast and economical installation
- **Protective Separation acc. to EN 61140**
Protects service personnel and downstream devices against impermissibly high voltage
- **5 Years Warranty**
Defects occurring within 5 years from delivery date shall be remedied free of charge at our plant (carriage and insurance paid by sender)



Prinzipschaltbild

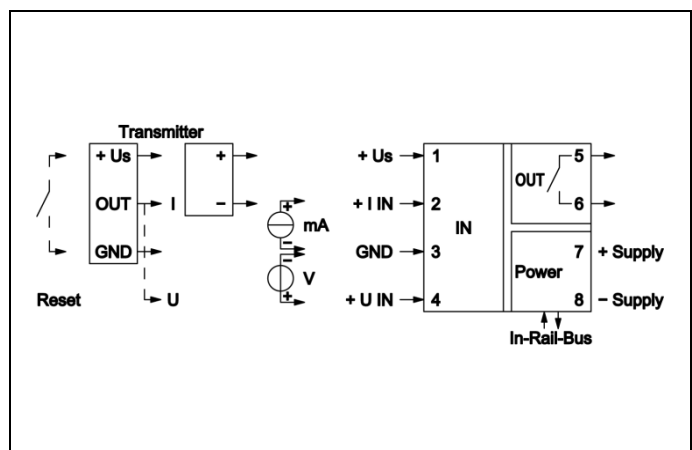



Technical Data

Input		Current		Voltage			
Input signal		0 to 20 mA	4 to 20 mA	± 20 mA	0 to 10 V	2 to 10 V	± 10 V
		0 to 10 mA	2 to 10 mA	± 10 mA	0 to 5 V	1 to 5 V	± 5 V
		ABS 20 mA			ABS 10 V		
		4 to 20 mA/NE43 (Relay inactive outside the NAMUR range 3.6 to 22 mA)					
Input resistance		≤ 20 Ω		≥ 1 MΩ			
Overload		< 50 mA		< 30 V			
Transmitter supply (Tx)		16 V (open circuit voltage/short circuit current < 22 V/35 mA)					
Output							
DG35200	Relay	250 V AC / 30 V DC / 2 A		Recommended minimum load 300 mW / 5 V / 5 mA			
DG35280	Transistor	36 V DC / 50 mA		galvanically isolated, not current limited			
Response time		≤ 20 ms					
Switching functions (selectable)		Make / break contact	ON delay, OFF delay or wiper: OFF, 0.5 s, 1 s, 5 s, 10 s				
Common fault message		Signal on In-Rail-Bus E (supply circuit) at device failure, cable break und short circuit					
General Data							
Test voltage		3 kV AC, 50 Hz, 1 Min.		Input against output against power supply/In-Rail-Bus			
Working voltage ¹⁾ (Basic Insulation)		600 V AC/DC for overvoltage category II and pollution degree 2 acc. to EN 61010-1					
Protection against electrical shock ¹⁾		Protective separation according to EN 61140 by reinforced insulation in accordance with EN 61010-1 up to 300 V AC/DC for overvoltage category II and pollution degree 2 between all circuits					
Ambient temperature		Operation: -25 °C to +70 °C (-13 to +158 °F)		Transport and storage: -40 °C to +85 °C (-40 to +185 °F)			
Power supply		24 V DC		voltage range 16.8 V to 31.2 V DC, max. 1.0 W			
EMV ²⁾		EN 61326-1					
Approvals (pending)		UL (USA/Canada) ATEX / IECEx		UL 61010, Class I, Div. 2 Zone 2 (nA)			
Construction		6.2 mm (0.244") housing, protection class IP 20, mounting on 35 mm DIN rail acc. to EN 60715					
Weight		Approx. 70 g					

1) For applications with high working voltages, ensure there is sufficient spacing or isolation from neighboring devices and protection against electric shocks.

2) Minor deviations possible during interference

Dimensions

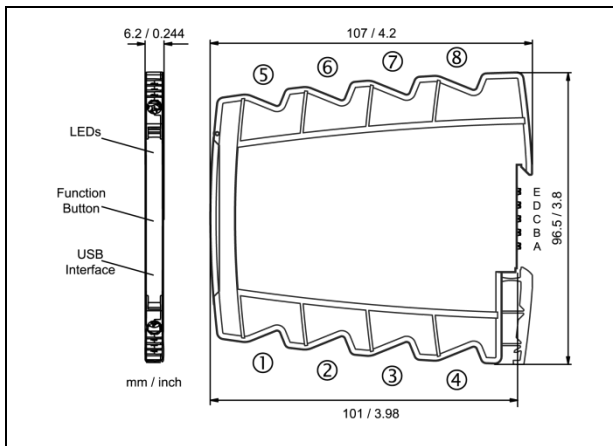

Subject to change!

Terminal assignments

1	+ Transmitter supply
2	+ Current input
3	- GND
4	+ Voltage input
5	≈ Relay + Transistor output
6	≈ Relay - Transistor output
7	+ Power supply (connected to In-Rail-Bus D)
8	- Power supply (connected to In-Rail-Bus C)

Connection

Captive plus-minus clamp screws
 Wire cross-section 0.5 to 2.5 mm² / AWG 20-14
 Stripped length 8 mm / 0.3 in
 Screw terminal torque 0.6 Nm / 5 lbf in
 Optional power connection via In-Rail-Bus (see accessories)

Product line

Device	Order No.	Relay	Transistor
Limit Alarm Unit, configurable		DG 35200 S	DG 35280 S
Limit Alarm Unit, configurable, In-Rail-Bus for power supply and status message		DG 35200 B	DG 35280 B