

4 Channel DI/DO Module DMB 96700

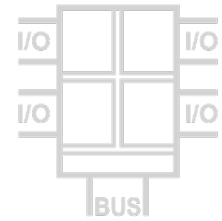

4 independent controllable digital I/O channels, Modbus RTU

The Modbus 4-channel DI/DO module provides four independently configurable inputs/outputs. The inputs can be used either as a binary, frequency or counter input with three selectable input levels. The open collector outputs are usable as binary, frequency, pulse or PWM outputs. Various time functions can be used to set the switching behaviour.

All parameters can be set via the Modbus RTU interface and via a programming socket behind the front panel. A free PC configuration software also offers extended setting options and extensive diagnostic functions during operation. A subset of the most common settings is also available via DIP switches.

The 5 port isolation ensures reliable decoupling of the inputs/outputs from each other and from the processing circuit and the power supply. Power supply and Modbus RTU are connected via the rear-mounted In-Rail-Bus connection (see Accessories).

- **4 independent controllable Channels**
programmable as digital input or output
- **Extensive programmable operating functions**
programmable switch-ON and switch-OFF behavior
- **Protective 5 port separation up to 300 V AC/DC**
test voltage 3 kV
- **Status indication**
indication of operation status for each I/O channel
- **In-Rail-Bus Connector for Modbus and Power Supply**
allows fast and economical installation
- **Freely scalable**
up to 247 DRAGO modules in one Modbus segment
- **Extremely slim design**
6.2 mm slim housing for a simple and space saving DIN rail mounting
- **5 Years Warranty**
Defects occurring within 5 years from delivery date shall be remedied free of charge at our plant (carriage and insurance paid by sender)



Block diagram

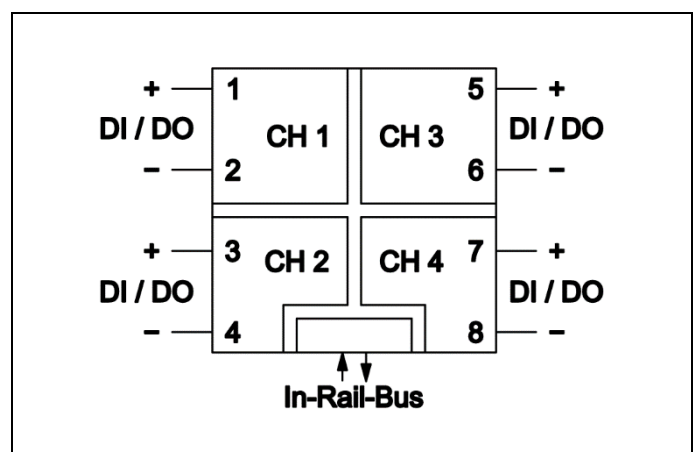



Technical Data

Input		
Input level	5 V, 12 V, 24 V	Input resistance: 4 k Ω
Input voltage	< 32 V DC	
Functions	Binary Frequency: 0.1 Hz to 1 kHz Counter: 16 / 32 Bit	Min. pulse width: 0.5 ms
Output		
Output type	Open collector	
Max. voltage / current	32 V DC, 100 mA	
Residual voltage	< 1.5 V DC	
Functions	Binary Frequency: 0.1 Hz to 1 kHz Pulse: 1 to 60000 /min PWM: 10 to 90 %	Min. pulse width: min. 0.3 ms , programmable Basic frequency: 500 Hz
Modbus		
Protocol	Modbus RTU (RS485)	
Module addressing	1 to 247	
Baud rate	300, 600, 1200, 2400, 4800, 9600, 19200, 38400, 57600, 115200	
Configuration	Parity: Even, Odd, None 2 stop bits, None 1 stop bit	Response delay: 1 to 1000 ms
Connectivity	Up to 247 DRAGO Modbus devices without additional repeater (1/8 Load)	
General Data		
Indication	Yellow LED for each channel on front panel	
Test voltage	3 kV AC, 50 Hz, 1 min. All channels against each other and against Modbus/power supply	
Protection against dangerous body currents ¹⁾	Protective Separation by reinforced insulation acc. to DIN EN 61010-1 up to 300 V AC/DC for overvoltage category II and contamination class 2 between input and Modbus/power supply	
Ambient temperature	Operation: -25 °C to +70 °C (-13 to +158 °F) Transport and storage: -40 °C to +85 °C (-40 to +185 °F)	
Power supply	24 V DC voltage range 16.8 V to 31.2 V DC, max. 0.5 W	
EMC ²⁾	EN 61326-1	
Construction	6.2 mm (0.244") housing, protection type: IP 20, mounting on 35 mm DIN rail acc. to EN 60715	
Weight	Approx. 70 g	

1) For applications with high working voltages, ensure there is sufficient spacing or isolation from neighboring devices and protection against electric shocks.
2) Minor deviations possible during interference

Dimensions

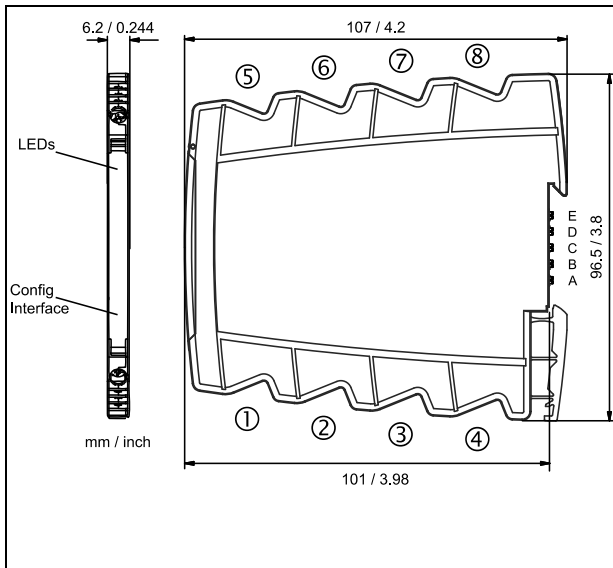

Terminal assignments

1	+ Channel 1
2	- Channel 1
3	+ Channel 2
4	- Channel 2
5	+ Channel 3
6	- Channel 3
7	+ Channel 4
8	- Channel 4
A	Modbus A
B	Modbus B
C	- Power supply
D	+ Power supply

Connection

Captive plus-minus clamp screws
Wire cross-section 0.5 ... 2.5 mm² / AWG 20-14
Stripped length 8 mm / 0.3 in
Screw terminal torque 0.6 Nm / 5 lbf in
Optional power connection via In-Rail-Bus (see accessories)

Subject to change!

Product line

Device	Order No.
Modbus 4 Channel DI/DO Module	DMB 96700 B