

# 4 Channel Relay Module DMB 96800

4 independent power relays, Modbus RTU

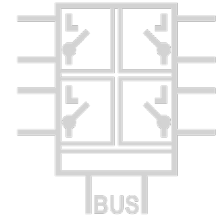

The Modbus 4-channel relay module can be used to switch four electrically isolated relays via a Modbus interface. Various time functions can be used to influence the switching behavior.

All parameters can be set via the Modbus RTU interface and via a programming socket behind the front panel. A free PC configuration software also offers extended setting options and extensive diagnostic functions during operation. A subset of the most common settings is also available via DIP switches.

The 5 port isolation guarantees reliable decoupling of the outputs from each other and from the processing circuit and the auxiliary power circuit. Power supply and Modbus RTU are connected via the rear-mounted In-Rail-Bus connection (see Accessories).

- **4 independent power relays**  
 250 V AC / 30 V DC / 2 A
- **Extensive programmable operating functions**  
 programmable switch-ON and switch-OFF behavior
- **Protective 5-way separation up to 300 V AC/DC**  
 Test voltage 3 kV
- **Status indication**  
 indication of operation status for each relay
- **In-Rail-Bus Connector for Modbus and Power Supply**  
 allows fast and economical installation
- **Freely scalable**  
 up to 247 DRAGO modules in one Modbus segment
- **Extremely slim design**  
 6.2 mm slim housing for a simple and space saving DIN rail mounting
- **5 Years Warranty**  
 Defects occurring within 5 years from delivery date shall be remedied free of charge at our plant (carriage and insurance paid by sender)



Block diagram

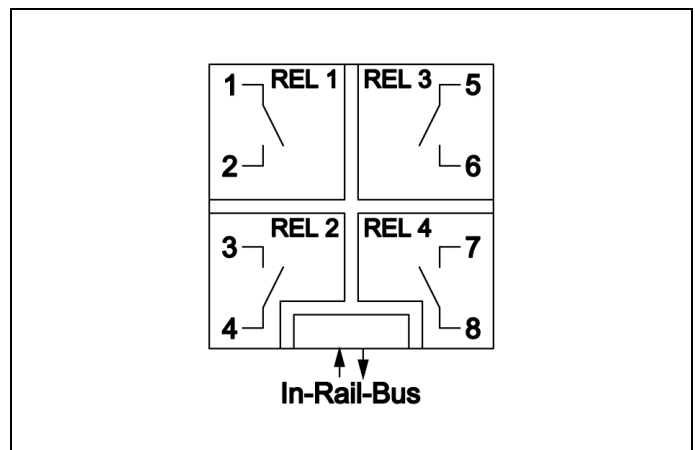

**6mm**

## Technical Data

Output	
Relay 1, 2, 3, 4	250 V AC / 30 V DC / 2 A
Indication	Yellow LED for each channel on front panel
Modbus	
Protocol	Modbus RTU (RS485)
Module addressing	1 to 247
Response delay	1 to 1000 ms
Baud rate	300, 600, 1200, 2400, 4800, 9600, 19200, 38400, 57600, 115200
Configuration	Parity: Even, Odd, None 2 stop bits, None 1 stop bit
Connectivity	Up to 247 DRAGO Modbus devices without additional repeater (1/8 Load)
Indication	Yellow LED on front panel
General Data	
Test voltage	3 kV AC, 50 Hz, 1 Min. All relays against each other and against Modbus/power supply
Protection against dangerous body currents <sup>1)</sup>	Protective Separation by reinforced insulation acc. to DIN EN 61010-1 up to 300 V AC/DC for overvoltage category II and contamination class 2 between input and Modbus/power supply
Ambient temperature	Operation: -25 °C to +70 °C (-13 to +158 °F) Transport and storage: -40 °C to +85 °C (-40 to +185 °F)
Power supply	24 V DC Voltage range 16.8 V to 31.2 V DC, max. 0.7 W
EMC <sup>2)</sup>	EN 61326-1
Construction	6.2 mm (0.244") housing, protection type: IP 20, mounting on 35 mm DIN rail acc. to EN 60715
Weight	Approx. 70 g

1) For applications with high working voltages, ensure there is sufficient spacing or isolation from neighboring devices and protection against electric shocks.

2) Minor deviations possible during interference

### Dimensions

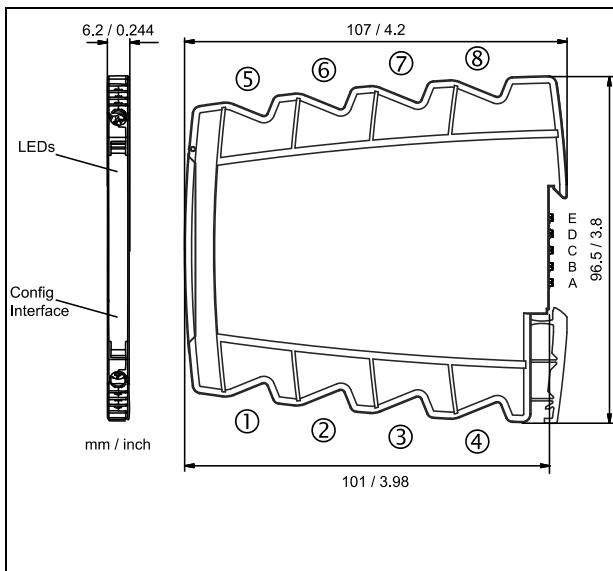

Subject to change!

### Terminal assignments

1	Relay 1
2	Relay 1
3	Relay 2
4	Relay 2
5	Relay 3
6	Relay 3
7	Relay 4
8	Relay 4
A	Modbus A
B	Modbus B
C	- Power supply
D	+ Power supply

### Connection

Captive plus-minus clamp screws  
 Wire cross-section 0.5 ... 2.5 mm<sup>2</sup> / AWG 20-14  
 Stripped length 8 mm / 0.3 in  
 Screw terminal torque 0.6 Nm / 5 lbf in  
 Optional power connection via In-Rail-Bus (see accessories)

### Product line

Device	Order No.
Modbus 4 Channel Relay Module	DMB 96800 B