

Pt Temperature Transmitter DT 45200

Temperature Measuring with Pt Sensors,
 configurable via DIP Switch or USB

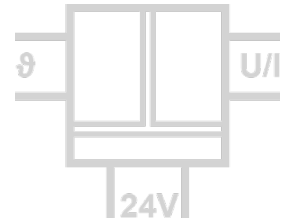

The Pt Temperature Transmitter DT 45200 is used for measure industrial process signals. It converts Pt sensor signals to isolated standard signals.

Due to the easy setting of the calibrated measuring ranges via DIP switch the Transmitter is suitable for flexible use.

With the USB Programming-Kit DRAGOset the Transmitter can be configured and all data can be stored by a PC. In mode of programming no additionally auxiliary power is required.

The Commissioning Function, switchable on front panel, generates an output reference signal for testing and adjusting of the downstream signal path.

The auxiliary power can be supplied via the connection terminals or via the optional In-Rail-Bus connector. The status of power supply and sensor connection will be displayed by a LED on front.



- **Measuring input for all Pt temperature sensors**
 more than 1200 standard ranges ready to use
- **Easy configurable via DIP switches**
 or via USB interface without auxiliary power supply
- **Switchable service functions**
 for an easy commissioning
- **3-port isolation**
 Protection against erroneous measurements due to parasitic voltages or ground loops
- **Extremely slim design**
 6.2 mm slim housing for a simple and space saving DIN rail mounting
- **Optional In-Rail-Bus mounting rail connector**
 allows for fast and economical installation
- **Protective Separation acc. to EN 61140**
 Protects service personnel and downstream devices against impermissibly high voltage
- **5 Years Warranty**
 Defects occurring within 5 years from delivery date shall be remedied free of charge at our plant (carriage and insurance paid by sender)



Block Diagram

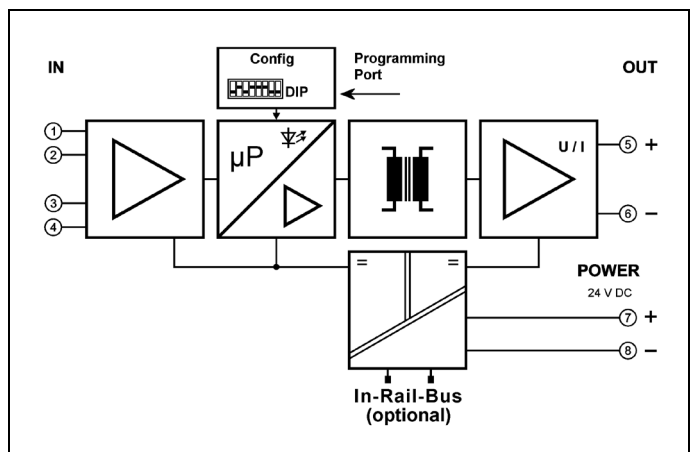



Technical Data

Input	
Sensor	Pt100, Pt200, Pt500, Pt1000, Pt2000 acc. IEC 60751 JPt50, JPt100 (TK3916) acc. JIS C 1604
Measuring range	-200 to +850 °C in calibrated steps of 25 °C, configurable via DIP switch or USB interface
Measuring span min.	25 K
Measuring error	< 0.1 K + 0,05 % meas. val.
Sensor connection	4-wire, 3-wire, 2-wire
Sensor current	0.2 mA
Cable resistance	< 100 Ω per wire at 4-wire and 3-wire connection
Output	
	Current Voltage
Output signal	0 ... 20 mA 4 ... 20 mA 0 ... 5 V 0 ... 10 V
Load	≤ 12 V (600 Ω at 20 mA) ≤ 5 mA (2 kΩ at 10 V)
Residual ripple	< 10 mV _{rms}
Transfer range	0 to 102.5 % (3.8 to 20.5 mA at output 4 to 20 mA) Transfer characteristic rising / falling
Error signal	Sensor/wire break, Error signal programmable
General data	
Transmission error	< 0.1 % full scale
Temperature coefficient ¹⁾	< 100 ppm/K
Sampling rate / Response time T ₉₉	4/s / 250 ms
Test voltage	3 kV AC, 50 Hz, 1 min. Input against output against power supply
Working voltage ²⁾ (basic insulation)	600 V AC/DC for overvoltage category II and pollution degree 2 acc. to EN 61010-1
Protection against electric shocks ²⁾	Protective Separation by reinforced insulation acc. to EN 61010-1 up to 300 V AC/DC for overvoltage category II and contamination class 2 between input and output and power supply
Ambient temperature	Operation -25 °C to +70 °C (-13 to +158 °F) Transport and storage -40 °C to +85 °C (-40 to +185 °F)
Power supply	24 V DC voltage range 9.6 V to 31.2 V DC, approx. 0.8 W
EMC ³⁾	EN 61326-1
Approvals	ATEX DEMKO 16 ATEX 1685X Ex II 3 G Ex nA IIC T4 Gc IECEX IECEX UL 16.0055X Ex nA IIC T4 Gc UL E478692 USA/Canada Class I, Division 2 Groups A, B, C, D T4
Construction	6.2 mm (0.244") housing, protection class IP 20, mounting on 35 mm DIN rail acc. to EN 60715
Weight	Approx. 70 g

1) Average TC related to full scale value in specified operating temperature range, reference temperature 23 °C

2) For applications with high working voltages, ensure there is sufficient spacing or isolation from neighboring devices and protection against electric shocks.

3) Minor deviations possible during interference

Dimensions

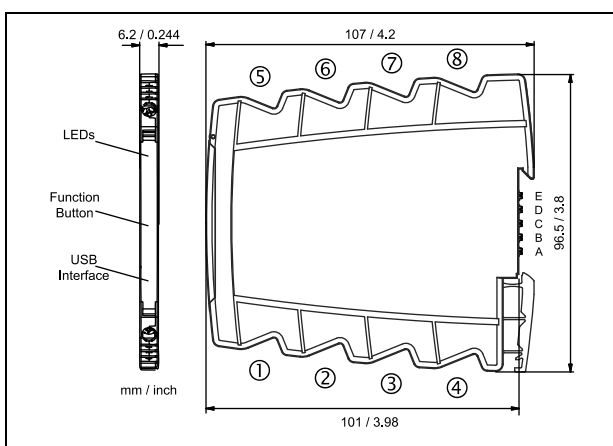

Subject to change!

Terminal assignments

1	+ Input Pt
2	+ Input 3/4-Leiter
3	- Input 4-Leiter
4	- Input Pt
5	+ Output
6	- Output
7	+ Power supply (connected to In-Rail-Bus D)
8	- Power supply (connected to In-Rail-Bus C)

Connection

Captive plus-minus clamp screws
Wire cross-section 0.5 ... 2.5 mm² / AWG 20-14
Stripped length 8 mm / 0.3 in
Screw terminal torque 0.6 Nm / 5 lbf in
Optional power connection via In-Rail-Bus (see accessories)

Product line

Device	Order No.
Pt Temperature Transmitter, configurable via DIP switch and USB	DT 45200 S
Pt Temperature Transmitter, configurable via DIP switch and USB, In-Rail-Bus for power supply	DT 45200 B