

Instrumentation Products

Gauge Valves and Pressure Gauge Accessories



Introduction

Introduction

The AS-Schneider Group with its headquarters in Germany is one of the World's Leading Manufacturers of Instrumentation Valves and Manifolds. AS-Schneider offers a large variety of Gauge Valves, Gauge Cocks, Syphons and Supports as well as Gauge Protectors, Gauge Snubbers and Accessories needed for the instrumentation installations globally.

Selection can be made from a comprehensive range of bodies with a variety of connections and material options, optimising installation and access opportunities. Many of the valves shown in this catalogue are available from stock or within a short period of time. The dimensions shown in this catalogue apply to standard types. If you need the dimensions for your individual type please contact the factory.

Continuous product development may from time to time necessitate changes in the details contained in this catalogue. AS-Schneider reserves the right to make such changes at their discretion and without prior notice.

All dimensions shown in this catalogue are approximate and subject to change.



Introduction	page 2
Contents	page 3
General Features and Connections	page 4-5
Gauge Valves	page 6-14
Gauge Cocks	page 15-18
Gauge Protectors	page 19-21
Gauge Snubbers	page 22-23
Supports for Valves and Measuring Instruments	page 24
Syphons, Elbows and Straight Pipes	page 25-31
Pressure Gauge Accessories	page 32-35

General Features

Body Material Options

Material Group	AS Material Designation	Material No.	Short Name	Equivalent UNS-No.	Material Grade acc. to ASTM	Gauge Valves	Gauge Cocks	Gauge Protectors	Gauge Snubbers	Syphons
Copper Alloys	Brass*	CW614N	CuZn39Pb3			S	S	S	S	
		CW617N	CuZn40Pb2			S	S	S	S	
Heat Resistant Unalloyed Steel	Carbon Steel	1.0038	S235JRG2						S	
		1.0460	P250GH			S				
		1.0345	P235GH							S
Austenitic Stainless Steel	Stainless Steel	1.4571	X6CrNiMoTi17-12-2	S31635	316Ti	S	S	S	S	S
		316 quadruple certified**	1.4401	X5CrNiMo17-12-2	S31600	316	A		S	S
		1.4404	X2CrNiMo17-12-2	S31603	316L	A		S	S	O
	6Mo	1.4547	X1CrNiMoCuN20-18-7	S31254		A		O	O	
Austenitic-Ferritic Stainless Steel	Duplex	1.4462	X2CrNiMoN22-5-3	S31803	F51	A		S	S	
		1.4410	X2CrNiMoN25-7-4	S32750	F53	A		O	O	
	Superduplex	1.4501	X2CrNiMoCuWN25-7-4	S32760	F55	A		O	O	
Nickel Based Alloys	Alloy 400	2.4360	NiCu30Fe	N04400		A		S	S	O
	Alloy C-276	2.4819	NiMo 16 Cr 15 W	N10276		A		S	S	O
	Alloy 625	2.4856	NiCr22Mo9Nb	N06625		A		S	S	O
Titanium	Titanium Grade 2	3.7035	Ti-II	R50400		A		O	O	

* Brass: Body made of either CW 614N or CW 617N

S = Standard | O = Optional | A = Alternative (see Catalogue AS-2601)

**Quadruple certified means 316 / 316L / 1.4401 / 1.4404

Standard Features

Every standard valve is factory tested hydrostatically to a requirement of no visible leakage.

Brass, carbon steel or stainless steel valve bodies are forged, except gauge snubbers in carbon steel and stainless steel. All other components are made from barstock material – syphons also made from pipe.

Certification acc. to EN 10204 2.1, 2.2, 3.1 and 3.2!

Valves for sour gas service are available in accordance with NACE MR0175/MR0103 and ISO 15156. To order, contact the factory. Some of our valves are supplied according to NACE as standard.

Surface treatment of carbon steel valves and accessories: Phosphatized, Galvanized surface optional.

Optional Features

- Valves and Accessories cleaned and lubricated for Oxygen Service Suffix used F0 and F5.
- Valves according to DVGW.
- Valves for Fugitive Emission Applications.

If you don't find your options in this catalogue, please contact the factory.

Continuous product development may from time to time necessitate changes in the details contained in this catalogue. AS-Schneider reserves the right to make such changes at their discretion and without prior notification. All dimensions shown in this catalogue are approximate and subject to change.

Connections

AS-Schneider is manufacturing a lot of different connections and connection combinations. In this catalogue we are showing the most popular types. On this page you will find the standard connections in detail.

Parallel Pipe Threads

BSP Parallel Male Threads
acc. to EN 837-1 (e.g. G 1/2)

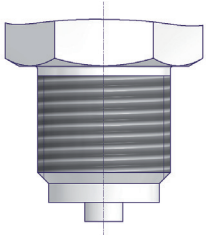

Adjusting Nut acc. to DIN 16283
(LH x RH)

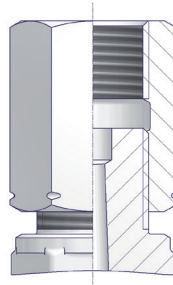

Swivel Nut (Welded Nipple Design)
acc. to DIN 16284

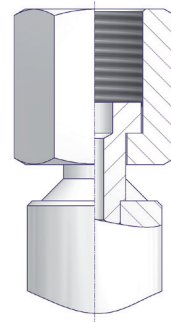

Tube Fittings

Single Ferrule Tube Fittings
acc. to EN ISO 8434-1 Size S

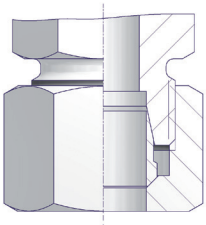

Tapered Pipe Threads

NPT Male Threads acc. to
ASME B 1.20.1

BSP Tapered Thread acc. to
ISO 7/1 (e.g. R 1/2)

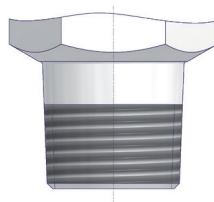

NPT Female Threads acc. to
ASME B 1.20.1

BSP Tapered Thread acc. to ISO 7/1
(e.g. Rc 1/2)

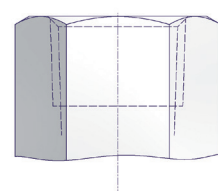

Test Connections

M 20 x 1.5 Male Thread with sealing cap
acc. to DIN 16271 or with protective
cap acc. to DIN 16272 and DIN 16263
(protective cap not shown)

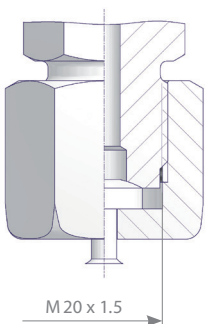

Test Flange $\varnothing 40 \times 5$

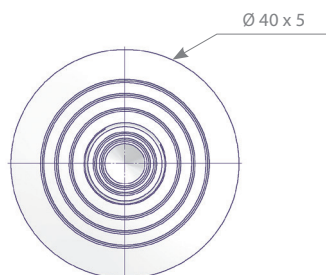

Test Flange 60 x 25 x 10

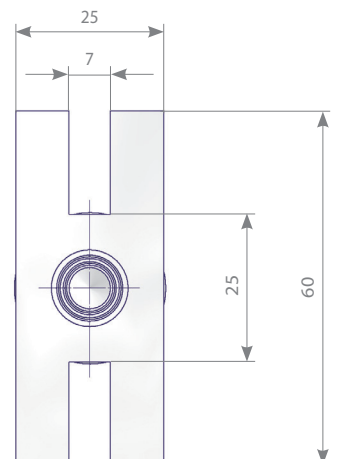

Gauge Valves | Features and Benefits

Product Description

AS-Schneider Gauge Valves are designed, manufactured and tested according to DIN 16270, DIN 16271 and DIN 16272. According to these standards the valves are applicable for a max. allowable (Working) Pressure (PS) of 250 bar (brass) respectively 400 bar (carbon steel and stainless steel) and a max. allowable Temperature (TS) of 120°C for liquids, gas or vapors.

The max. allowable Temperature (TS) of 120°C is considering the requirement that valves and measuring instruments need to be protected against heating by hot media. This can be achieved by syphons or by instrument impulse lines with sufficient length. However the AS-Schneider valves can be used for temperatures up to 300°C - PTFE up to 232°C, Graphite up to 300°C, except the brass types (limited to 200°C).

Standard Features

- Forged Body
- Internal Stem Thread
- Stem with cold rolled surface and Non-Rotating Needle Tip
- PTFE Standard Packing

Pressure Test:

A shell test and a seat test are performed at 1.5 times the max. allowable (working) pressure acc. to EN 12266-1 – P10, P11 and P12.

Optional Features

DVGW approved Valves:

AS-Schneider is offering different valve types which have been tested and approved by DVGW. The test basis is DVGW VP 308. The valves are applicable for all gases in accordance with DVGW G 260.

Pressure-Temperature Rating:

- Max. 100 bar @ -5°C up to +60°C
- DVGW-Approval-No.: DG-4315BQ0226

Fugitive Emission Applications:

For Fugitive Emission Applications AS-Schneider is providing bellows sealed valves. Choice of Pressure class PN 100 or PN 250. Valve head unit in stainless steel, wetted parts 1.4571, needle tip Stellite. Optional available are TA-Luft and ISO 15848 solutions. For more details please contact the factory.

Certification:

Inspection certificate 3.1 acc. to EN 10 204 for valve body material and pressure test available on request.

Oxygen Service:

AS-Schneider offers an option with Reinforced PTFE Packing cleaned and lubricated for Oxygen Service – Suffix F5:

Pressure-Temperature Rating:

- Max. 420 bar @ 60°C
- Max. 200°C @ 90 bar

Sealing Washers according to EN 837-1, see Page 34.



Packing adjustment may be required during the service life of the valves.



Valves that have not been cycled for a period of time may have a higher initial actuation torque.

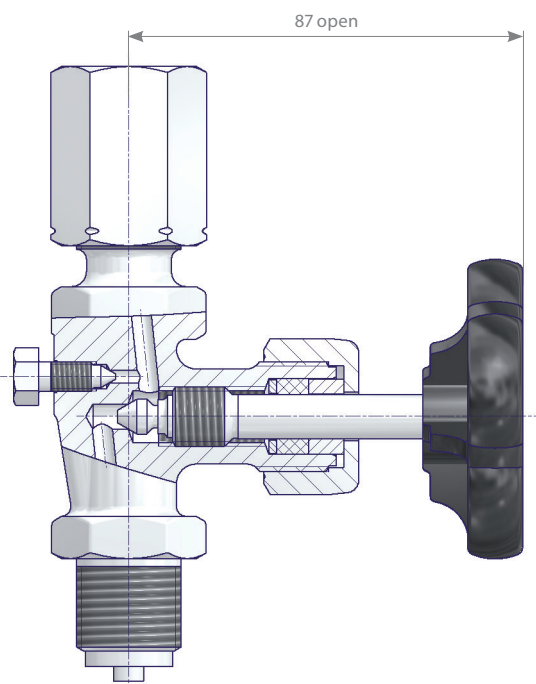

Components	Brass	Carbon Steel	Stainless Steel
Material / Material No.			
Body	Brass	1.0460	1.4571
Valve Stem	1.4104		
Needle Tip	1.4104		1.4571
Packing	PTFE (Optional Graphite)		
Union Nut	Unalloyed Steel		Stainless Steel
Adjusting Nut	Unalloyed Steel		
Swivel Nut	Brass	Unalloyed Steel	1.4571
Bleed Screw	A4 (316)		
Test Flange	Brass	Unalloyed Steel	1.4571
Sealing Cap	Unalloyed Steel		Stainless Steel
Handwheel	Plastic		

DVGW approved Gauge Valve

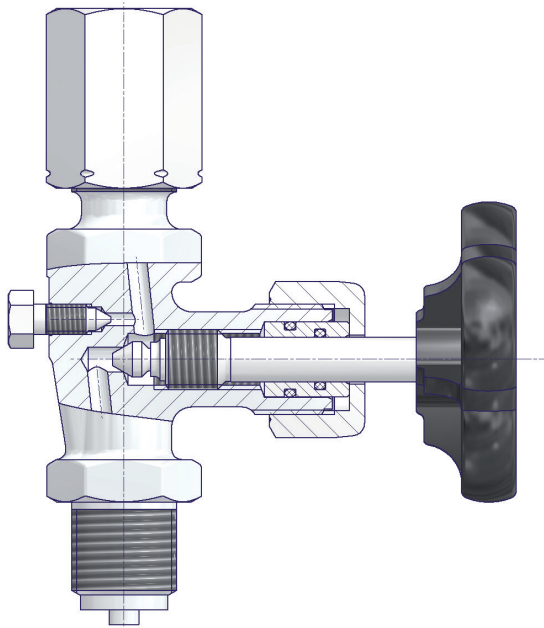

Components	Brass	Carbon Steel	Stainless Steel
Material / Material No.			
Body	Brass	1.0460	1.4571
Valve Stem	1.4104		
Needle Tip			
O-Rings	FKM (FPM by ISO)		
O-Ring Retainer	Brass		1.4571
Union Nut	Unalloyed Steel, galvanized		Stainless Steel
Adjusting Nut	Brass	Unalloyed Steel	
Swivel Nut			1.4571
Bleed Screw	A4 (316)		
Test Flange	Brass	Unalloyed Steel	1.4571
Sealing Cap	Unalloyed Steel, galvanized		Stainless Steel
Handwheel	Plastic		

Bellows Sealed Gauge Valve

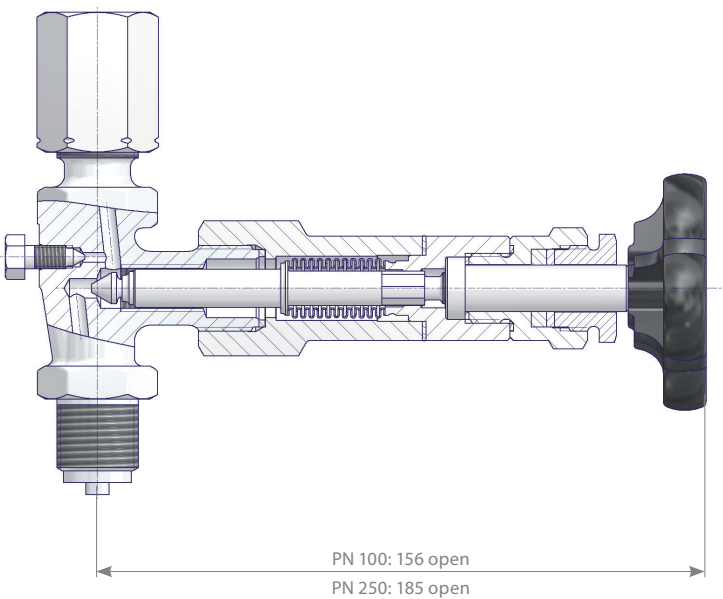

Components	Carbon Steel	Stainless Steel
Material / Material No.		
Body	1.0460	1.4571
Bonnet	1.4571	
Bellow		
Valve Stem		
Needle Tip	Stellite	1.4571
Packing	Graphite	
Stem Nut	1.4122	
Adjusting Nut	Unalloyed Steel	Stainless Steel
Swivel Nut		1.4571
Bleed Screw	A4 (316)	
Test Flange	Unalloyed Steel	1.4571
Sealing Cap		Stainless Steel
Handwheel	Plastic	

Gauge Valves without Test Connection

Instrument Connection - Adjusting Nut

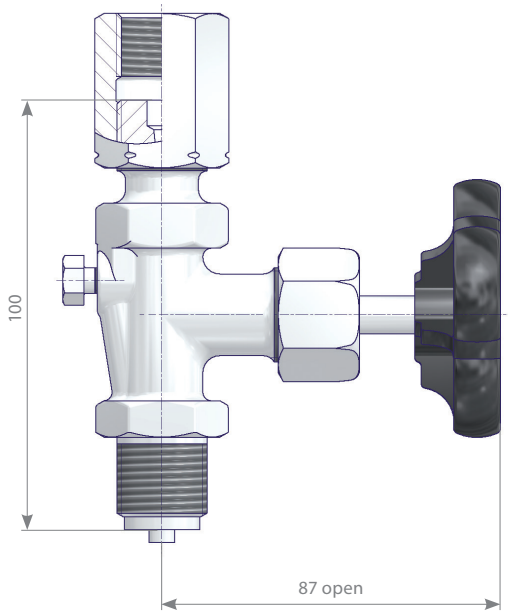

Inlet	Outlet	Material	References	Part Number
G 1/2 Male	G 1/2 Adjusting Nut	Brass	DIN 16270 Type A	S004.16.000
			DVGW approved	S004.26.000
		Brass (AP)*	DIN 16270 Type A	S004.16.000.32
			1.0460	DIN 16270 Type A
		DVGW approved		S004.26.100
		1.4571	DIN 16270 Type A	S004.16.200
DVGW approved	S004.26.200			
M 20 x 1.5 Male	M 20 x 1.5 Adjusting Nut	Brass		S004.16.050
		1.0460		S004.16.150
		1.4571		S004.16.250

* Brass (AP) = Body, Adjusting Nut and Union Nut in Brass

Instrument Connection - 1/2 NPT Female

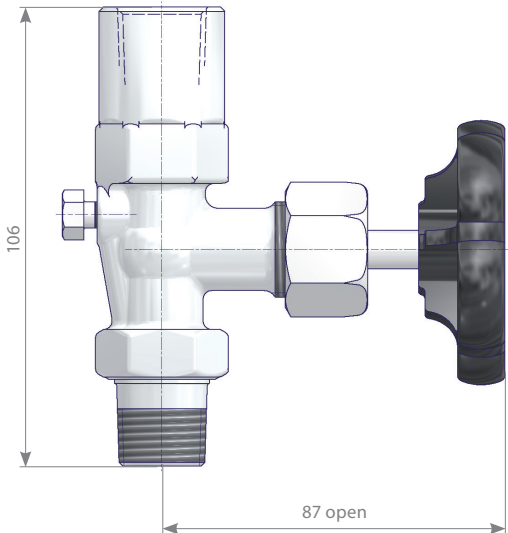

Inlet	Outlet	Material	References	Part Number
1/2 NPT Male	1/2 NPT Female	Brass		S004.16.083
		1.0460		S004.16.183
		1.4571		S004.16.283

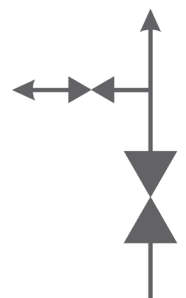

Gauge Valves without Test Connection

Instrument Connection - Swivel Nut and Shaft for Supports (see Page 24)

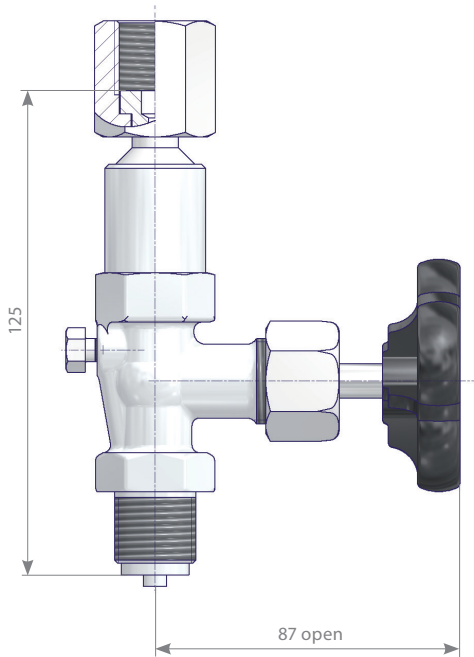

Inlet	Outlet	Material	References	Part Number
G 1/2 Male	G 1/2 Swivel Nut	Brass	DIN 16270 Type B	S004.16.020
			DVGW approved	S004.26.020
		1.0460	DIN 16270 Type B	S004.16.120
			DVGW approved	S004.26.120
		1.4571	DIN 16270 Type B	S004.16.220
			DVGW approved	S004.26.220

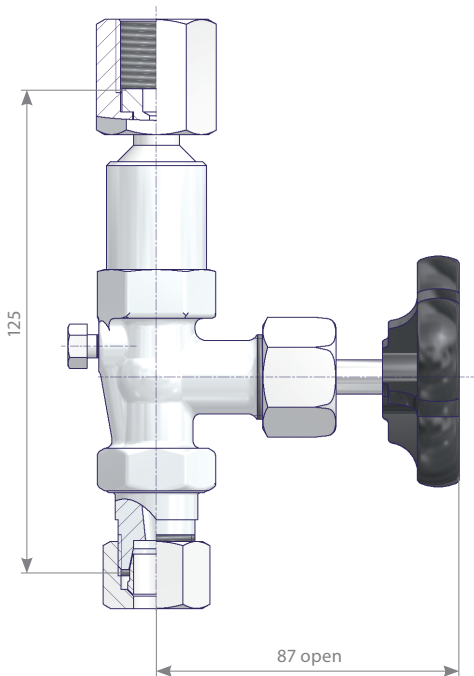

Inlet	Outlet	Material	References	Part Number
Tube Fitting Size 12S	G 1/2 Swivel Nut	Brass	DIN 16270 Type B	S004.16.020.13
			DVGW approved	S004.26.020.13
		1.0460	DIN 16270 Type B	S004.16.120.13
			DVGW approved	S004.26.120.13
		1.4571	DIN 16270 Type B	S004.16.220.13
			DVGW approved	S004.26.220.13

Gauge Valves with Test Connection

Instrument Connection - Adjusting Nut

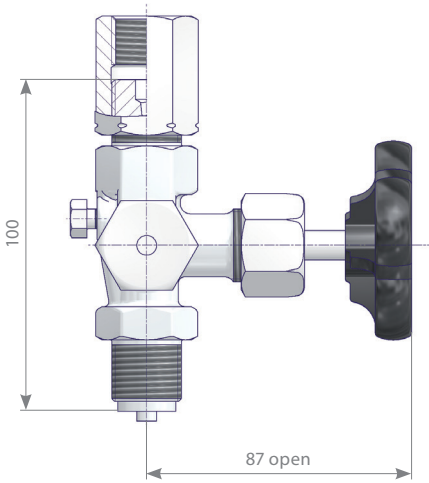

Valve with Test Connection M 20 x 1.5

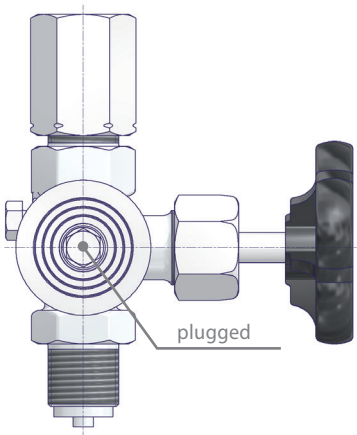

Valve with Test Flange $\varnothing 40 \times 5$

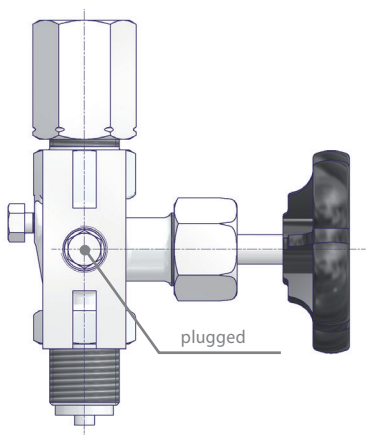

Valve with Test Flange 60 x 25 x 10

Inlet	Outlet	Test Connection	Material	References	Part Number
G 1/2 Male	G 1/2 Adjusting Nut	M 20 x 1.5 c/w Sealing Cap	Brass	DIN 16271 Type A	S004.17.000
				DVGW approved	S004.27.000
			Brass (AP)*	DIN 16271 Type A	S004.17.000.32
		Brass	Test Flange $\varnothing 40 \times 5$	S004.17.060	
			Test Flange 60 x 25 x 10	S004.17.070	
		1.0460	M 20 x 1.5 c/w Sealing Cap	DIN 16271 Type A	S004.17.100
				DVGW approved	S004.27.100
					S004.17.160
			Test Flange 60 x 25 x 10		S004.17.170
				M 20 x 1.5 c/w Sealing Cap	DIN 16271 Type A
DVGW approved	S004.27.200				
	S004.17.260				
1.4571	Test Flange $\varnothing 40 \times 5$		S004.17.270		
		M 20 x 1.5 c/w Sealing Cap	Brass	S004.17.050	
			1.0460	S004.17.150	
1.4571	S004.17.250				

* Brass (AP) = Body, Adjusting Nut, Sealing Cap and Union Nut in Brass

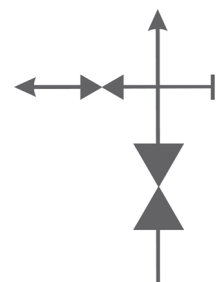

Gauge Valves with Test Connection

Instrument Connection - Swivel Nut and Shaft for Supports (see Page 24)

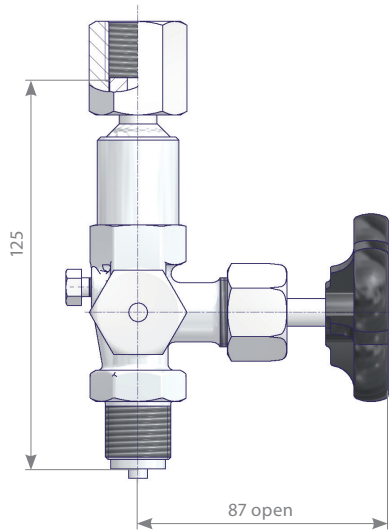

Inlet	Outlet	Test Connection	Material	References	Part Number
G 1/2 Male	G 1/2 Swivel Nut	M 20 x 1.5 c/w Sealing Cap	Brass	DIN 16271 Type B	S004.17.020
				DVGW approved	S004.27.020
			1.0460	DIN 16271 Type B	S004.17.120
				DVGW approved	S004.27.120
			1.4571	DIN 16271 Type B	S004.17.220
				DVGW approved	S004.27.220

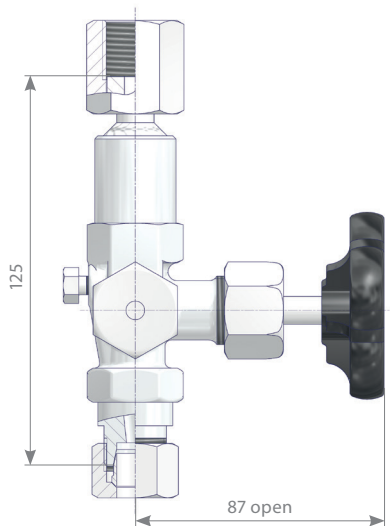

Inlet	Outlet	Test Connection	Material	References	Part Number
Tube Fitting Size 12S	G 1/2 Swivel Nut	M 20 x 1.5 c/w Sealing Cap	Brass	DIN 16271 Type B	S004.17.020.13
				DIN 16271 Type B	S004.17.120.13
			1.0460	DVGW approved	S004.27.120.13
				DIN 16271 Type B	S004.17.220.13
			1.4571	DVGW approved	S004.27.220.13

Instrument Connection - 1/2 NPT Female

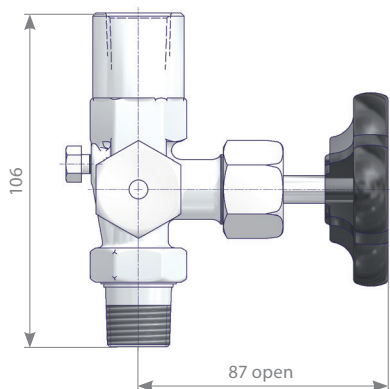

Inlet	Outlet	Test Connection	Material	References	Part Number
1/2 NPT Male	1/2 NPT Female	M 20 x 1.5 c/w Sealing Cap	1.0460		S004.17.135.02
			1.4571		S004.17.235.02

Block & Bleed Gauge Valves

Instrument Connection - Adjusting Nut

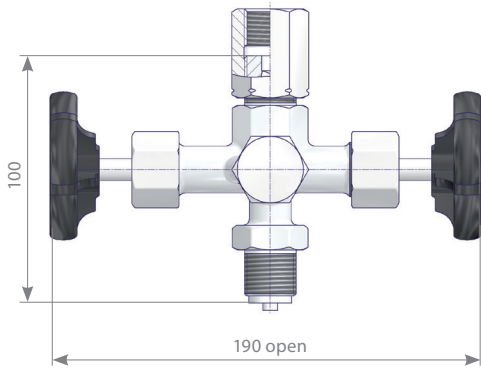

Valve with Test Connection M 20 x 1.5

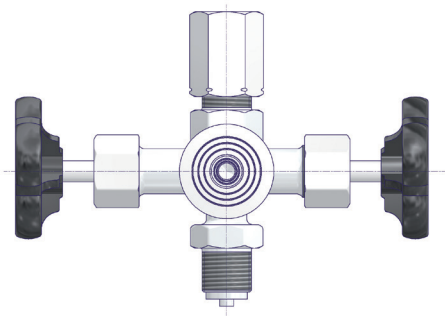

Valve with Test Flange $\varnothing 40 \times 5$

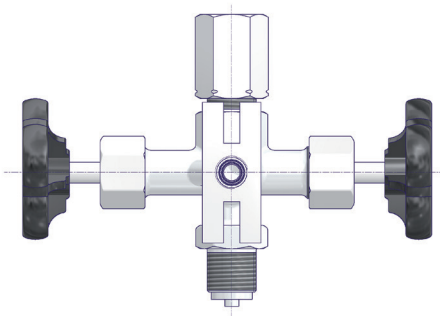

Valve with Test Flange 60 x 25 x 10

Inlet	Outlet	Test Connection	Material	References	Part Number		
G 1/2 Male	G 1/2 Adjusting Nut	M 20 x 1.5 c/w Protective Cap	Brass	DIN 16272 Type A	S004.60.000		
				DVGW approved	S004.80.000		
		Test Flange $\varnothing 40 \times 5$			S004.62.000		
				Test Flange 60 x 25 x 10			S004.61.000
				M 20 x 1.5 c/w Protective Cap	1.0460	DIN 16272 Type A	S004.60.100
						DVGW approved	S004.80.100
				Test Flange $\varnothing 40 \times 5$			S004.62.100
				Test Flange 60 x 25 x 10			S004.61.100
				M 20 x 1.5 c/w Protective Cap	1.4571	DIN 16272 Type A	S004.60.200
			DVGW approved	S004.80.200			
		Test Flange $\varnothing 40 \times 5$		S004.62.200			
		Test Flange 60 x 25 x 10			S004.61.200		
M 20 x 1.5 Male	M 20 x 1.5 Adjusting Nut	M 20 x 1.5 c/w Protective Cap	Brass		S004.60.050		
			1.0460		S004.60.150		
			1.4571		S004.60.250		

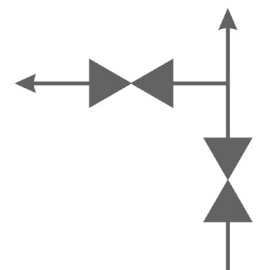

Instrument Connection - Swivel Nut and Shaft for Supports (see Page 24)

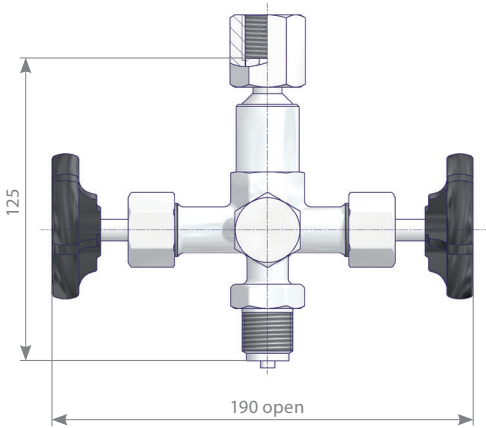

Inlet	Outlet	Test Connection	Material	References	Part Number
G 1/2 Male	G 1/2 Swivel Nut	M 20 x 1.5 c/w Protective Cap	Brass	DIN 16272 Type B	S004.60.020
				DVGW approved	S004.80.020
			1.0460	DIN 16272 Type B	S004.60.120
				DVGW approved	S004.80.120
			1.4571	DIN 16272 Type B	S004.60.220
				DVGW approved	S004.80.220

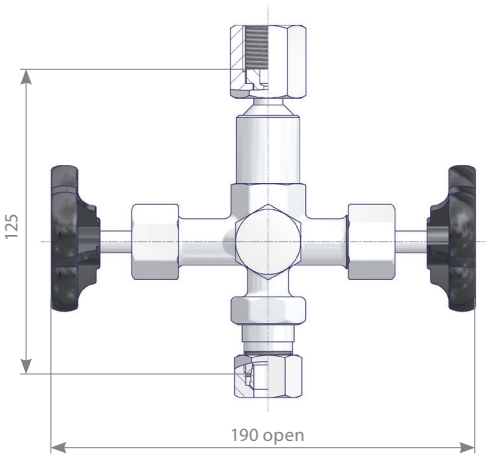

Inlet	Outlet	Test Connection	Material	References	Part Number
Tube Fitting Size 125	G 1/2 Swivel Nut	M 20 x 1.5 c/w Protective Cap	1.0460	DIN 16272 Type B	S004.60.120.13
				DVGW approved	S004.80.120.13
			1.4571	DIN 16272 Type B	S004.60.220.13
				DVGW approved	S004.80.220.13

Instrument Connection - 1/2 NPT Female

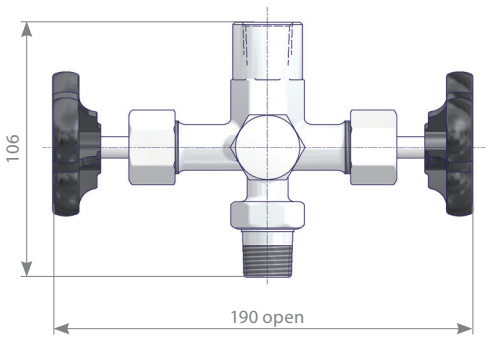

Inlet	Outlet	Test Connection	Material	References	Part Number
1/2 NPT Male	1/2 NPT Female	M 20 x 1.5 c/w Protective Cap	1.0460		S004.60.135.02
			1.4571		S004.60.235.02

Gauge Valves | Special Type G 1/4

Product Description

The size of the AS-Schneider Gauge Valves G 1/4 is smaller compared to the standard gauge valves, especially the brass type. Carbon steel and stainless steel components are identical to the standard gauge valves. The components of the brass type are smaller and the valve stem is a one-piece design. Pressure-Temperature Rating: Max. allowable (Working) Pressure PS of 125 bar (brass) respectively 250 bar (carbon steel and stainless steel) and a max. allowable Temperature (TS) of 200°C (brass type) respectively 232°C (carbon steel and stainless steel type) for liquids, gas or vapors.

Brass Design

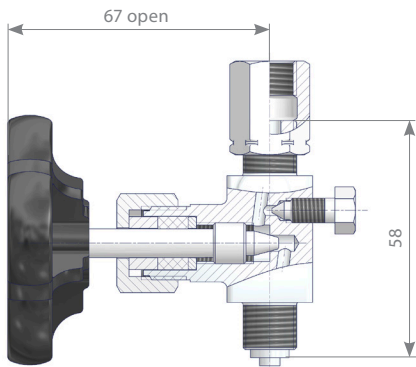

Carbon Steel and Stainless Steel Design

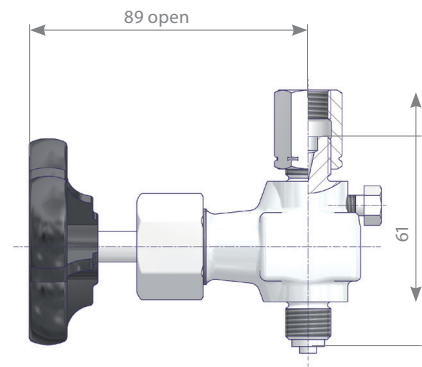

Inlet	Outlet	Test Connection	Material	Part Number
G 1/4 Male	G 1/4 Adjusting Nut		Brass	S004.12.000
		Test Flange Ø 40 x 5		S004.12.065
			1.0460	S004.13.130
			1.4571	S004.13.230

Components	Brass	Carbon Steel	Stainless Steel
Material / Material No.			
Body	Brass	1.0460	1.4571
Valve Stem		1.4104	
Needle Tip			
Packing	PTFE		
Union Nut	Brass	Unalloyed Steel	1.4571
Adjusting Nut			
Bleed Screw	A4 (316)		
Test Flange	Brass		
Handwheel	Plastic		

With Test Connection

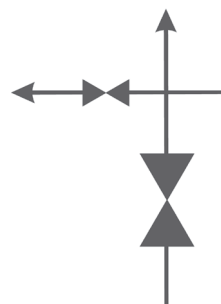

Without Test Connection

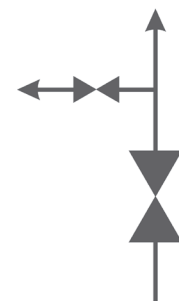

Gauge Cocks | Features and Benefits

Product Description

AS-Schneider Gauge Cocks are basically designed, manufactured and tested according to DIN 16261, DIN 16262 and DIN 16263. According to these standards the cocks are applicable for a max. allowable (Working) Pressure (PS) of 6 – 16 bar and a max. allowable Temperature (TS) of 50°C for liquids, gas or vapors. Originally our Gauge Cocks were designed for a max. allowable (Working) Pressure (PS) of 25 bar for the G 1/2 models. We kept this pressure class for these kind of gauge cocks, as you can see in the table on Page 16-18.

Standard Features

- Forged Body
- Plastic Handle

Pressure Test:

A seat test is performed at 1.5 times the max. allowable (working) pressure acc. to EN 12266-1 – P12, Leakage rate A.

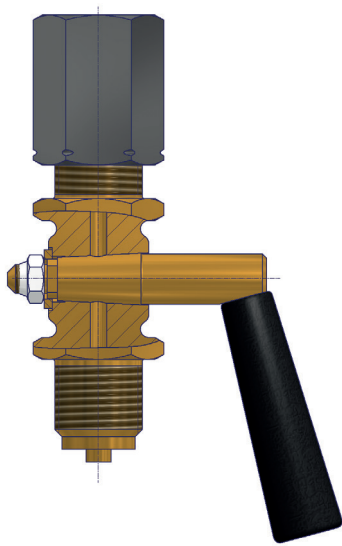

Optional Features

- Sealing Washers according to EN 837-1, see Page 34.

Components	Brass	Stainless Steel
Material / Material No.		
Body	Brass	1.4571
Plug		
Washer		1.4301
Hexagon Nut	Unalloyed Steel	A2
Union Nut	Brass	
Gland	Brass	
Packing	PTFE	
Adjusting Nut	Unalloyed Steel	Stainless Steel
Swivel Nut	Brass	
Test Flange		1.4571
Handle	Plastic	

Union Nut, Gland and Packing only applicable for Gauge Cocks with Gland.

Operating Positions

Operating Positions are marked on top of the plug. There are max. 4 positions available: Vent, Operate, Purge and Test. The Test Option is only available for Gauge Cocks with Test Connections. The other options are basically for all cocks available except for the Gauge Cocks with Gland without Vent / Test Connection, our types N003.09.000 and N003.10.000. These 2 models just have 2 Operating Positions: Operate or Closed (no marking on the plug required).

Before using the Operating Positions Vent or Purge you must be aware that system fluids are released to atmosphere. These fluids can be poisonous, irritating, hot or cold. This is also valid for the Test Position if the Test Pressure Gauge is not installed, respectively for Gauge Cocks without Test Connection because these Gauge Cocks are provided as a standard with a bleed outlet \varnothing 3.5 mm instead of the Test Connection. Operation and maintenance may only be done by experienced staff, which is familiar with the secure handling of the used media.

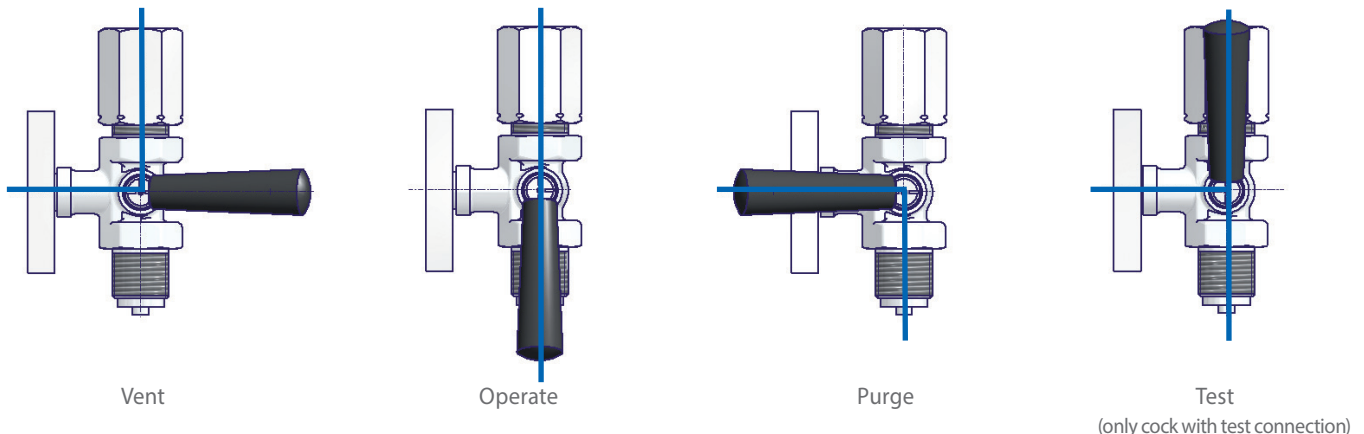

Gauge Cocks

Female x Female Connections

Gauge Cock with Test Flange Ø 40 x 5

Gauge Cock with Test Flange 60 x 25 x 10

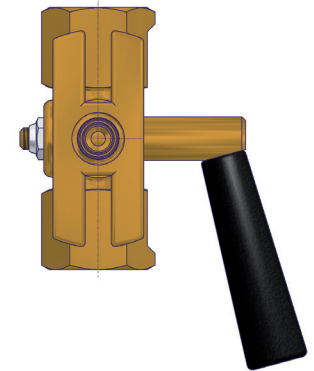
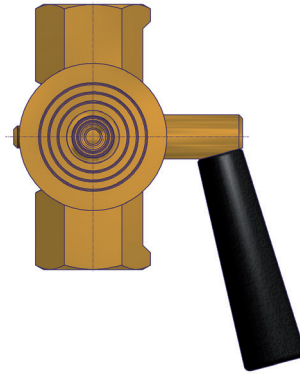
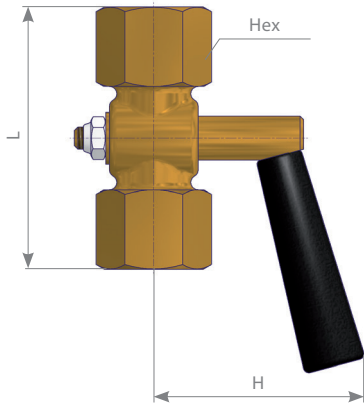

Inlet	Outlet	Material	PN	L	H	Hex	Test Connection	References	Part Number
G 1/4 Female	G 1/4 Female	Brass	6	48	30	17			S003.24.000
G 3/8 Female	G 3/8 Female		16	62	43	22			S003.58.000
G 1/2 Female	G 1/2 Female	1.4571	25	70	57	27		DIN 16261 Type A	S003.13.000
		Brass					Test Flange 60 x 25 x 10		S003.13.200
							Test Flange Ø 40 x 5	S003.16.000	
									S003.46.000

Male x Female Connections

Gauge Cock with Test Flange Ø 40 x 5

Gauge Cock with Test Flange 60 x 25 x 10

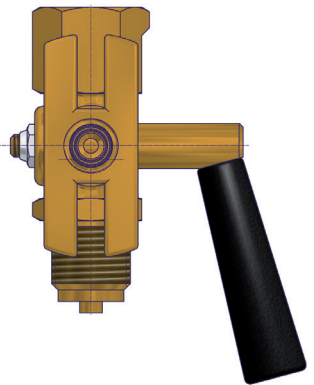
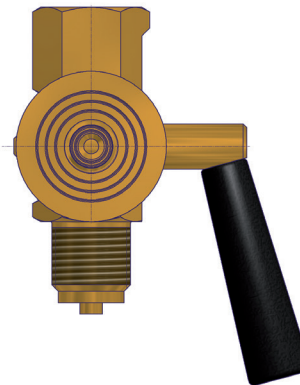
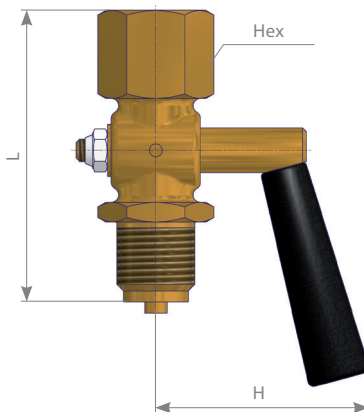

Inlet	Outlet	Material	PN	L	H	Hex	Test Connection	References	Part Number
G 1/4 Male	G 1/4 Female	Brass	6	51	30	17			S003.27.000
			25	70	57	27	Test Flange Ø 40 x 5		S003.47.030
G 3/8 Male	G 3/8 Female	Brass	16	60	43	22			S003.59.000
				74			Test Flange Ø 40 x 5		S003.47.020
G 1/2 Male	G 1/2 Female	1.4571	25	78,5	57	27		DIN 16261 Type B	S003.15.000
		83					S003.15.200		
		Brass		78,5			Test Flange 60 x 25 x 10	S003.17.000	
							Test Flange Ø 40 x 5		S003.47.000

Instrument Connection - Swivel Nut

Gauge Cock with Test Flange 60 x 25 x 10

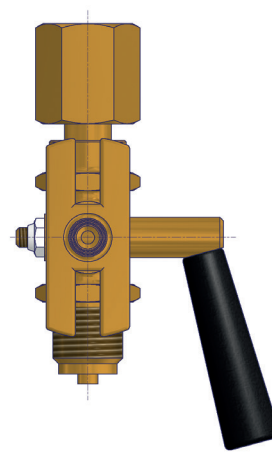
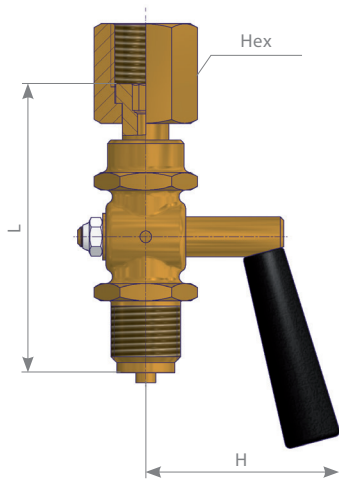

Inlet	Outlet	Material	PN	L	H	Hex	Test Connection	References	Part Number
G 1/2 Male	G 1/2 Swivel Nut	Brass	25	87	57	27			N003.19.000
				Test Flange 60 x 25 x 10				N003.14.000	
G 1/2 Female				82					S003.22.000
							Test Flange 60 x 25 x 10		S003.18.000

Gauge Cocks with Gland

Gauge Cock with Test Flange 60 x 25 x 10

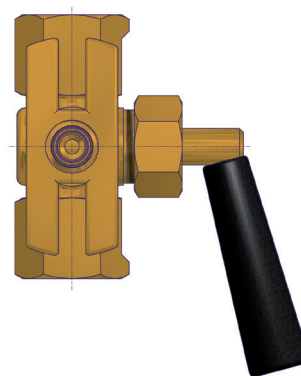
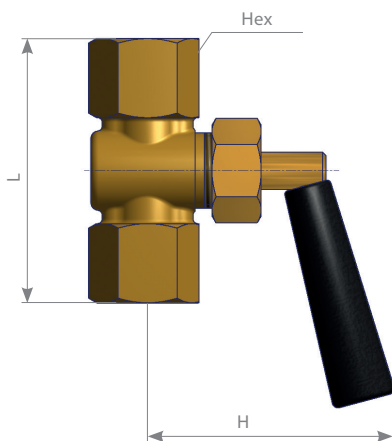

Inlet	Outlet	Material	PN	L	H	Hex	Test Connection	Remarks	Part Number
G 1/2 Female	G 1/2 Female	Brass	25	70	65	27			N003.09.000
							Test Flange 60 x 25 x 10	with vent	N003.09.000.02
G 1/2 Male				77					N003.10.000
						with vent	N003.10.000.02		

Gauge Cocks

Male x Female (Adjusting Nut) Connections

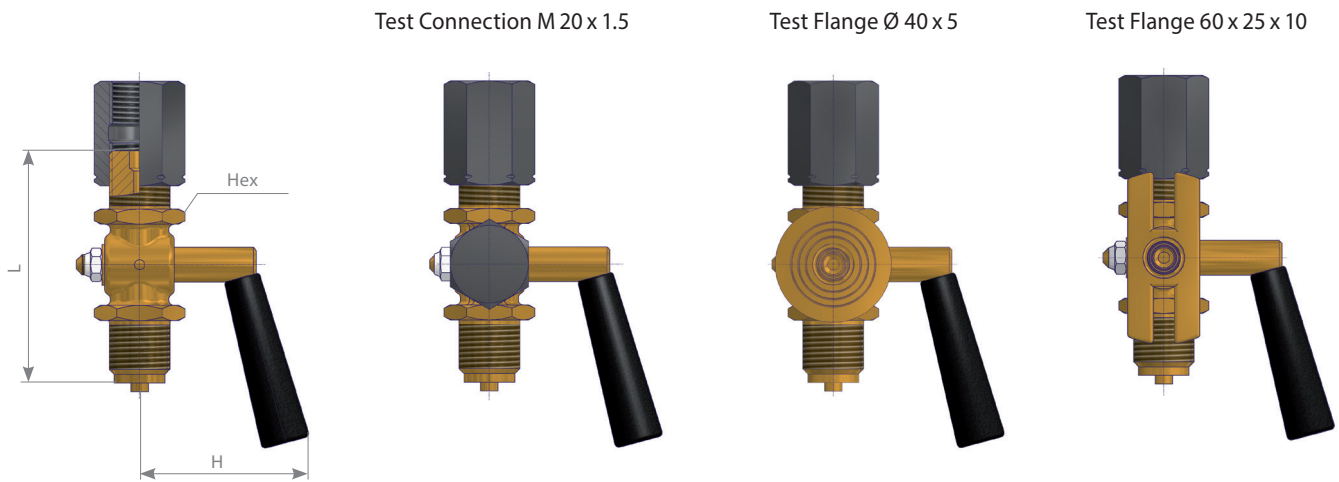

Inlet	Outlet	Material	PN	L	H	Hex	Test Connection	References	Part Number	
G 1/4 Male	G 1/4 Adjusting Nut	Brass	6	55	30	17		DIN 16262 Type B	S003.42.000	
G 1/2 Male	G 1/2 Adjusting Nut	Brass (AP)*	25	80	57	27	M 20 x 1.5 c/w Protective Cap	DIN 16262 Type A	N003.30.000	
		1.4571		83					S003.30.000.32	
		Brass		80					DIN 16262 Type A	S003.30.200
		Brass (AP)*							DIN 16263 Type A	N003.31.000
		1.4571						83		S003.31.000.32
		Brass						80		DIN 16263 Type A
		Stainless Steel		83				Test Flange 60 x 25 x 10	N003.36.000	
								80	Test Flange Ø 40 x 5	N003.36.200
M 20 x 1.5 Male	M 20 x 1.5 Adjusting Nut	Brass		80			M 20 x 1.5 c/w Protective Cap		N003.38.000	
		1.4571		83					N003.30.050	
									N003.31.050	
									S003.31.250	

* Brass (AP) = Body, Adjusting Nut and Protective Cap in Brass

Product Description

AS-Schneider Gauge Protectors are used to protect pressure-sensing instruments against damage, loss of accuracy, and/or rupture in the event of excessive system pressure. The piston assembly works against an adjustable spring. The piston assembly contains a sealing mechanism to isolate system pressure from the instrument.

The Inlet to Outlet seal is an O-Ring, the sealing to atmosphere is realized by either another O-Ring (system pressures of more than 2 bar) or a diaphragm (for system pressures 0.4 up to 2.5 bar). As system pressure overcomes the force of the spring, the piston moves, causing the sealing system to close. The outlet side is now isolated from increasing system pressure and the instrument is protected. As system pressure drops to the reopening pressure (25% below the closing pressure), the valve opens again.

Standard Features

- Forged Body
- Piston Seals:
 - FKM (FPM by ISO)
 - Diaphragm in NBR for the DVGW approved type
- Max. allowable (Working) Pressure (PS): 600 bar
- Max. Inlet Pressure: 1,000 bar (except Brass Type: 600 bar)
- Max. allowable Temperature (TS) 80°C, resp. 60°C for our DVGW approved types S005.50.001.00DV / 201.00DV

The Gauge Protectors are as a standard available for sour gas service in accordance with NACE MR0175/MR0103 and ISO 15156 except the Brass Type.

Pressure Test:

A shell test and a seat test are performed at 1.5 times the max. allowable (working) pressure acc. to EN 12266-1 - P10, P11 and P12. The closing pressure is normally adjusted to the average value of the relevant adjusting range – For example adjusting range 2-6 bar = 4 bar closing pressure.

Optional Features

DVGW approved Gauge Protectors:

AS-Schneider is offering Gauge Protectors which have been tested and approved by DVGW. The test basis is DVGW VP 308. The valves are applicable for all kinds of gas in accordance with DVGW-list number G 260.

Pressure-Temperature Rating:

- Max. 400 bar @ -20°C up to +60 / +80°C

- DVGW-Approval-No.: DG-4515BP0208

- Part No. Suffix ...00DV for DVGW types

Oxygen Service:

AS-Schneider offers an option cleaned and lubricated for Oxygen Service – Suffix F0:

- Max. allowable (Working) Pressure (PS): 400 bar
- Max. allowable (Working) Temperature (TS): 60°C

- A choice of O-Ring materials is available.

Certification:

Inspection certificate 3.1 acc. to EN 10 204 for valve body material and pressure test available on request.

Components	Brass	Stainless Steel	Duplex	Alloy 400	Alloy C-276	Alloy 625
	Material / Material No.					
Body	Brass	1.4571				
Bonnet		316*	Duplex	Alloy 400	Alloy C-276	Alloy 625
Piston	1.4404*					
Piston Seals	FKM (FPM by ISO)					
Screw Plug	1.4404*		Duplex	Alloy 400	Alloy C-276	Alloy 625
Adjusting Screw	1.4404*					
Spring	Stainless Steel					
Adjusting Nut	Unalloyed Steel	Stainless Steel				

* 316 / 316L / 1.4401 / 1.4404

Gauge Protectors

Gauge Protector Type S005.50

Gauge Protector Design
For System Pressures 2 - 600 bar

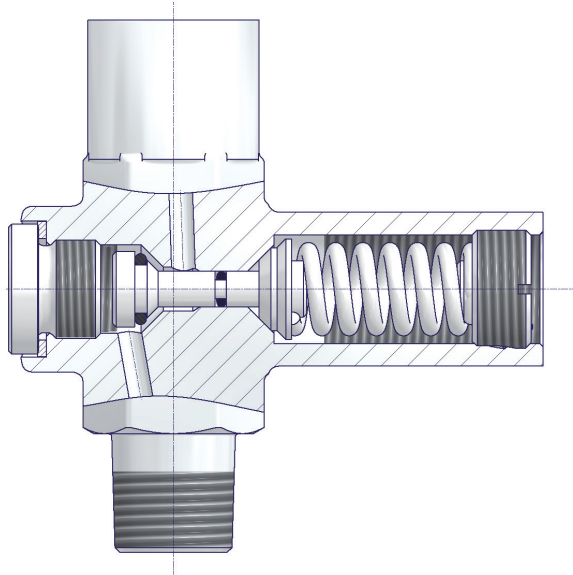

Gauge Protector Design
For System Pressures 0.4 - 2.5 bar

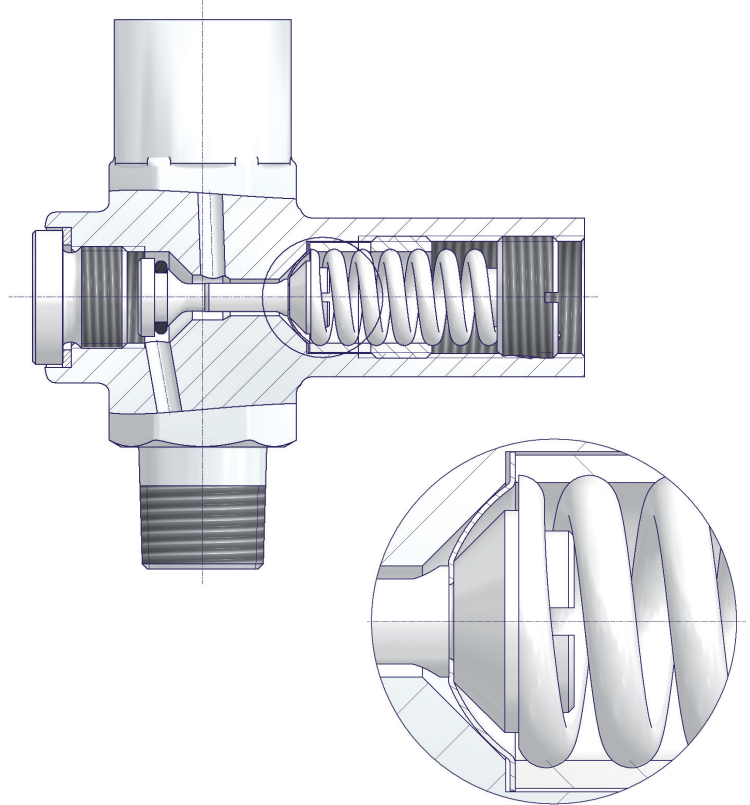

Gauge Protector Type N005.50

Screwed Bonnet Design

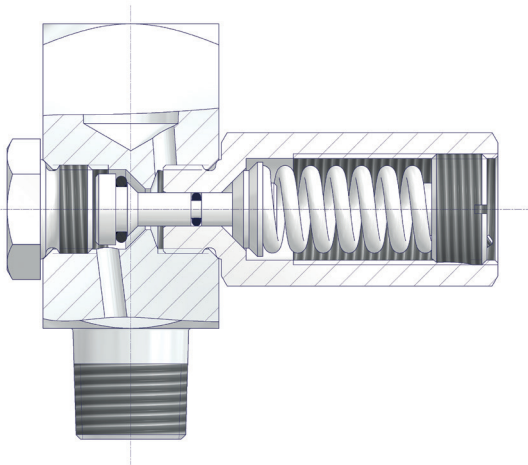

Gauge Protector Type S005.50

Outlet Adjusting Nut

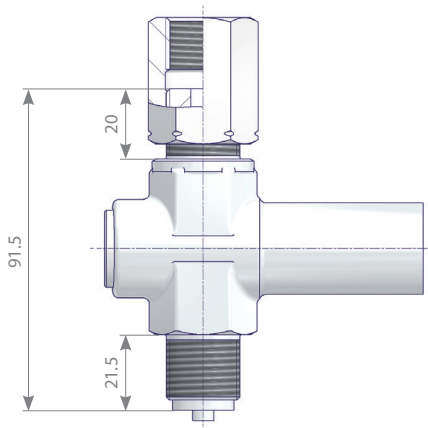

Outlet Female NPT

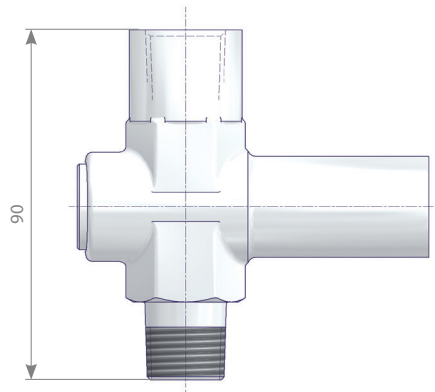

Gauge Protector Type N005.50

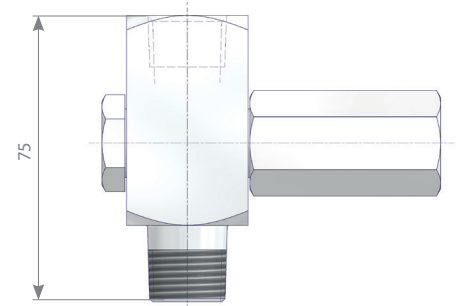

Parallel Threads

Inlet	Outlet	Material	Adjusting range in bar						
			0.4 - 2.5	2 - 6	5 - 25	20 - 60	50 - 250	240 - 400	400 - 600
G 1/2 Male	G 1/2 Adjusting Nut	Brass	S005.50.001	...002	...003	...004	...005	...006	...007
			S005.50.001.00DV	...002.00DV	...003.00DV	...004.00DV	...005.00DV	...006.00DV	
		1.4571	S005.50.201	...202	...203	...204	...205	...206	...207
			S005.50.201.00DV	...202.00DV	...203.00DV	...204.00DV	...205.00DV	...206.00DV	
M 20 x 1.5 Male	M 20 x 1.5 Adjusting Nut		S005.50.251	...252	...253	...254	...255	...256	...257

NPT Threads

Inlet	Outlet	Material	Adjusting range in bar						
			0.4 - 2.5	2 - 6	5 - 25	20 - 60	50 - 250	240 - 400	400 - 600
1/2 NPT Male	1/2 NPT Female	Brass	S005.50.021	...022	...023	...024	...025		
		1.4571	S005.50.221	...222	...223	...224	...225	...226	
		316	N005.50.421	...422	...423	...424	...425	...426	...427
		Duplex	N005.50.821.0001	...822.0001	...823.0001	...824.0001	...825.0001	...826.0001	...827.0001
		Alloy 625	N005.50.821.0009	...822.0009	...823.0009	...824.0009	...825.0009	...826.0009	...827.0009
		Alloy 400	N005.50.921.0001	...922.0001	...923.0001	...924.0001	...925.0001	...926.0001	...927.0001
		Alloy C-276	N005.50.921.0005	...922.0005	...923.0005	...924.0005	...925.0005	...926.0005	...927.0005
1/4 NPT Male	1/4 NPT Female	Brass	S005.50.041.01	...042.01	...043.01	...044.01	...045.01	...046.01	
		1.4571	S005.50.241.01	...242.01	...243.01	...244.01	...245.01	...246.01	...247.01

Gauge Snubbers | Features and Benefits

Product Description

AS-Schneider Gauge Snubbers are used to improve the output or readability of the instrument, and to reduce the effect of pressure surges on the instrument.

They also limit the external discharge of the pressure medium, in the event a discontinuity should occur on the instrument side of the snubber. Closing the valve increases the dampening action.

Standard Features

- Forged Body in Brass, all other materials in Barstock Material
- Max. allowable (Working) Pressure (PS): 400 bar
- Max. allowable Temperature (TS): 120°C
- The Gauge Snubbers are available for sour gas service in accordance with NACE MR0175/MR0103 and ISO 15156, see table on Page 23.

Optional Features

Oxygen Service:

AS-Schneider offers an option with for Oxygen Service – Suffix F0 (PN 250) or F5 (PN400):

- Max. allowable (Working) Pressure (PS): 400 bar
- Max. allowable (Working) Pressure (TS): 60°C

- A choice of O-Ring materials is available.

Certification:

Inspection certificate 3.1 acc. to EN 10 204 for valve body material and pressure test available on request.

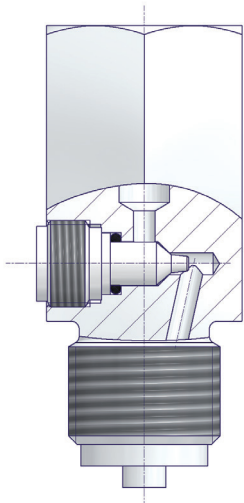

Components	Brass	Carbon Steel	Stainless Steel	Duplex	Alloy 400	Alloy C-276	Alloy 625	
	Material / Material No.							
Body	Brass	Carbon Steel	1.4571	316*	Duplex	Alloy 400	Alloy C-276	Alloy 625
Valve Stem	1.4404*							
O-Ring	NBR		FKM (FPM by ISO)					
Screw Plug	Brass	Unalloyed Steel	1.4571					

* 316 / 316L / 1.4401 / 1.4404

Parallel Threads

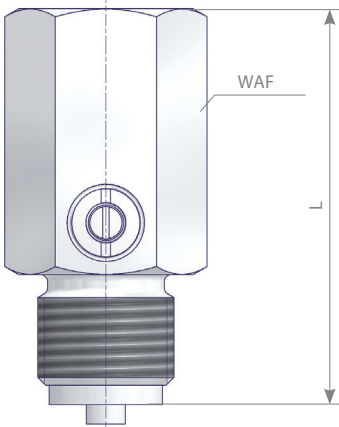

Inlet	Outlet	Material	PN	L	WAF	Special Features	Part Number	
G 1/4 Male	G 1/4 Female	Brass	250	62.5	27		S005.10.030.01	
		Carbon Steel	400	61			S005.10.130.01	
		1.4571	400	61		NACE	S005.10.230.01	
G 3/8 Male	G 3/8 Female	Brass	250	62.5				S005.10.020.01
		1.4571	400	61		NACE	S005.10.220.01	
G 1/2 Male	G 1/2 Female	Brass	400	62.5				S005.10.000
		Carbon Steel	400	61				S005.10.100
		1.4571	400	61		NACE	S005.10.200	
M 20 x 1.5 Male	M 20 x 1.5 Female	Brass	400	62.5				S005.10.050
		Carbon Steel	400	61				S005.10.150
		1.4571	400	61		NACE	S005.10.250	

NPT Threads

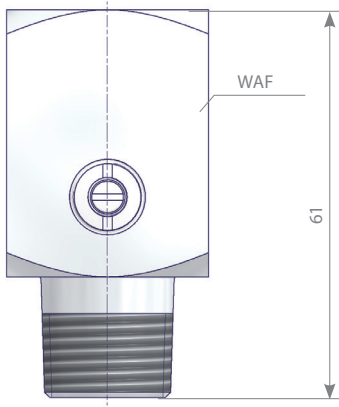
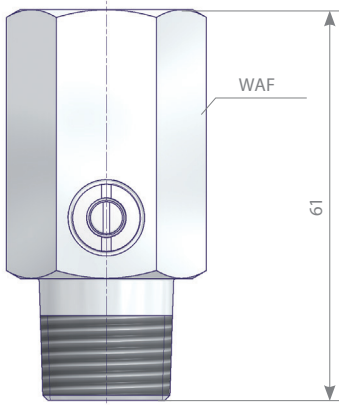

Inlet	Outlet	Material	PN	L	WAF	Special Features	Part Number		
1/4 NPT Male	1/4 NPT Female	Brass	250	61	27		S005.10.031.01		
		1.4571	600			NACE	S005.10.231.01		
1/2 NPT Male	1/2 NPT Female	Brass	250						S005.10.010
		Carbon Steel							S005.10.110
		1.4571						NACE	S005.10.210
		316						NACE	S005.10.410
		Duplex	400			32	NACE	S005.10.810.0001	
		Alloy 625				32	NACE	S005.10.810.0009	
		Alloy 400				27	NACE	S005.10.910.0001	
		Alloy C-276				32	NACE	S005.10.910.0005	

WAF = Width Across Flats | 27 = Hex, 32 = Square

Gauge Snubber Type made from 32 mm square barstock material.

Supports for Valves and Measuring Instruments

AS-Schneider is providing a range of supports for wall, rack or 2" pipe mounting to mount Gauge Valves according to DIN 16270–16272 Type B or Adapters relating to DIN 16281 (see Page 33).

Standard extension L = 100 mm. Type H(G) also available with 60 and 160 mm extension

The below mentioned part numbers for 2" pipe mounting are supplied as mounting kits including 'U' bolt, washers and hexagon nuts.

Bolts for wall mounting are not included in the scope of supply.

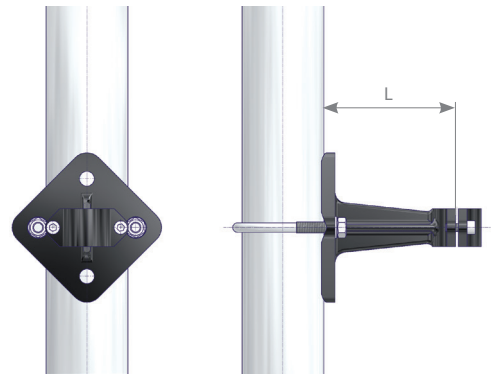

Supports DIN 16281 Type H(G) and Type H(S) For wall mounting

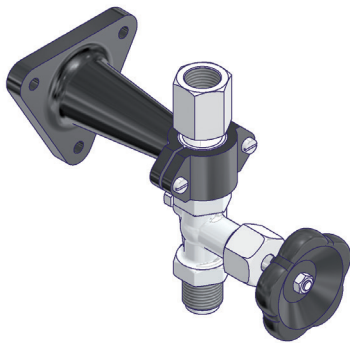

L (mm)	Design	Material	Installation Method	Part Number
60	DIN 16281 Type H(G)	Aluminium, coated	For wall mounting	S006.12.105
100	DIN 16281 Type H(G)			S006.12.115
160	DIN 16281 Type H(G)			S006.12.125

L (mm)	Design	Material	Installation Method	Part Number
100	DIN 16281 Type H(S)	Stainless Steel	For wall mounting	S006.12.215

Stainless Steel type not illustrated.

Supports DIN 16281 Type A(G) For wall mounting or 2" pipe mounting

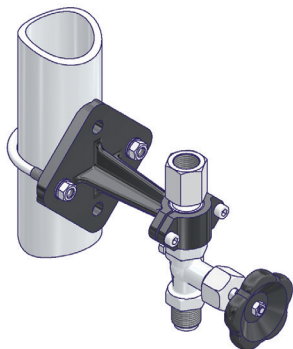

L (mm)	Design	Material	Installation Method	Part Number
100	DIN 16281 Type A(G)	Malleable cast iron galvanized and coated	For wall mounting	N006.12.110
			For 2" pipe mounting	S006.39.100.11

Mounting Kit for 2" pipe mounting in carbon steel with galvanized surface.

Supports DIN 16281 Type A(S) For wall mounting or 2" pipe mounting

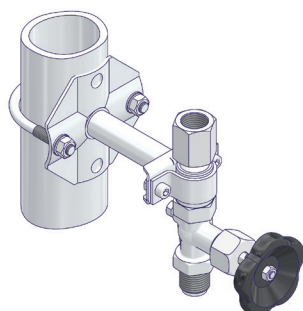

L (mm)	Design	Material	Installation Method	Part Number
100	DIN 16281 Type A(S)	Stainless Steel	For wall mounting	S006.12.216.54
			For 2" pipe mounting	S006.12.217.54

Mounting Kit for 2" pipe mounting in stainless steel.

Product Description

AS-Schneider Gauge Syphons are used to protect the pressure gauge from the effect of hot pressure media such as steam and also to reduce the effect of rapid pressure surges. The syphon allows condensate to form and be collected inside the syphon, preventing the hot media (hot vapors, not just steam) from coming in direct contact with the pressure instrument. Also used as freeze protector when used with proper fill fluids.

AS-Schneider is providing 3 different syphon designs. The Coil Syphon is normally used for vertical installations and the U Type Syphon for horizontal installations. The third design is a compact Gauge Syphon which can be used instead of the Coil Syphon. In addition, AS-Schneider is providing pipe connectors where a syphon is not required, such as Elbows and Straight Pipes.

The standard syphons are designed, manufactured and tested according to DIN 16282. The standard pipe dimension is $\varnothing 20 \times 2.6$ mm. 1/2" pipe ($\varnothing 21.3$ mm) dimensions are also available. AS-Schneider is also providing so-called Commercial Style Syphons. These types have a standard pipe dimension of $\varnothing 21.3 \times 3.2$ mm – using threaded pipe connections instead of weld fittings. The Compact Gauge Syphon is available as standard type and also as integral snubber type.

Standard Features

- The standard DIN 16282 U Type Syphon is bended to the left side, optional also to the right side (see also Page 27).
- Commercial Style U Type Syphons are bended in a single-plane
- Range of application: For liquids, gas, steam and vapors

Surface treatment of Carbon Steel Types:

- DIN 16282 Style: Phosphatized
- Commercial Style: Oiled, optional phosphatized

Certification:

Inspection certificate 3.1 acc. to EN 10 204 for pipe material available on request.

Optional Features

The standard AS-Schneider circular shaped syphons are Coil Syphons. Should you require Pigtail Syphons please contact the factory.

Coil Syphon



Pigtail Syphon



Other Materials, Pressure-Temperature Ratings and Connections on request.

Pressure-Temperature Ratings

Coil and U Type Syphons and Elbows

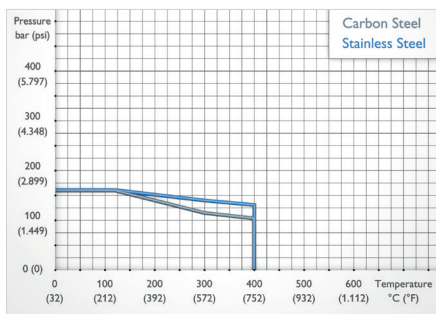

Straight Pipes

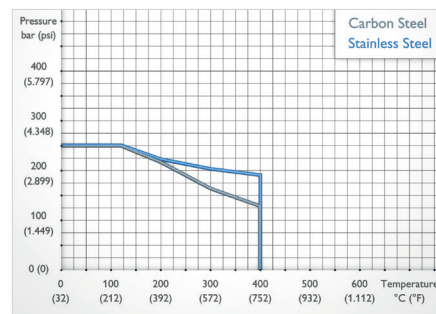

Compact Gauge Syphon

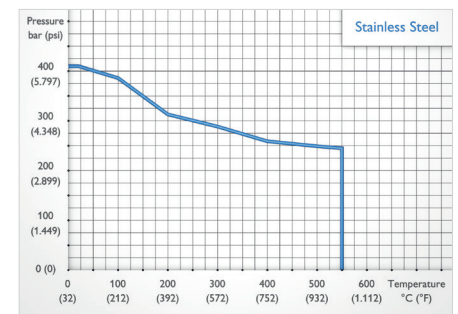

Components	Carbon Steel	Stainless Steel
	Material / Material No.	
Pipe	1.0345	1.4571
Pipe Connector	1.1141	
Adjusting Nut	Carbon Steel	Stainless Steel

Components	Stainless Steel
	Material / Material No.
Body	1.4571
Tubes	
Swivel Nut	

Syphon Features

Syphon Details

DIN 16282 Style Syphons

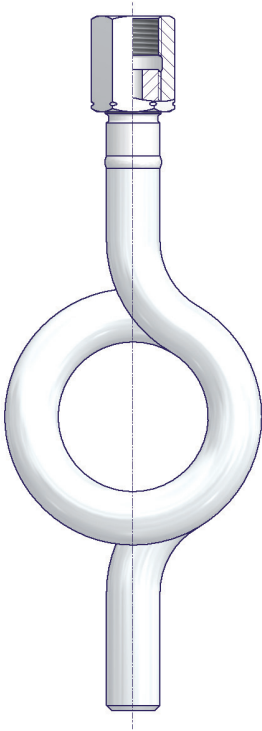

Commercial Style Syphons

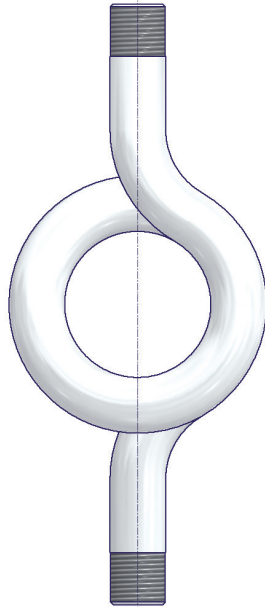

Standard Syphon

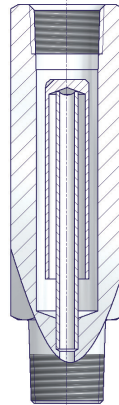

Integral Snubber Type

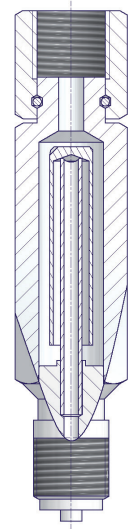

Integral Snubber Type

Slot in deflection tube to minimize pressure surges and equalize pressure all inside the syphon

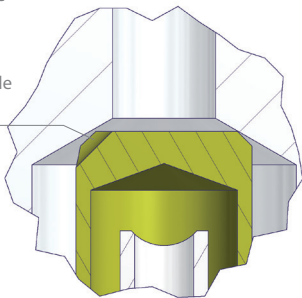

The Integral Snubber Type Syphon eliminates damage due to pressure surges. A slot is providing an auto reset of the deflector tube.

Position of the deflector tube in case of a pressure surge.

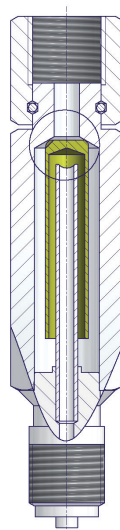

Normal operating position of deflector tube.

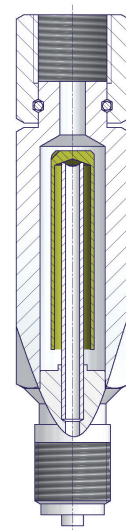

Applications

Horizontal Installation (horizontal tap)
U Type Syphon orientations

Bended to the left side
(standard)



Bended to the right side

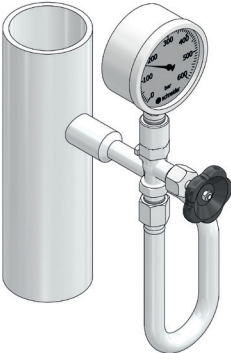

Single-plane bend

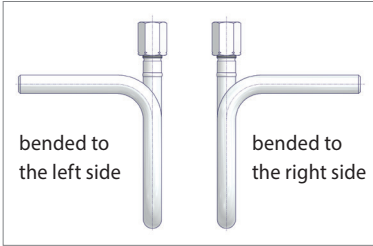

Vertical Installation (vertical tap)
Compact Gauge Syphon and Coil Syphon

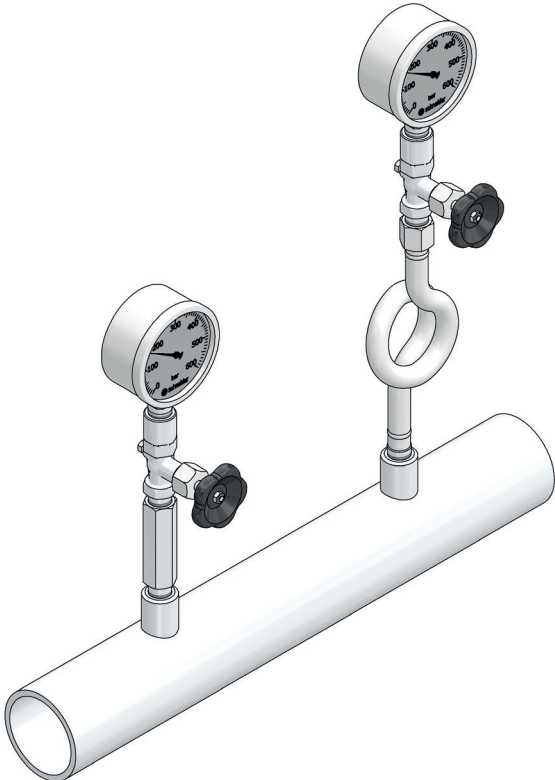

U Type Syphons

Standard Syphons

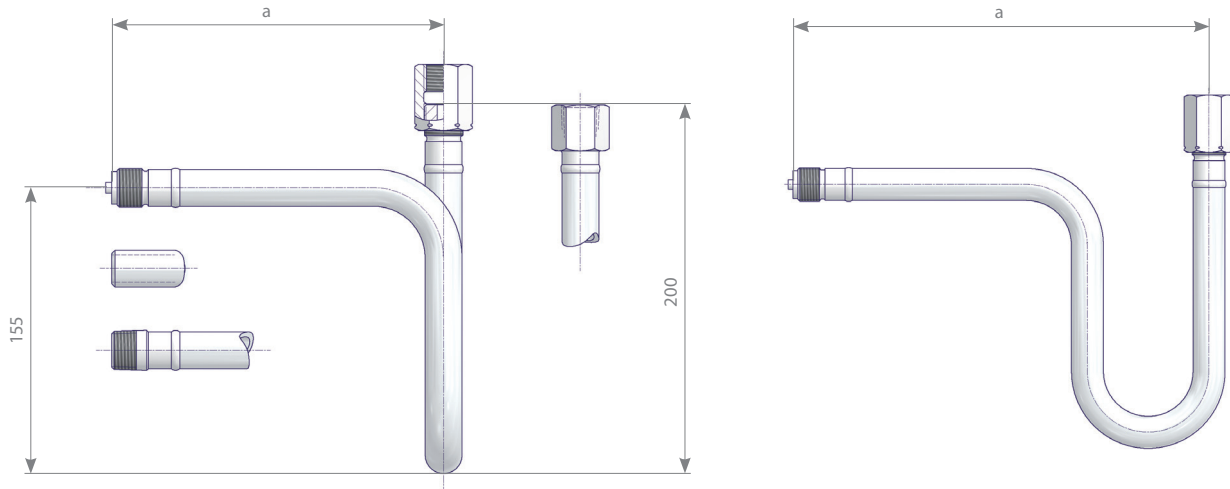

Inlet	Outlet	Dimension a (mm)	Material	References	Part Number
Butt Weld End Ø 20 x 2.6	G 1/2 Adjusting Nut	145	1.0345	DIN 16282 Type B	S006.07.110
		218		Single-plane bend	S006.07.110.05
		145	1.4571	Bended to the right side	S006.07.110.20
		218		DIN 16282 Type B	S006.07.210
G 1/2 Male		180	1.0345	DIN 16282 Type A, Rev. 11/1988	S006.07.100
		253		Single-plane bend	S006.07.100.05
		180	1.4571	DIN 16282 Type A, Rev. 11/1988	S006.07.200
		253		Single-plane bend	S006.07.200.05
Butt Weld End Ø 20 x 2.6	1/2 NPT Female	145	1.0345		S006.07.110.18
			1.4571		S006.07.210.18
1/2 NPT Male	1/2 NPT Female	180	1.0345		S006.07.100.16
			1.4571		S006.07.200.16

Commercial Style Syphons

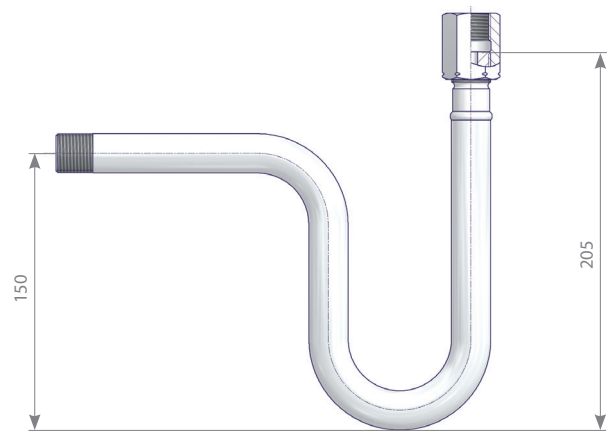
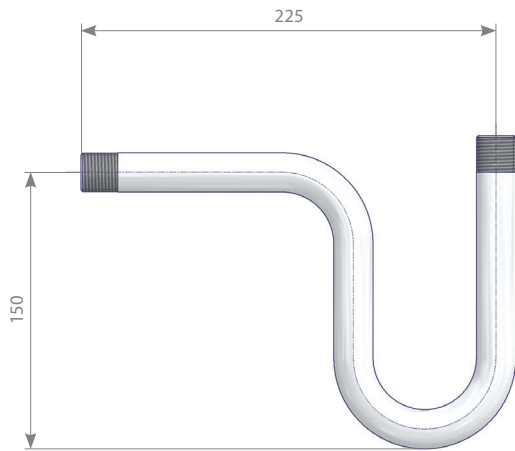

Inlet	Outlet	Material	References	Part Number
G 1/2 Male	G 1/2 Male	1.4571		S006.07.205.01
		1.0345		S006.07.105.01
	G 1/2 Adjusting Nut			Surface Treatment: Phosphatized
				Surface Treatment: Phosphatized

Coil Syphons

Standard Syphons

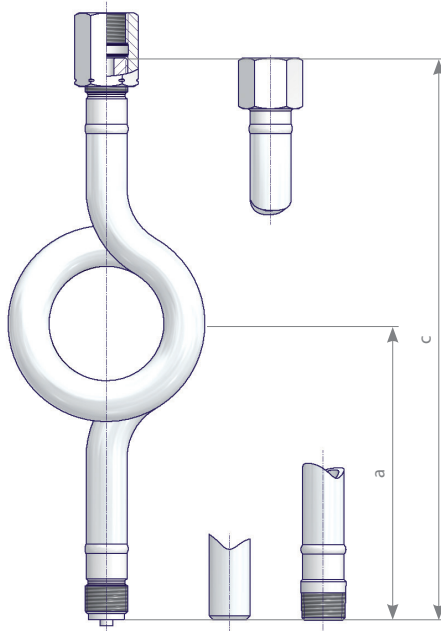

Inlet	Outlet	Dimension (mm)		Material	References	Part Number	
		a	c				
Butt Weld End Ø 20 x 2.6	G 1/2 Adjusting Nut	110	240	1.0345	DIN 16282 Type D	S006.08.110	
				1.4571	DIN 16282 Type D	S006.08.210	
G 1/2 Male		145	275	1.0345	DIN 16282 Type C Rev. 11/1988	S006.08.100	
				1.4571	DIN 16282 Type C Rev. 11/1988	S006.08.200	
				1.0345		S006.08.100.18	
				1.4571		S006.08.200.18	
1/2 NPT Male		1/2 NPT Female	110	240	1.0345		S006.08.100.16
					1.4571		S006.08.200.16
Butt Weld End Ø 20 x 2.6	1.0345					S006.08.110.18	
	1.4571					S006.08.210.18	
M 20 x 1.5 Male	M 20 x 1.5 Adjusting Nut	145	275	1.4571		S006.08.250	

Commercial Style Syphons

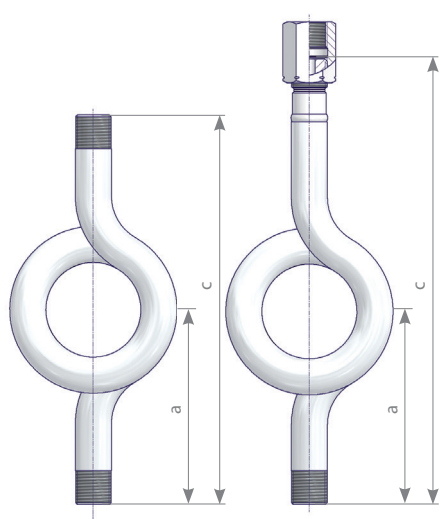

Inlet	Outlet	Dimension (mm)		Material	Special Features	Part Number
		a	c			
G 1/2 Male	G 1/2 Male	115	230	1.0345		S006.08.105.01
				1.4571	Surface Treatment: Phosphatized	S006.08.105.12
						S006.08.205.01
G 1/4 Male	G 1/4 Male	125	250	1.0345		S006.08.105.31
				1.4571	Surface Treatment: Phosphatized	S006.08.105.15
						S006.08.205.31
G 1/2 Male	G 1/2 Adjusting Nut	115	263	1.0345		S006.08.105.02

Compact Gauge Syphons | Straight Pipes and Elbows

Compact Gauge Syphons for Vertical Installations

Standard Syphon
1/2 NPT Connection

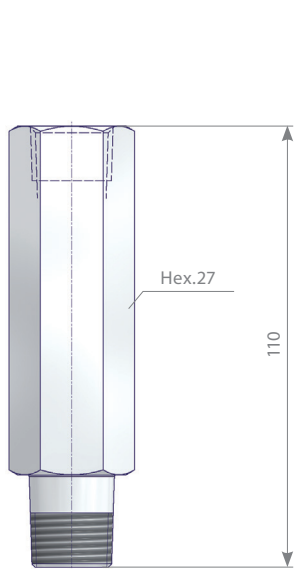

Integral Snubber Type
G 1/2 Connection

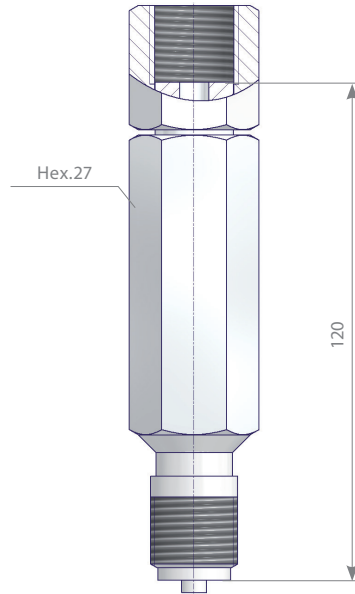

Inlet	Outlet	Material	Part Number
1/2 NPT Male	1/2 NPT Female	1.4571	S006.47.203.05
G 1/2 Male	G 1/2 Swivel Nut		S006.47.201.05

Straight Pipe

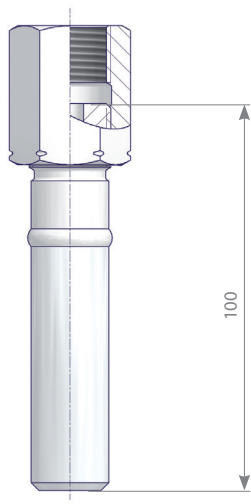

Elbow 90°

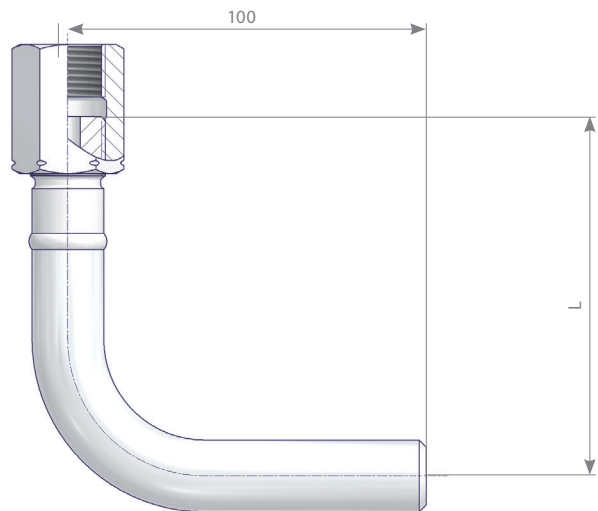

Inlet	Outlet	Material	Part Number
Butt Weld End Ø 20 x 2.6	G 1/2 Adjusting Nut	1.0345	S006.17.101.02
		1.4571	S006.17.201.02
	1/2 NPT Female	1.0345	S006.17.101.28
		1.4571	S006.17.201.28

Inlet	Outlet	Material	L	Part Number
Butt Weld End Ø 20 x 2.6	G 1/2 Adjusting Nut	1.0345	100	S006.17.100.02
			80	S006.17.102.15
	G 1/2 Adjusting Nut	1.4571	100	S006.17.200.02
			80	S006.17.202.15

Pressure Gauge Accessories

Swivel Gauge Adapters

The Swivel Gauge Adapters enable the easy positioning of the gauge in any direction through 360°.

Type 1

Screwed Design with either a PTFE seal ring or a metallic seal ring (see table)

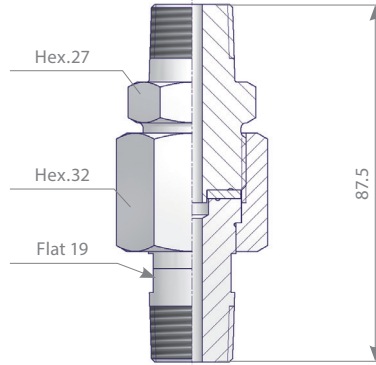
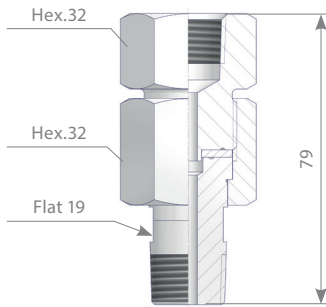

Type 2

Welded Nipple Design

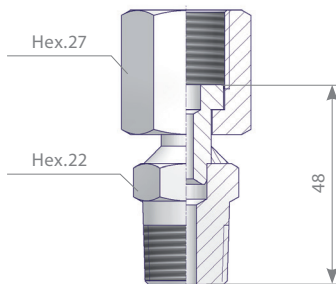

Type 3

Wire Design

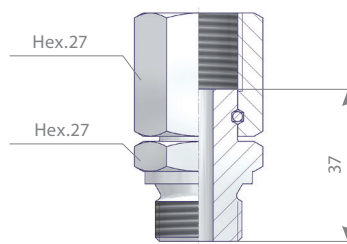

Type 4

Elbow Adapter

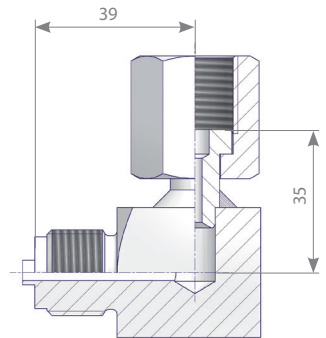

Max. allowable (Working) Pressure (PS): Type 1 10,000 psi / 689 bar
 Type 2, 3, 4 6,092 psi / 420 bar

Type	Connection 1	Connection 2	Material		Part Number
			Components	Seal Ring	
1	1/2 NPT Male	1/2 NPT Female	316*	PTFE	GS-MFSP-N4N4
			Duplex		GS-MFFP-N4N4
			Alloy 400		GS-MFMP-N4N4
			Alloy C-276		GS-MFHP-N4N4
		316*	316*	GS-MFSS-N4N4	
		Duplex	Duplex	GS-MFFS-N4N4	
		Alloy 400	Alloy 400	GS-MFMS-N4N4	
		Alloy C 276	Alloy C 276	GS-MFHS-N4N4	
		1/2 NPT Male	316*	PTFE	GS-MMSP-N4N4
2	1/2 NPT Male	G 1/2 Swivel Nut	1.4404*/1.4571		GW-MSSA-N4G4
3			1.4404*		GD-MSSA-N4G4
2		M 20 x 1.5 Swivel Nut	1.4404*/1.4571		GW-MSSA-N4M4
3		G 1/2 Male DIN 3852-2	G 1/2 Swivel Nut	1.4404*	
4	G 1/2 Male EN 837-1	G 1/2 Swivel Nut	1.4404*/1.4571		GE-MSSA-G4G4

* 316 / 316L / 1.4401 / 1.4404

Gauge Adapter DIN 16281

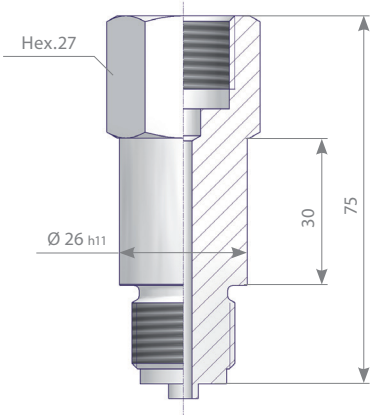

Connection 1	Connection 2	Material	Part Number
G 1/2 Male	G 1/2 Female	Brass	S006.06.000
		Carbon Steel	S006.06.100
		1.4571	S006.06.200
1/2 NPT Male	1/2 NPT Female		S006.06.215

Nipples, Union Nuts, Sealing Washers and Complete Kits

The components can be ordered separately or as Complete Kit (Part Number see table). The nipples dia. 6 and 12 mm as well as the union nuts G 1/4 and G 1/2 are according to DIN 16284. The max. allowable (Working) Pressure (PS) is 250 bar (brass) respectively 400 bar (carbon steel and stainless steel).

Thread Connection G 1/4

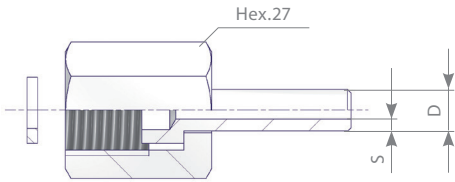

Thread Connection G 1/2 / M 20 x 1.5

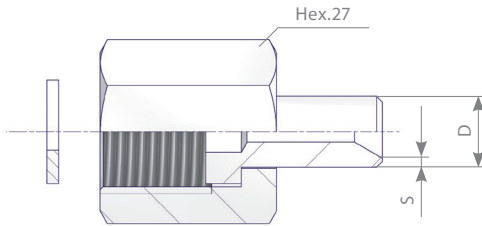

Union Nut			Nipple				Gasket		Complete Kit
Thread	Material	Part Number	D	s	Material	Part Number	Material	Part Number	Part Number
G 1/4	316/ 316L	S006.01.210*	6	1.75	316/ 316L	S006.02.210*	1.4571	S006.03.007.50	S007.45.202.21
G 1/2	Brass	S006.01.000*	12	1.5	Brass	S006.02.000*	Copper	S006.03.003	S007.45.002.01
	Carbon Steel	S006.01.100*			1.0038	S006.02.100*	Soft Iron	S006.03.004	S007.45.102.01
			1.5415	S006.02.500*	S007.45.502.01				
	316/ 316L	S006.01.200*	12	1.5	316/ 316L	S006.02.200*	1.4571	S006.03.007	S007.45.202.01
	1.1181	S006.01.107	14	2.5	1.5415	S006.02.117	Soft Iron	S006.03.004	S007.45.102.02
	S006.01.207				S006.02.217			S007.45.202.02	
M 20 x 1.5	316/ 316L	S006.01.250	12	1.5	316/ 316L	S006.02.200	1.4571	S006.03.007	S007.45.214.01
		S006.01.257	14	2.5		S006.02.217			S007.45.214.02

* According to DIN 16284.

Pressure Gauge Accessories

Sealing Washer EN 837-1

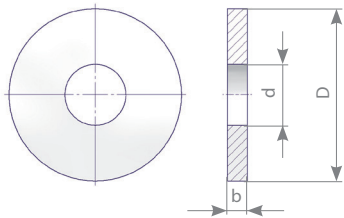

For Thread	Dimensions in mm			Material	Remarks	Part Number
	D	d	b			
G 1/4	9.5	5.2	1.5	Copper		S006.03.003.50
				1.4571		S006.03.007.50
				PTFE		S006.03.008.50
G 3/8	13	5.7	2	Copper		S006.03.053
G 1/2 and M 20 x 1.5	17.5	6.2	2	Aluminium		S006.03.002
				Copper		S006.03.003
				Soft Iron		S006.03.004
				Vulcanized Fiber		S006.03.005
				1.4571		S006.03.007
				1.4571	Grooved Gasket	S006.03.007.05
				PTFE		S006.03.008
1.4401	Corrugated Gasket	S006.03.013.02				

Adjusting Nut DIN 16283

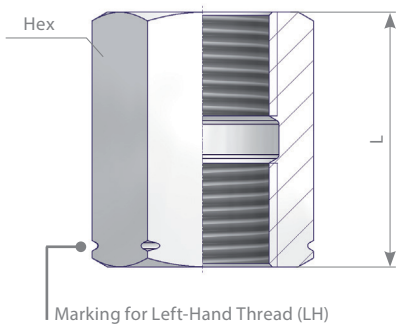

Connection 1	Connection 2	Material	L (mm)	Hex (mm)	Part Number
G 1/2-LH Female	G 1/2 Female	Brass	36	27	S006.00.000
		Carbon Steel	36	27	S006.00.100
		1.1181	36	27	S006.00.400
		1.4571	36	27	S006.00.200
G 1/4-LH Female	G 1/4 Female	Brass	23	17	S006.00.010
		Carbon Steel	23	17	S006.00.110
M 20 x 1.5-LH Female	M 20 x 1.5 Female	Brass	36	27	S006.00.050
		Carbon Steel	36	27	S006.00.150
		1.4571	36	27	S006.00.250

Pipe Connector

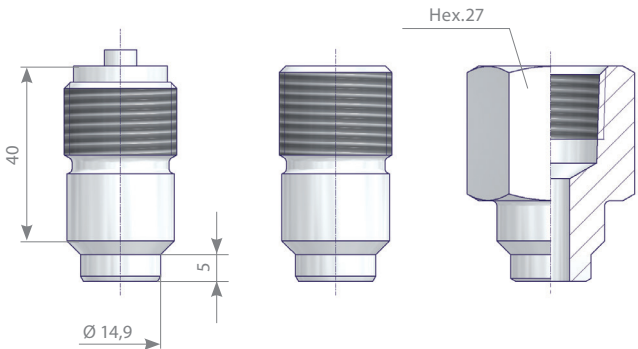

Thread Connection	Material	References	Part Number
G 1/2 Male	1.1141		S006.07.102
	1.5415		S006.07.602
	1.4571		S006.07.202
G 1/2-LH Male	1.1141	DIN 16282 Type 6	S006.07.103
	1.5415		S006.07.603
	1.4571		S006.07.203
M 20 x 1.5-LH Male	1.1141		S006.07.153
	1.4571		S006.07.253
1/2 NPT Male	1.1141		S006.07.102.01
	1.4571		S006.07.202.01
1/2 NPT Female	1.0038		S006.07.104.02
	1.4571		S006.07.204.02

Detailed information regarding dimensions of the connections see Page 5.

Female to Male Adapter

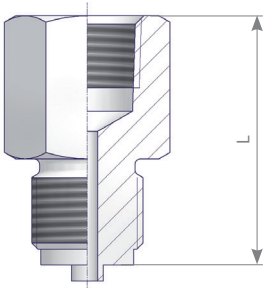

Connection 1	Connection 2	Dimension L (mm)	Material	Part Number
G 1/2 Female	1/2 NPT Male	45	1.4404	FMS-G4N4
G 1/4 Female	G 1/2 Male	31		FMS-G2G4
1/2 NPT Female		50		FMS-N4G4
G 1/2 Female	G 1/4 Male	43		FMS-G4G2

Hex Nipple

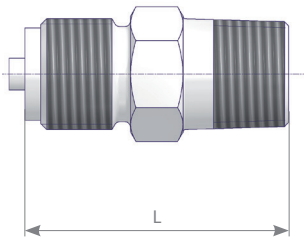

Connection 1	Connection 2	Dimension L (mm)	Material	Part Number
1/2 NPT Male	1/2 NPT Male	50	1.4404	HNS-N4N4
M 20 x 1.5 Male		50		HNS-M4N4
G 1/2 Male	1/4 NPT Male	50		HNS-G4N4
		45		HNS-G4N2
	G 1/4 Male	45		HNS-G2G4
		G 1/2 Male		50

YOUR GLOBAL PARTNER

for Instrumentation and
Double Block & Bleed Valves



Visit us on:



ARMATURENFABRIK FRANZ SCHNEIDER GMBH + CO. KG
World Headquarters
Bahnhofplatz 12, 74226 Nordheim, Germany
Tel: +49 7133 101-0
www.as-schneider.com



ARMATURENFABRIK FRANZ SCHNEIDER SRL
Gradinari 32-38, 100404 Ploiesti
Romania
Tel: +40 244 384 963
www.as-schneider.ro



AS-SCHNEIDER ASIA-PACIFIC PTE. LTD.
970 Toa Payoh North, #02-12/14/15, Singapore 318992,
Singapore
Tel: +65 62 51 39 00
www.as-schneider.sg



AS-SCHNEIDER AMERICA, INC.
17449 Village Green Dr, Houston, TX 77040
United States of America
Tel: +1 281 760 1025
www.as-schneider.com



AS-SCHNEIDER MIDDLE EAST FZE
P.O. Box 18749, Dubai
United Arab Emirates
Tel: +971 4 880 85 75
www.as-schneider.ae



AS-SCHNEIDER INDIA PRIVATE LIMITED
Rathinam Techzone Campus, Eachanari
641021 Coimbatore, Tamil Nadu, India
Tel: +91 999 544 2201
www.as-schneider.com

