

# Instrumentation Products

## Ball Valves and Ball Valve Manifolds

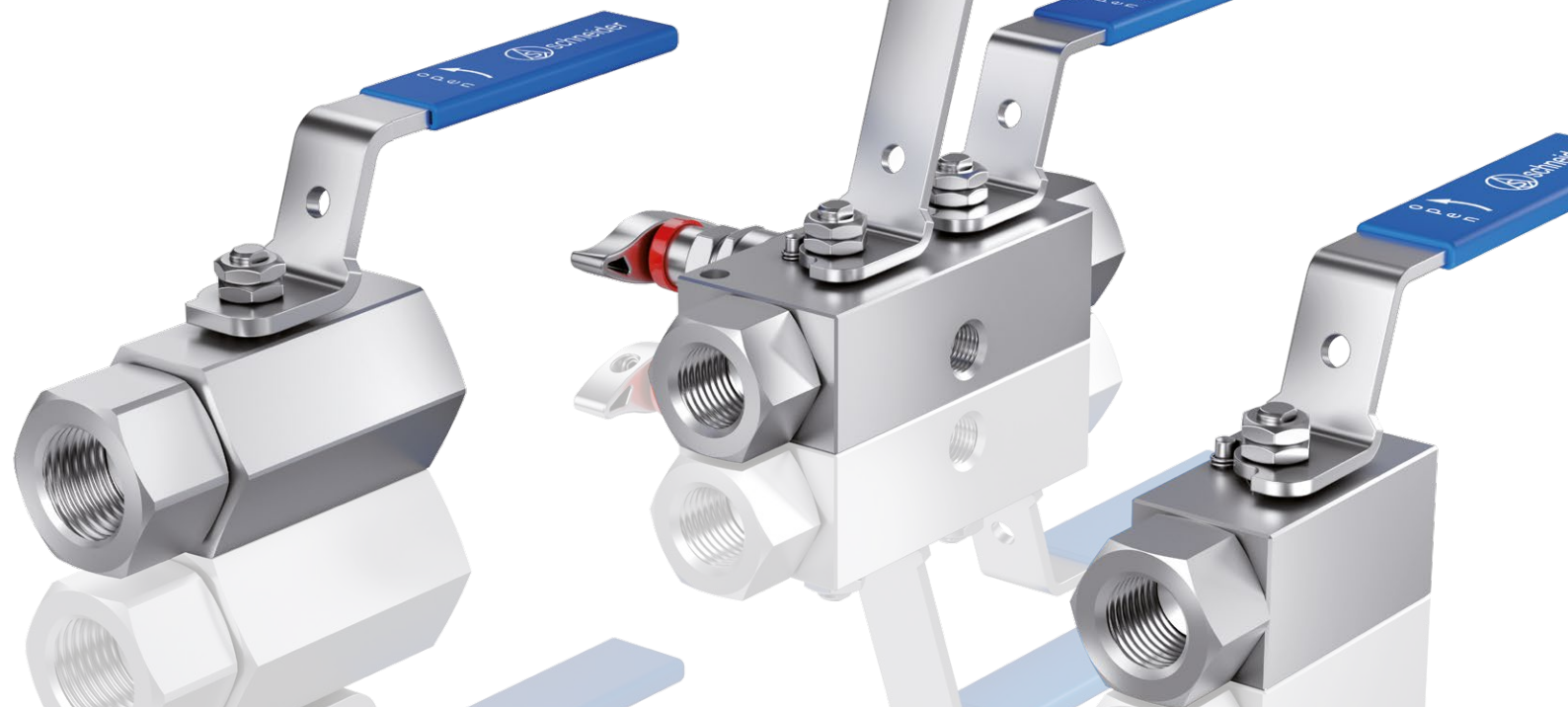

# Introduction

## Introduction

The AS-Schneider Group with its headquarters in Germany is one of the World's Leading Manufacturers of Instrumentation Valves and Manifolds. AS-Schneider offers a large variety of Ball Valves, Ball Valve Manifolds and the relevant Accessories required for instrumentation installations globally.

Selection can be made from a comprehensive range of bodies with a variety of connections and material options, optimizing installation and access opportunities. Many of the valves shown in this catalogue are available from stock or within a short period of time. The dimensions shown in this catalogue apply to standard types. If you need the dimensions for your individual type please contact the factory.

Continuous product development may from time to time necessitate changes in the details contained in this catalogue. AS-Schneider reserves the right to make such changes at their discretion and without prior notice.

All dimensions shown in this catalogue are approximate and subject to change.

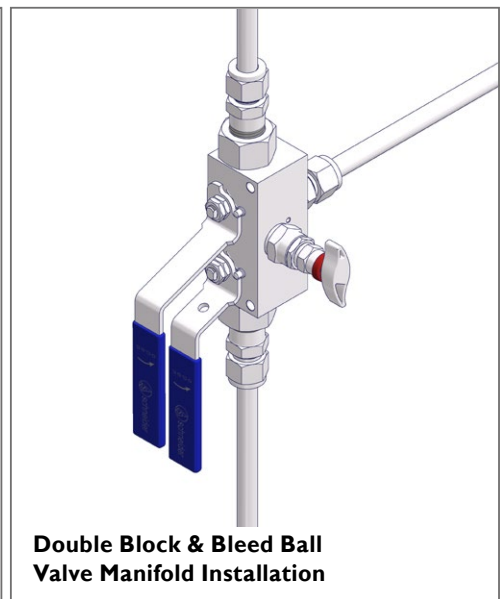
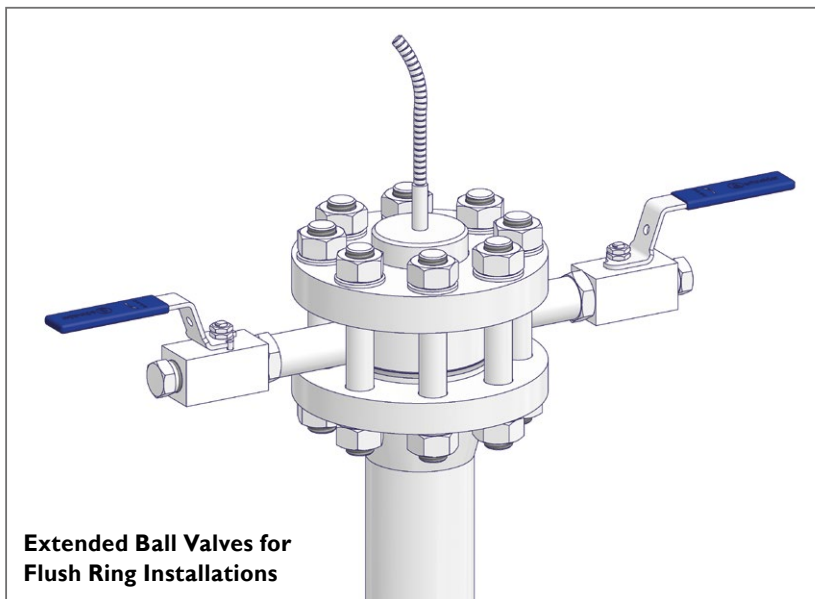

<b>Introduction</b>	page 2
<b>Contents</b>	page 3
<b>KA, KB &amp; KC Series</b>	
General Features	page 4
Materials	page 5
<b>KA Series</b>	
Standard Ball Valve Design	page 6
Dimensions	page 7
<b>KB &amp; KC Series</b>	
Standard Ball Valve Design	page 8
Dimensions	page 9
<b>KA, KB &amp; KC Series</b>	
Options	page 10
Ordering Information	page 11
<b>BA Series</b>	
Ball Valve Design	page 12
Block & Bleed Ball Valve Manifolds	page 13
Double Block & Bleed Ball Valve Manifolds	page 14
Needle Valve Design	page 15
Dimensions (DBB & BB)	page 16 / 17
Materials and General Features	page 18
Ball Valve Manifolds   Ordering Information	page 19
<b>K Series</b>	
General Features	page 20
Standard Ball Valve Design	page 21
Operation and Bonnet Options	page 22
Ordering Information	page 23
<b>KM Series</b>	
Metal Seated Ball Valves	page 24
Innovative 'Dissolution' Ball Valve Design	page 25
Ordering Information	page 26
<b>Low Pressure Ball Valves 1,000 psi (69 bar)</b>	page 27

# KA, KB & KC Series I General Features

## Standard Features

**KA Series**

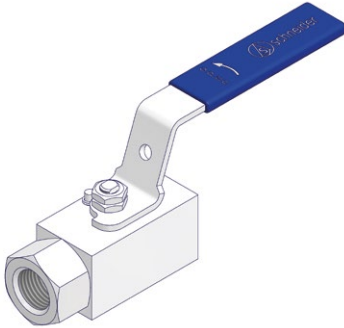

**KB Series**



**KC Series**



Series	KA	KB	KC
Bore Size mm (inch)	Ø 10 (0.39")	Ø 14 (0.55")	Ø 20 (0.79")
Basic Design	2 Piece Body Design		
	Anti-Blowout Stem		
	Floating Ball Design – Bi-Directional		
	Low Operating Torque		
	Anti-Static Design acc. to ISO 17292		
Body Shape	Square	Hexagon	
Seat Material / max. allowable (Working) Pressure (PS) bar (psi)	Reinforced PTFE 420 (6,092)	PEEK 420 (6,092)	
	PEEK 420 (6,092)	Reinforced PTFE 150 (2,175)	
	PEEK 689 (10,000) Uni-Directional		
Stem Seal Material	PTFE or Graphite	Reinforced PTFE	
Fugitive Emission Application		Tested and certified acc. to ISO 15848-1	
Fire Test	Fire-type tested and certified acc. to ISO 10497 / API 607 – For PEEK Ball Valve Seat only		

### Sour Gas Service:

Wetted parts according to a.m. material list are supplied as standard according to NACE MR0175/MR0103 and ISO 15156 (latest issue).

### Low Temperature Service:

On request.

### Oxygen Service:

On request.

### Pressure Test:

A shell test at 1.5 times the max. allowable (working) pressure and a seat leakage test are performed acc. to EN 12266-1 - P10, P11 and P12 respectively MSS-SP61 (and complies also with ASME B31.1 and B31.3) at every standard AS-Schneider Ball Valve → 100% Pressure Tested!

Pressure Test acc. to API 598 on request.

### Certification:

Certified Mill Test Report (CMTR) as Inspection certificate 3.1 acc. to EN 10 204 for valve body material and pressure test available on request.

PMI Test on request.

**Handle Options and Body Design Options see Page 10.**

## Manufactured acc. to the following Codes and Specifications

- ASME B16.34 Valves – Flanged, Threaded and Welding End
- ASME B31.3 Process Piping
- ASME B31.1 Power Piping

# KA, KB & KC Series I Materials

## Body Material Options

Material Group	AS Material Designation	Material No.	Short Name	Equivalent UNS-No.	Material Grade acc. to ASTM
Carbon Steel	A105				A105
Austenitic Stainless Steel	316 quadruple certified*	1.4401	X5CrNiMo17-12-2	S31600	316
		1.4404	X2CrNiMo17-12-2	S31603	316L
	6Mo	1.4547	X 1CrNiMoCuN20-18-7	S31254	
Austenitic-Ferritic Stainless Steel	Duplex	1.4462	X2CrNiMoN22-5-3	S31803	F51
	Superduplex	1.4410	X2CrNiMoN25.7.4	S32750	F53
Nickel Based Alloys	Alloy 400	2.4360	NiCu30Fe	N04400	
	Alloy C-276	2.4819	NiMo 16 Cr 15 W	N10276	
	Alloy 625	2.4856	NiCr22Mo9Nb	N06625	

\* Quadruple certified means 316 / 316L / 1.4401 / 1.4404

## Ball Valve Components

Components	Carbon Steel	Stainless Steel	Exotic Alloys					
	Material / Material No.							
<b>Body</b>	A105	316 / 316L	Alloy 400	Alloy C-276	Duplex	UNS S32750	Alloy 625	6Mo
<b>Body End Connector</b>								
<b>Ball</b>	316 / 316L							
<b>Stem</b>								
<b>Ball Seat</b>	Reinforced PTFE or PEEK							
<b>Body Seals (KA Series only)</b>	PTFE, Reinforced PTFE or Graphite							
<b>Stem Seals</b>								
Gland	316							
Hex Nut	316							
Handle	316							
Handle Grip	Vinyl							
Stop Pin	A4							
Anti-Static Spring	316							

Wetted components listed in **bold**.

# KA Series I Standard Ball Valve Design

## Standard Ball Valve Design – Bore Size 10 mm (0.39")

**Screwed Design** – Stem Seal: Packing

### Features

- Floating Ball Design
- Ball Valve Seat:
  - Reinforced PTFE or
  - PEEK
- Ball Seats are encapsulated in end connector / body
- Stem Seal: Standard Packing in PTFE and Graphite
- Anti-Static Design as Standard acc. to ISO 17292
- Anti-Blowout Stem Design
- Seat Leakage Class VI acc. to ANSI/FCI 70-2
- Positive Stop Pins
- Max. allowable (Working) Pressure (PS): 420 bar (6,092 psi) with PTFE and PEEK Seats → Bi-Directional
- Max. allowable (Working) Pressure (PS): 689 bar (10,000 psi) with PEEK Seats only → Uni-Directional
- All Non-wetted Parts in 316 Stainless Steel
- Fire Safe tested acc. to ISO 10497 and API 607 for PTFE and PEEK

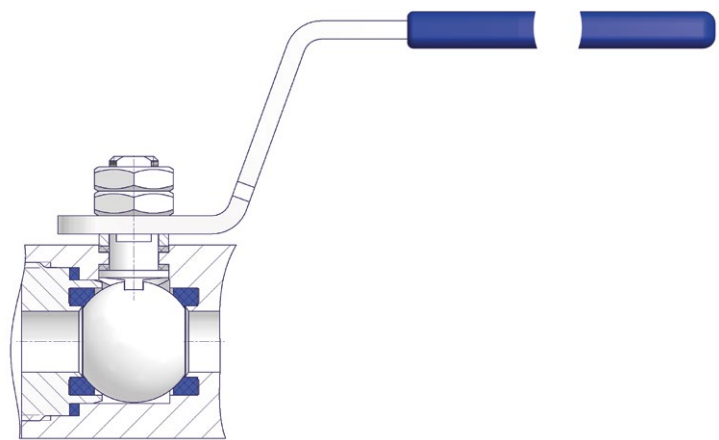
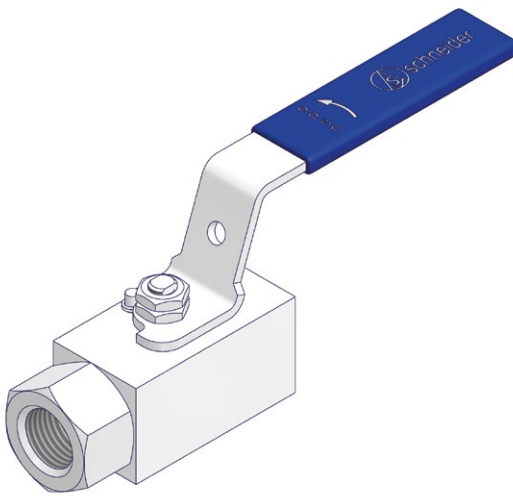

## Pressure-Temperature Ratings

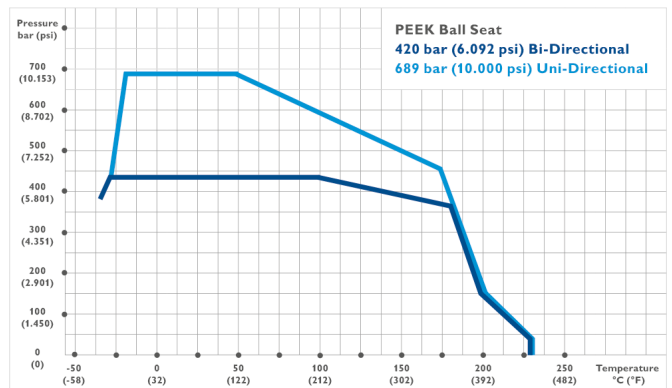
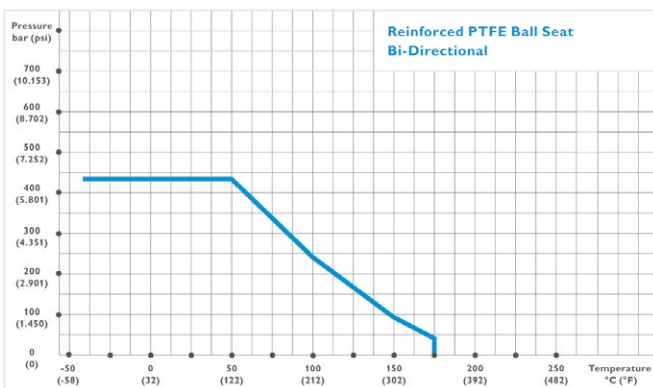

Note: Above-mentioned Pressure-Temperature Ratings are based on the standard material 316 stainless steel. Other materials as shown on page 5 might have different Pressure-Temperature Ratings.

### Low Temperature Limits:

KA1 / KA2 Type 420 bar (6.092 psi): -40°C

### Low Temperature Limits:

KA3 Type 420 bar (6.092 psi): -30°C  
 KA3 Type 689 bar (10.000 psi): -30°C  
 KA4 Type 420 bar (6.092 psi): -30°C

# KA Series I Dimensions

## Ball Valve Dimensions

### Female x Female

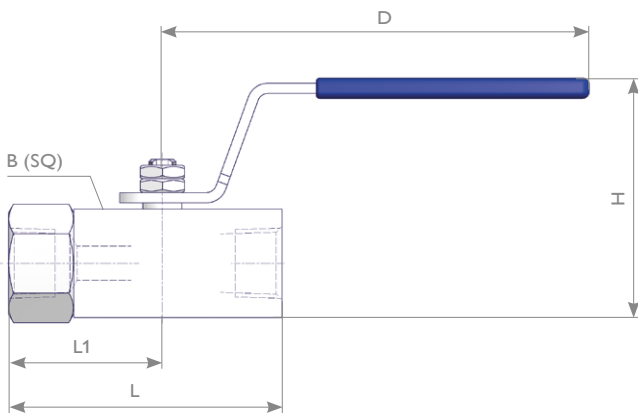

### Twin Ferrule Compression Fitting

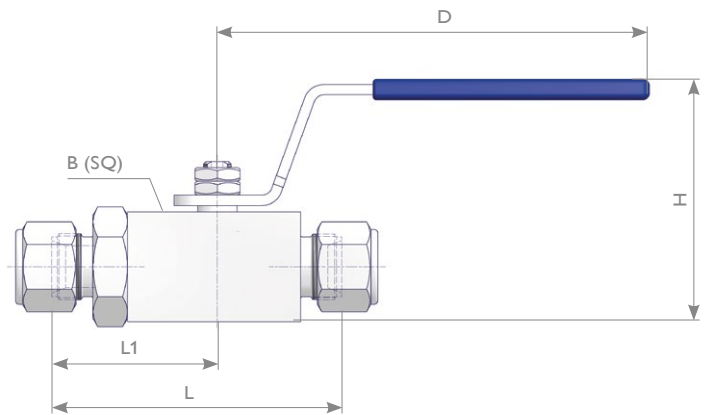

### Male x Female

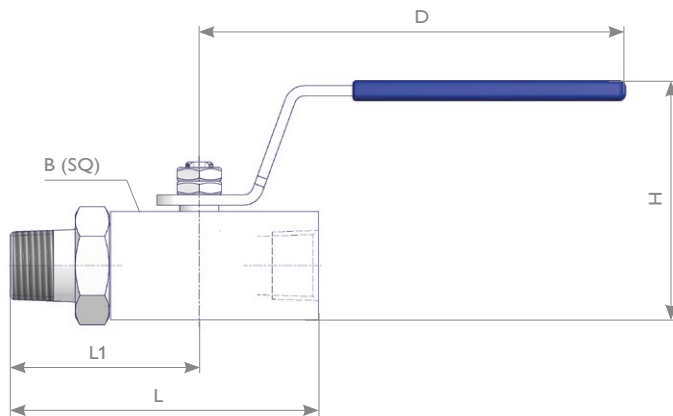

## Ball Valve Dimensions

Style	Size	Max. allowable (Working) Pressure bar (psi)	Seat Material	Standard Part Number	Bore Size mm (inch)	Dimensions mm (inch)				
						L	B	D	H	L1
Female x Female	1/2 NPT	420 (6,092)	RPTFE	KA1-LN4LN4-S	10 (0.39")	80 (3.15")	31.5 (1.25")	130 (5.1")	70 (2.76")	45 (1.77")
		689 (10,000)	PEEK	KA3-LN4LN4-SH			38.0 (1.50")		76 (3.00")	
Male x Female		420 (6,092)	RPTFE	KA1-JN4LN4-S		90 (3.54")	31.5 (1.25")		70 (2.76")	55 (2.17")
		689 (10,000)	PEEK	KA3-JN4LN4-SH			38.0 (1.50")		76 (3.00")	
Twin Ferrule Compression Fitting (Tube O.D.)	10 mm	420 (6,092)	RPTFE	KA1-HK3HK3-S	84 (3.31")	31.5 (1.25")	70 (2.76")	48 (1.89")		
	12 mm			KA1-HK4HK4-S						
	3/8"			KA1-HK8HK8-S						
	1/2"			KA1-HK9HK9-S						

# KB & KC Series I Standard Ball Valve Design

## Standard Ball Valve Design – Bore Size 14 mm (0.55") and 20 mm (0.79")

**Screwed Design** – Stem Seal: Packing

### Features

- Floating Ball Design – Bi-Directional
- Ball Valve Seat:
  - PEEK or
  - Reinforced PTFE optional
- Self Venting Ball Seats
- Stem Seal: Reinforced PTFE Packing
- Metal Sealing between body and end connector
- Anti-Static Design as standard acc. to ISO 17292
- Max. allowable (Working) Pressure (PS):
  - 420 bar (6,092 psi) with PEEK Seats and
  - 150 bar (2,175 psi) with RPTFE Seats
- Anti-Blowout Stem Design
- Seat Leakage Class VI acc. to ANSI/FCI 70-2
- Positive Stop Pins
- All Non-wetted Parts in 316 Stainless Steel
- Fire Safe tested and certified – For PEEK Ball Valve Seat only
- Ball Valve tested and certified acc. to ISO 15848-1  
(Measurement, test and qualification procedures for fugitive emissions)

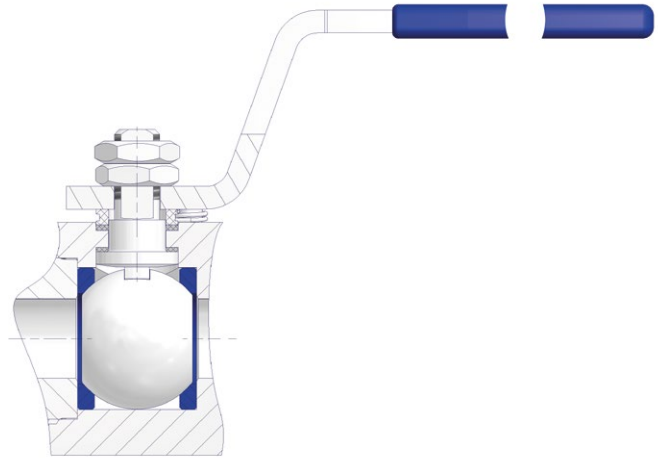

### Standard Design Material 316

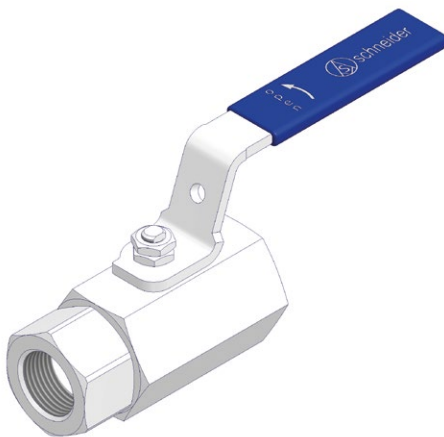

### Design concerning Exotic Materials



### Pressure-Temperature Ratings

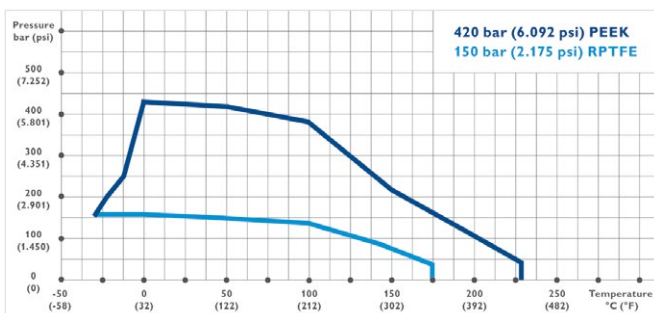

Above-mentioned Pressure-Temperature Rating is based on the standard material 316 stainless steel.

Other materials as shown on page 5 might have different Pressure-Temperature Ratings.

# KB & KC Series I Dimensions

## Ball Valve Dimensions

Female x Female

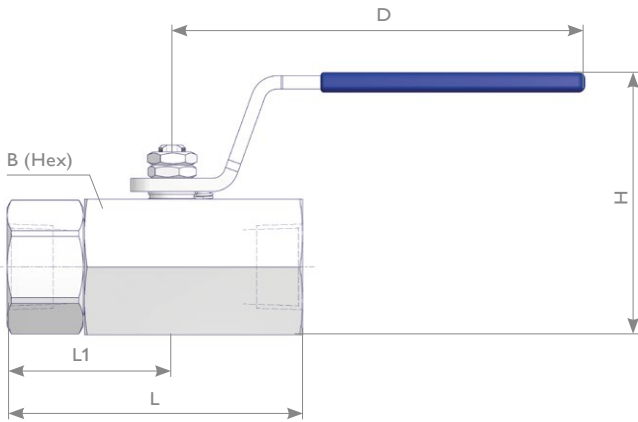

Male x Female

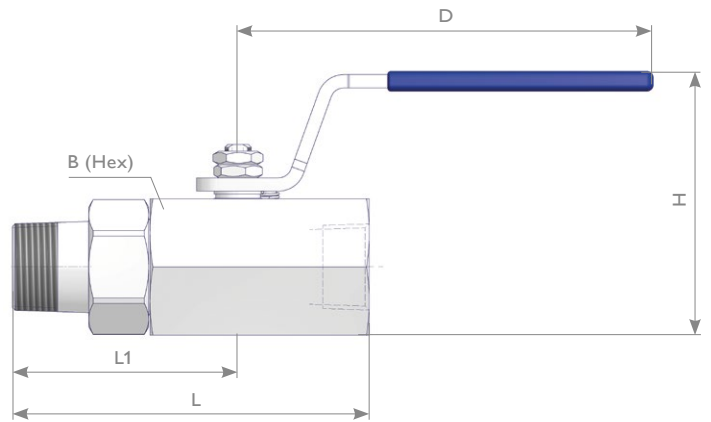

## Ball Valve Dimensions

Style	Size	Max. allowable (Working) Pressure bar (psi)	Seat Material	Standard Part Number	Bore Size mm (inch)	Dimensions mm (inch)					
						L	B	D	H	L1	
Female x Female	1/2 NPT	150 (2,175)	RPTFE	KB1-LN4LN4-S	14 (0.55")	89.4 (3.52")	41.0 (1.61")	125.0 (4.92")	79.3 (3.12")	49.9 (1.96")	
		420 (6,092)	PEEK	KB3-LN4LN4-S							
Male x Female	3/4 NPT	150 (2,175)	RPTFE	KB1-LN6LN6-S							107.4 (4.23")
		420 (6,092)	PEEK	KB3-JN6LN6-S							
Female x Female	1 NPT	150 (2,175)	RPTFE	KC1-LN6LN6-S		20 (0.79")	111.4 (4.39")	57.2 (2.25")	150.3 (5.92")	115.5 (4.55")	63.4 (2.50")
		420 (6,092)	PEEK	KC3-LN6LN6-S							
Male x Female	1 NPT	150 (2,175)	RPTFE	KC1-LN8LN8-S	132.4 (5.21")						
		420 (6,092)	PEEK	KC3-JN8LN8-S							

# KA, KB & KC Series I Options

## Ball Valve Options

### Loose Handle

Handle is supplied separately.  
(Option Code R)

KA	KB	KC
available	on request	

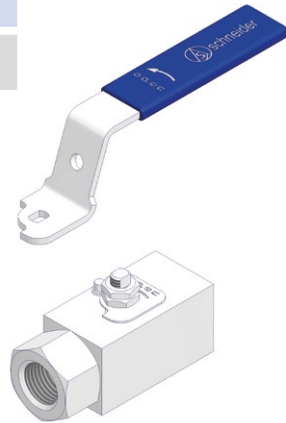

### Lockable Handle

Valves can be locked in either the open or closed position with a padlock (Option Code W). Lockable Handle incl. Padlock (Option Code U).

KA	KB	KC
available		

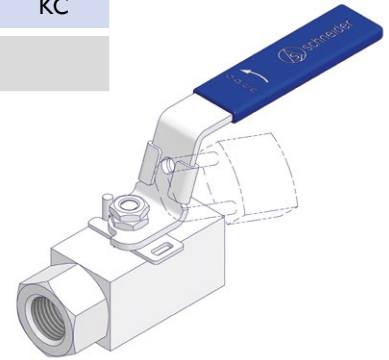

### Oval Handle

Oval Handle – Optional to standard lever type.  
(Option Code Q)

KA	KB	KC
available	-	



### Multi-Ported Ball Valve

Three ports of same size. (Option Code T)

KA	KB	KC
available	on request	



### Extended Body

Extended Body – Extended by approx. 60 mm (2.4") and a L1 of 115 (4.52") at KA, 128 (5.04") at KB and 145 (5.7") at KC Series. (Option Code E)

KA	KB	KC
available	on request	

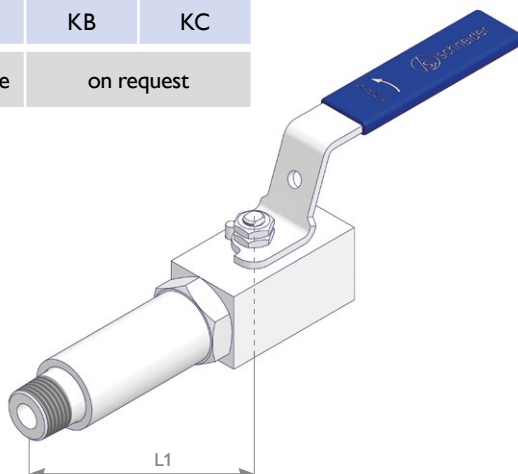

### Panel Mount

Valve can be mounted to panels up to a thickness of 6 mm (0.24") – Delivered with suitable bolts. (Option Code C)

KA	KB	KC
on request		



# KA, KB & KC Series I Ordering Information

## Ordering Information

				1	2	3	4	5	6	7	8	9	10	11	12	13	14	15	16	
				K	A	1	-	L	N	4	L	N	4	-	S	E	M			
KA	Ball Valve – Bore Size 10 mm																			
KB	Ball Valve – Bore Size 14 mm																			
KC	Ball Valve – Bore Size 20 mm																			
<b>Seal Material</b>																				
	<b>Available for</b>	<b>Packing</b>		<b>Ball Seat</b>																
1	KA	KB	KC	PTFE	Reinforced PTFE															
2	KA			Graphite	Reinforced PTFE															
3	KA	KB	KC	PTFE	PEEK															
4	KA			Graphite	PEEK															
<b>Inlet</b>				<b>KA Series only</b>																
<b>Thread Type</b>				<b>Fitting Type</b>																
LN	NPT Female			HK	Twin Ferrule Tube Fitting															
JN	NPT Male			TK	1/2 NPT Twin Ferrule Tube Fitting Male Connector															
JG	BSP Parallel (G) Male – EN837-1 (G 1/2 only)																			
<b>Thread Size</b>				<b>Fitting Size</b>																
2	1/4 – NPT only			3	10 mm															
4	1/2			4	12 mm															
6	3/4			8	3/8"															
8	1			9	1/2"															
<b>Outlet</b>																				
<b>Thread Type</b>				<b>Fitting Type</b>																
LN	NPT Female			HK	Twin Ferrule Tube Fitting															
JN	NPT Male			TK	1/2 NPT Twin Ferrule Tube Fitting Male Connector															
LM	Adjusting Nut BSP Parallel (G) Female – EN837-1 (G 1/2 only)																			
<b>Thread Size</b>				<b>Fitting Size</b>																
2	1/4 – NPT only			3	10 mm															
4	1/2			4	12 mm															
6	3/4			8	3/8"															
8	1			9	1/2"															
<b>Material   Body</b>																				
S	1.4401 / 1.4404 / 316 / 316L																			
F	Duplex UNS S31803																			
M	Alloy 400 UNS N04400																			
H	Alloy C-276 UNS N10276																			
<b>Options – Specify in alphabetical order</b>																				
B	Cleaned for Oxygen Service (on request)			E	Extended Body (other Series on request)															
C	Panel Mount (on request)			T	Multi Port Design (other Series on request)															
M	Wetted Parts with 3.1 Certificate			H	10,000 psi → Ball Seat in PEEK															
P	Pressure Test acc. to API 598																			
<b>Operation Options</b>																				
W	Lockable Handle			Q	Oval Handle															
U	Lockable Handle incl. Padlock			R	Loose Handle (other Series on request)															

Wetted Parts according to above mentioned material list are supplied according to NACE MR0175/MR0103 and ISO 15156 (latest issue).  
Note: Not every configuration which can be created in the ordering information is feasible / available.

# BA Series I Ball Valve Design

## Standard Ball Valve Design – Bore Size 10 mm (0.39")

### Features

- Floating Ball Design
- Ball Valve Seat:
  - Reinforced PTFE or
  - PEEK
- Ball Seats are encapsulated in end connector / body
- Stem Seal: Standard Packing in PTFE and Graphite
- Anti-Static Design as Standard acc. to ISO 17292
- Anti-Blowout Stem Design
- Seat Leakage Class VI acc. to ANSI/FCI 70-2
- Max. allowable (Working) Pressure (PS): 420 bar (6,092 psi) with PTFE and PEEK Seats → Bi-Directional
- Max. allowable (Working) Pressure (PS): 689 bar (10,000 psi) with PEEK Seats only → Uni-Directional
- Positive Stop Pins
- All Non-wetted Parts in 316 Stainless Steel

Note: Ball Valve Manifolds with Bore Size 14 / 20 mm available on request.

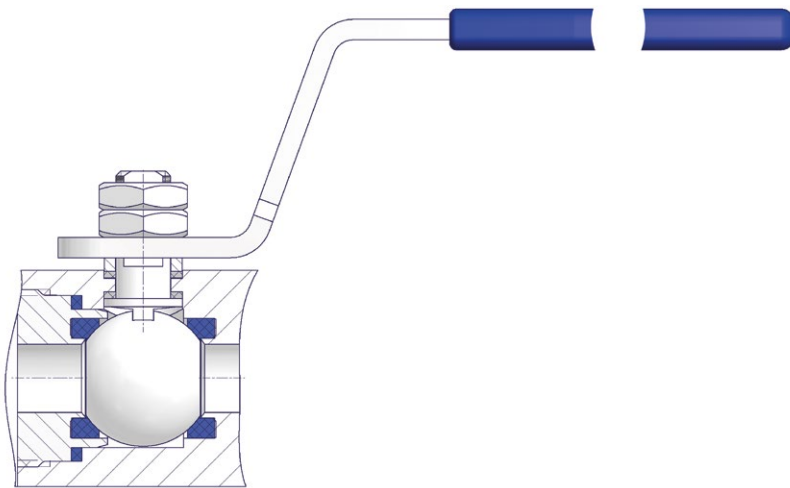

### Lockable Handle Design

Valves can be locked in either the open or closed position with a padlock (Option Code W). Lockable Handle incl. Padlock (Option Code U).

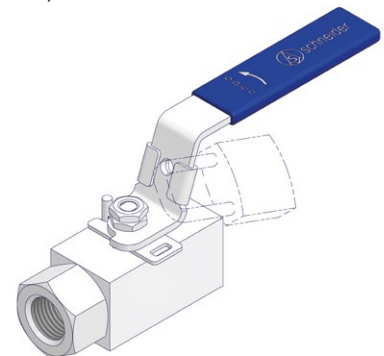

## Pressure-Temperature Ratings – Ball Valve

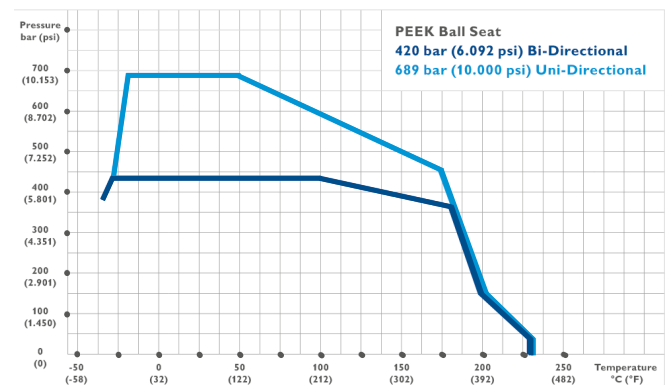
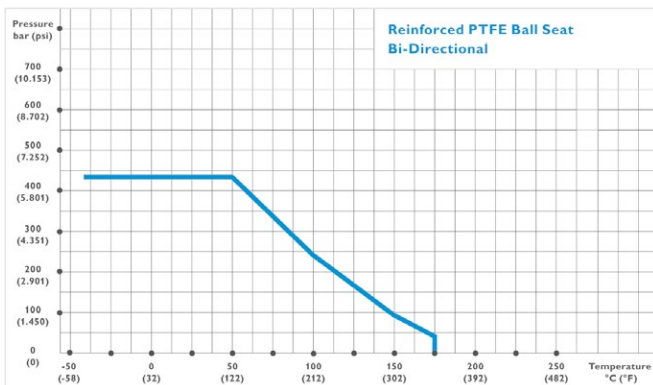

Note: Above-mentioned Pressure-Temperature Ratings are based on the standard material 316 stainless steel. Other materials as shown on page 18 might have different Pressure-Temperature Ratings.

### Low Temperature Limits:

- Seal Material: Ball Seat RPTFE -40°C
- Ball Seat PEEK -30°C

# BA Series I Block & Bleed Ball Valve Manifolds

## Block & Bleed Valves

The Double Block & Bleed Ball Valve Manifolds are combining a Primary Isolate Ball Valve and a choice of Ball or Needle Vent/Bleed Valve into one body for applications up to 10,000 psi (689 bar).

The standard end connections are 1/2 NPT, for further options please see ordering information on page 19 or contact the factory.

## Ball Valve Manifolds with Ball Pattern Isolate (Block) and Needle Pattern Vent

### Side Vent - Type BABA

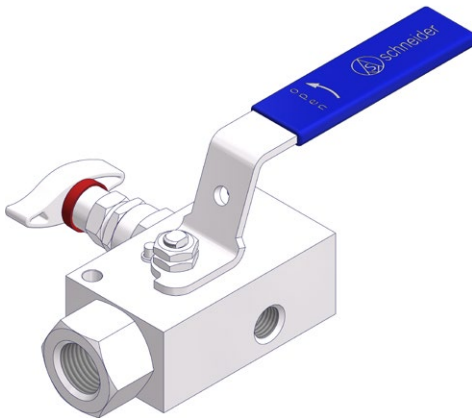

### Bottom Vent - Type BABD/BABC

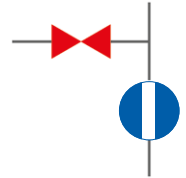
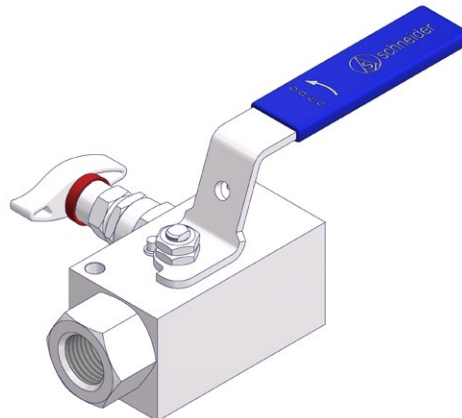

## Ball Valve Manifolds with Ball Pattern Isolate (Block) and Vent

### Type BACA/BACB

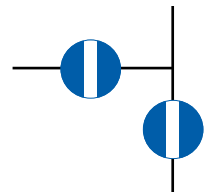
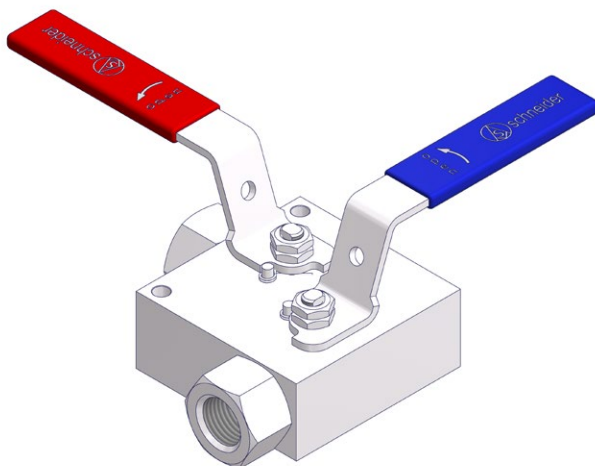

# BA Series I Double Block & Bleed Ball Valve Manifolds

## Double Block & Bleed Valves

The Double Block & Bleed Ball Valve Manifolds are combining a Primary and Secondary Isolate Ball Valve and a choice of Ball or Needle Vent/Bleed Valve into one body for applications up to 10,000 psi (689 bar). The standard end connections are 1/2 NPT, for further options please see ordering information on page 19 or contact the factory.

## Ball Valve Manifolds with Ball Pattern Isolate (Block) and Needle Pattern Vent

### Side Vent - Type BADA

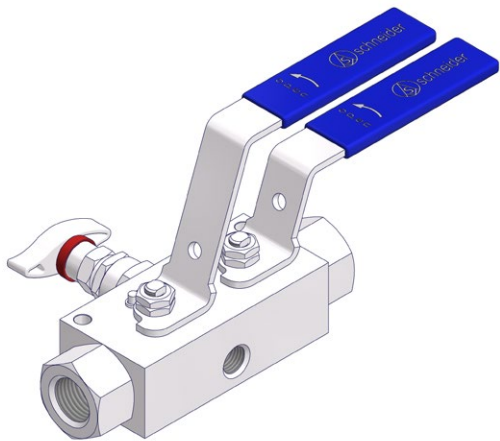

### Bottom Vent - Type BADD/BADC

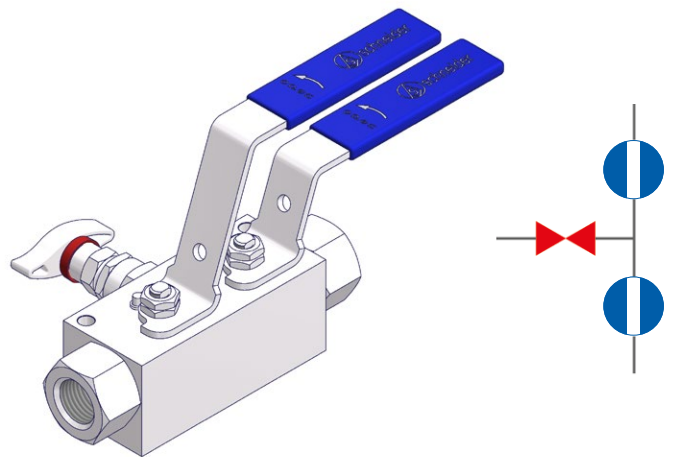

## Ball Valve Manifolds with Ball Pattern Isolate (Block) and Vent

### Type BAEA/BAEB

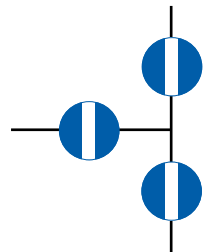
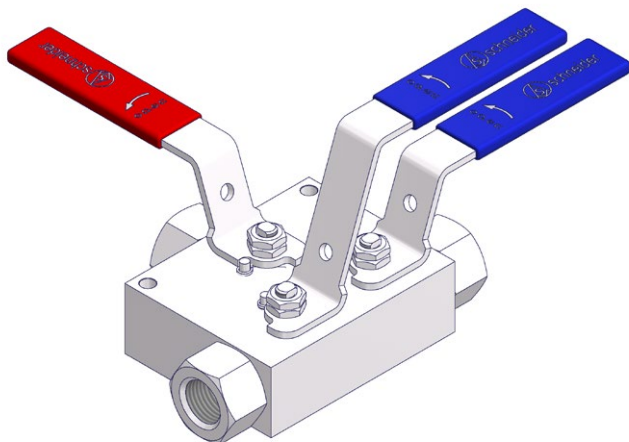

# BA Series I Needle Valve Design

## Standard Needle Valve Design – Bore Size 5 mm (0.197")

### Features

- Integral Valve Seat – Metal to Metal Seated
- Non-rotating Needle
- External Stem Thread – Packing below stem threads. Stem Threads are protected from process media (non-wetted, helps to prevent stems from galling)
- Stem with cold rolled threads
- Blow-out proof Needle
- Back Seat – Metal to Metal secondary needle seal
- Lock Pin – Eliminates unauthorized removal of the bonnet
- Color Coded Dust Cap for Operating thread protection
- Standard Packing in PTFE and Graphite available
- Max. allowable (Working) Pressure (PS):  
420 bar (6,092 psi)  
– 689 bar (10,000 psi) optional
- Anti-Tamper Valve Head Options available
- All non-wetted Parts in 316 stainless steel

### Standard Design 420 bar (6,092 psi)

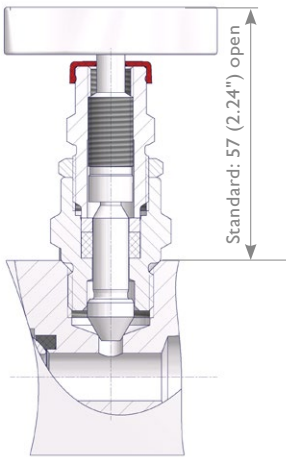

### High Pressure Design 689 bar (10,000 psi)

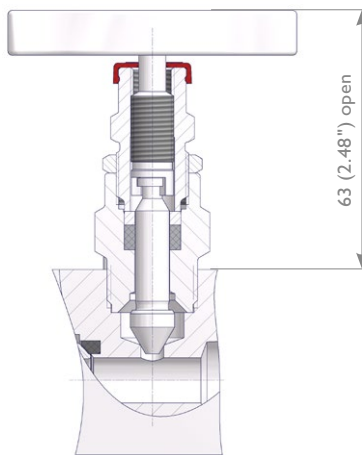

Body-to-Bonnet Seal is below the threads eliminating process fluid corrosion.

### Anti-Tamper Valve Head Unit

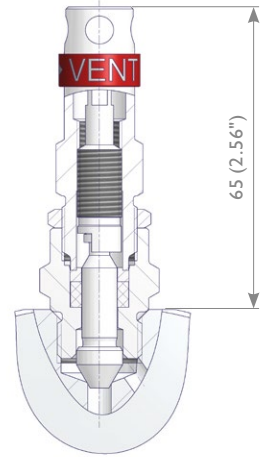

## Pressure-Temperature Ratings – Needle Valve

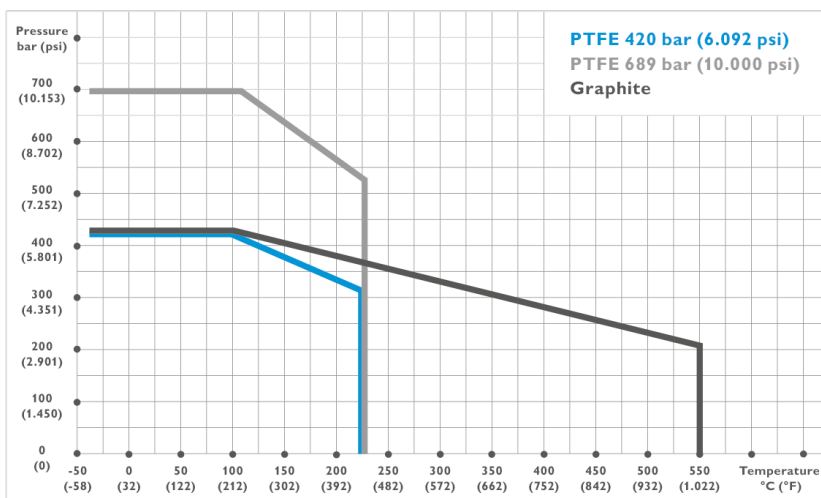

### Low-temperature Limits:

- PTFE and Graphite Packing: -40°C (-40°F)
- Carbon Steel ASTM A105: -29°C (20.2°F)

# BA Series I Double Block & Bleed Ball Valve Manifold Dimensions

## Ball Valve Manifolds with Ball Pattern Isolate (Block) and Needle Pattern Vent

### Side Vent - Type BADA

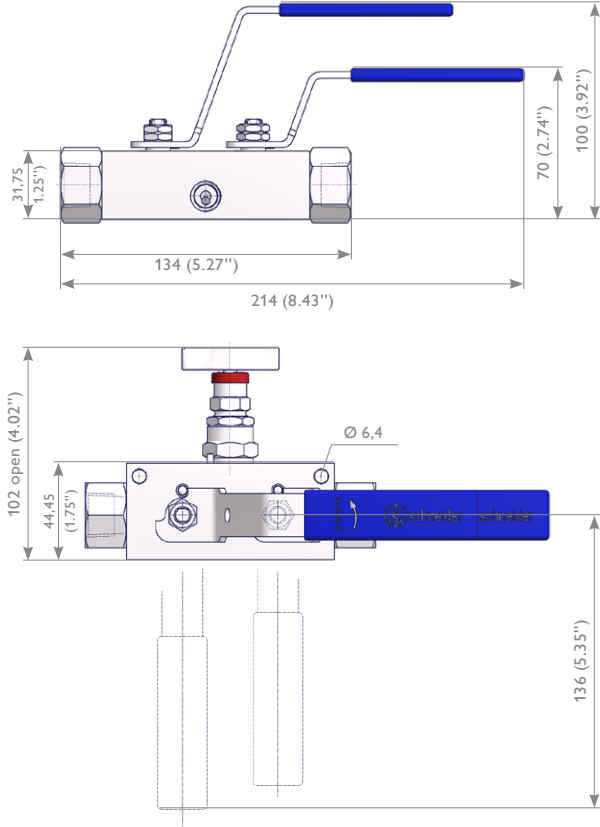

### Bottom Vent - Type BADD/BADC

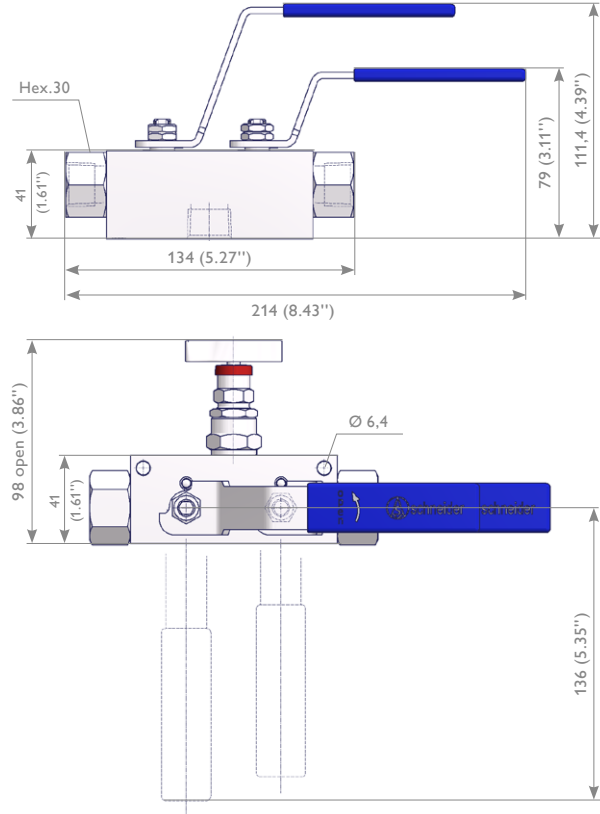

## Ball Valve Manifolds with Ball Pattern Isolate (Block) and Vent

### Side Vent - Type BAEA/BAEB

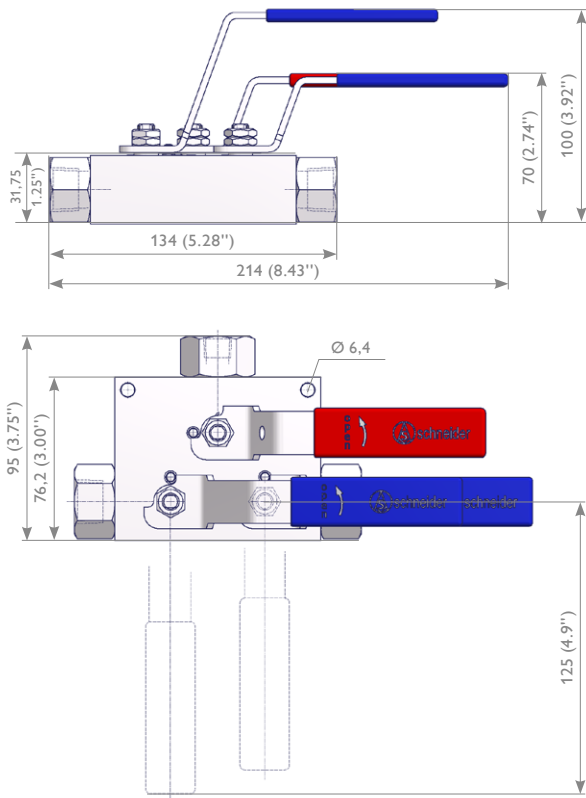

**Note:**  
Ball Valve Manifold Dimensions  
based on standard design 420 bar  
(6.092 psi)

# BA Series I Block & Bleed Ball Valve Manifolds Dimensions

## Ball Valve Manifolds with Ball Pattern Isolate (Block) and Needle Pattern Vent

### Side Vent - Type BABA

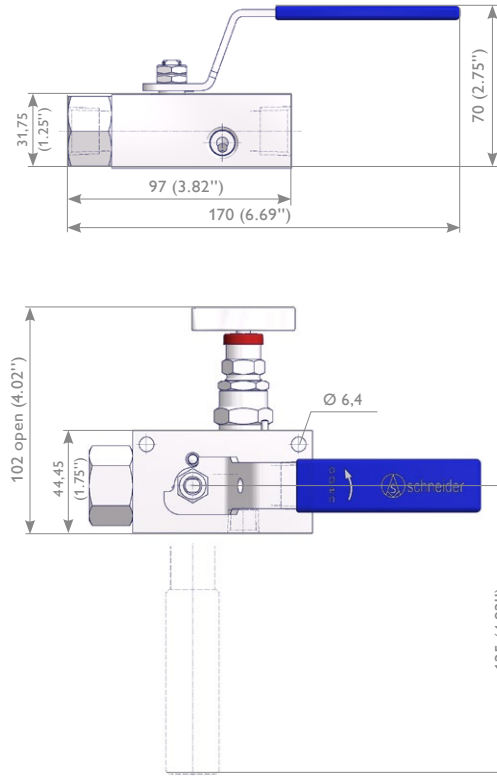

### Bottom Vent - Type BABD/BACC

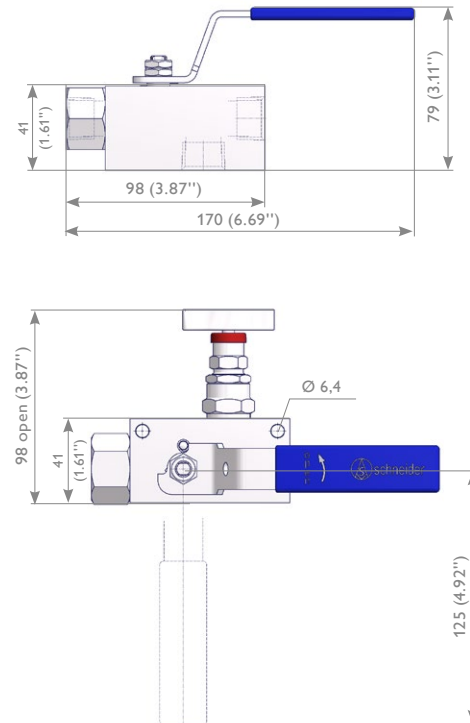

## Ball Valve Manifolds with Ball Pattern Isolate (Block) and Vent

### Type BACA/BACB

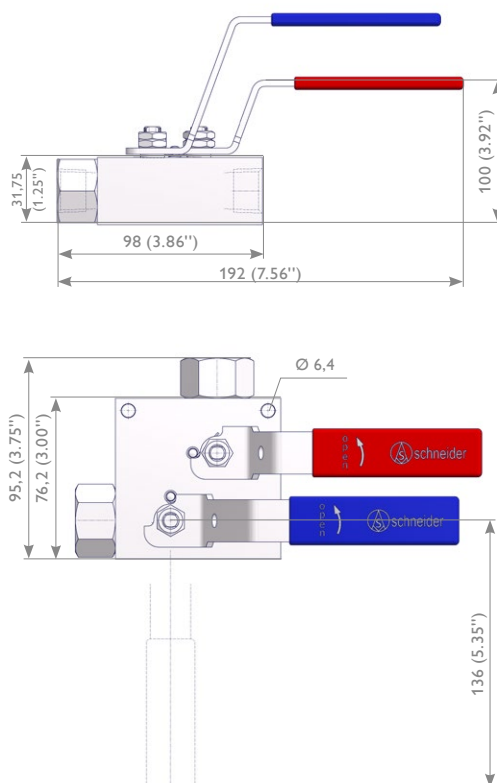

**Note:**  
Ball Valve Manifold Dimensions  
based on standard design 420 bar  
(6.092 psi)

# BA Series I Materials and General Features

## Materials

	Type	Components	Stainless Steel	Exotic Materials					
Wetted Parts	Ball Valve	Body	316/316L	Alloy 400	Alloy C-276	Duplex			
		Body End Connector							
		Ball							
		Stem							
		Ball Seat					Reinforced PTFE or PEEK		
		Body Seals					PTFE, Reinforced PTFE or Graphite		
	Needle Valve	Bonnet	316/316L	Alloy 400	Alloy C-276	Duplex			
		Needle							
		Packing					PTFE or Graphite		

All Non-wetted Parts in 316 Stainless Steel except Handle Grip in Vinyl

## General Features

### Sour Gas Service:

Wetted parts according to a.m. material list are supplied as standard according to NACE MR0175/MR0103 and ISO 15156 (latest issue).

### Pressure Test:

A shell test at 1.5 times the max. allowable (working) pressure and a seat leakage test are performed acc. to EN 12266-1 - P10, P11 and P12 respectively MSS-SP61 (and complies also with ASME B31.1 and B31.3) at every standard AS-Schneider Ball Valve Manifold → 100% Pressure Tested!

Pressure Test acc. to API 598 on request.

### Certification:

Certified Mill Test Report (CMTR) as Inspection certificate 3.1 acc. to EN 10 204 for valve body material and pressure test available on request.

PMI Test on request.

## Manufactured acc. to the following Codes and Specifications

- ASME B16.34 Valves – Flanged, Threaded and Welding End
- ASME B31.3 Process Piping
- ASME B31.1 Power Piping

# BA Series I Ordering Information

## Ordering Information

	1	2	3	4	5	6	7	8	9	10	11	12	13	14	15	16	17	18
	B	A	D	A	S	1	-	L	N	4	L	N	4	-	A			
<b>BA Ball Valve Manifold – Bore Size 10 mm</b>																		
<b>Type</b>																		
D	Double Block & Bleed   Ball x Ball x Needle																	
E	Double Block & Bleed   Ball x Ball x Ball																	
B	Block & Bleed   Ball x Needle																	
C	Block & Bleed   Ball x Ball																	
<b>Vent Connection</b>																		
<b>Size</b>	<b>Orientation</b>																	
A	1/4 NPT Female		Side Vent															
B	1/2 NPT Female		Side Vent ( Not for BAD/BAB Type)															
C	1/4 NPT Female		Bottom Vent (not for BAE/BAC Type)															
D	1/2 NPT Female		Bottom Vent (not for BAE/BAC Type)															
<b>Material</b>																		
S	316/316L																	
F	S31803 (Duplex)																	
M	Alloy 400																	
H	Alloy C-276																	
<b>Seal Material</b>																		
<b>Packing</b>	<b>Ball Seat</b>																	
1	PTFE		Reinforced PTFE															
2	Graphite		Reinforced PTFE															
3	PTFE		PEEK															
4	Graphite		PEEK															
<b>Inlet</b>																		
LN	NPT Female Thread																	
JN	NPT Male Thread																	
TK	1/2 NPT Female Thread c/w Twin Ferrule Tube Fitting Connector																	
<b>Thread Size</b>	<b>Fitting Size (for TK-Type)</b>																	
2	1/4"		3 10 mm															
3	3/8"		4 12 mm															
4	1/2"		8 3/8"															
6	3/4"		9 1/2"															
<b>Outlet</b>																		
LN	NPT Female Thread																	
JN	NPT Male Thread																	
TK	1/2 NPT Female Thread c/w Twin Ferrule Tube Fitting Connector																	
<b>Thread Size</b>	<b>Fitting Size (for TK-Type)</b>																	
2	1/4"		3 10 mm															
3	3/8"		4 12 mm															
4	1/2"		8 3/8"															
6	3/4"		9 1/2"															
<b>Options – Specify in alphabetical order</b>																		
A	Vent Port Plugged																	
M	Wetted Parts with 3.1 Certificate																	
P	Pressure Testing acc. to API598																	
H	10,000 psi → Ball seat in PEEK																	
<b>Operation Options*</b>																		
W	Lockable Handle																	
U	Lockable Handle Incl. Padlock																	

\* Option Code W and U: Needle Valve with Anti-Tamper Head Unit

# K Series I General Features

## K Series Ball Valves

AS-Schneider's K Series Ball Valves are very robust, forged ball valves which are designed especially for severe service for the chemical and petrochemical process industry. They Are especially used for close coupled hook-ups. End connector and valve body are full penetration welded for environmental protection.

Selection can be made from a comprehensive range of bodies with a variety of connections and material options, optimizing installation and access opportunities. Many of the types shown in this catalogue are available from stock or within a short period of time.

## Features

- Floating Ball Design – Bi-Directional
- 2 Piece Design – Fully Welded
- Forged Body in 1.0460 / A105 and 316
- Ball Bore Size 10 mm (0.39")
- Ball Seats are encapsulated in Seat Carrier
  - Material: PTFE or Carbon filled PTFE
- Stem Seal: PTFE or Graphite
- Max. allowable (Working) Pressure (PS): 250 bar (3,626 psi) | Class 1,500
- Anti-Blowout Stem Design
- Anti-Static Design
- Low Operation Torque
- Fire Safe tested acc. to ISO 10497 / API 607
- Wide Range of Connections available
- Pressure Test acc. to ISO 5208
  - Leakage Rate A acc. to ISO 5208
- Seat Leakage Class VI acc. to ANSI/FCI 70-2
- Materials comply to NACE MR 0175 / MR0103 / ISO 15156
- Ergonomic Oval Handles – Can be locked in opened and closed Position

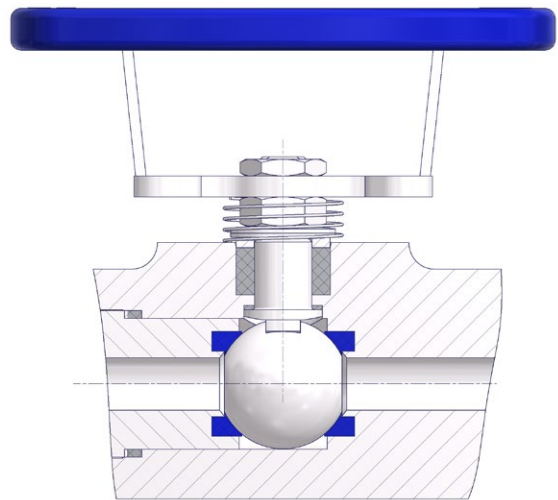

## Optional Features

- Fugitive Emission Bonnet – TA-Luft conformity optional
- Vented Ball
- Spring Loaded Ball Seat } Uni-Directional
- Ball Seat: PEEK, PCTFE and PFA
- Stellited Ball
- Padlock for Lockable Handle
- Extended Stem
- Cryogenic Applications tested acc. BS 6364
- Special Cleaning for Chlorine and Oxygen Service
- Optional Materials: ASTM A350-LF2, Alloy 400, Alloy C-276, Duplex, Etc.

For further Details, please contact the factory.

Components	Carbon Steel	Stainless Steel
	Material / Material No.	
<b>Body</b>	1.0460 / A105	F316 / F316L
<b>Body End Connector</b>		
<b>Ball</b>	316 / 316L	
<b>Stem</b>		
<b>Seat Carrier</b>	316 / 316L	
<b>Disc Spring</b>	Inconel 718	
<b>Primary Stem Seal</b>	Reinforced PTFE	
<b>Ball Seat</b>	PTFE or Reinforced PTFE	
<b>Packing</b>	PTFE or Graphite	
<b>Body Seals</b>		
Gland	316	
Hex Nut	300 Series	
Locking Plate		
Oval Handle		
Handle Grip	Vinyl	
Stop Screw	A2	

Wetted components listed in **bold**.

# K Series I Standard Ball Valve Design

## Standard Ball Valve Design

**Single-Ported Ball Valve** with following connections:

Inlet: Flanged, Threaded or Welded

Outlet: Threaded or Flanged

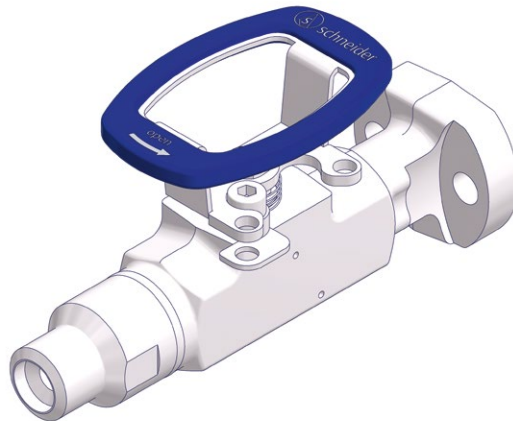
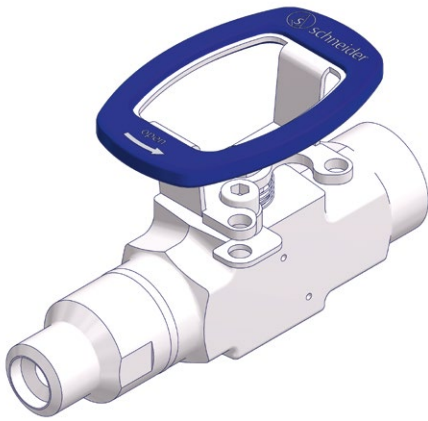

**Multi-Ported Ball Valve** with following connections:

Inlet: Flanged, Threaded or Welded

Outlet – Multiport Type: Threaded or Flanged & Threaded

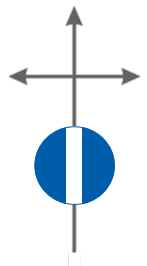
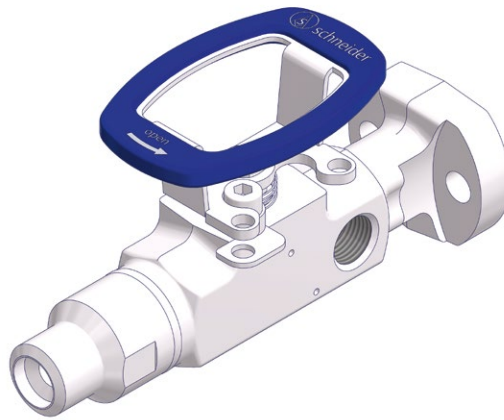
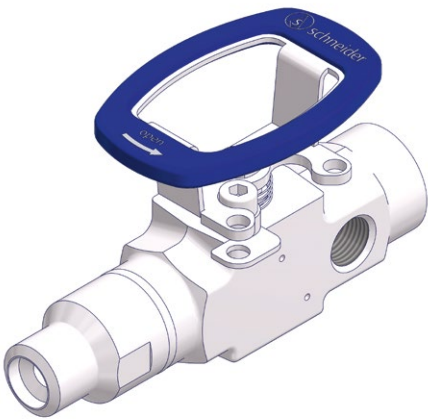

## Pressure-Temperature Ratings

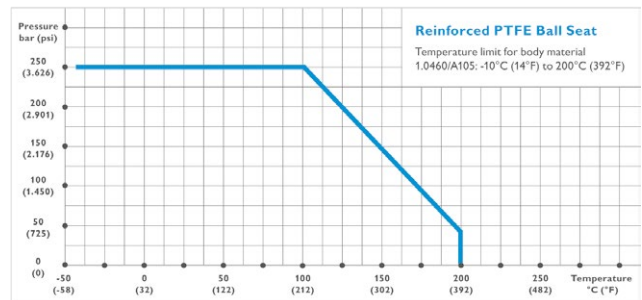
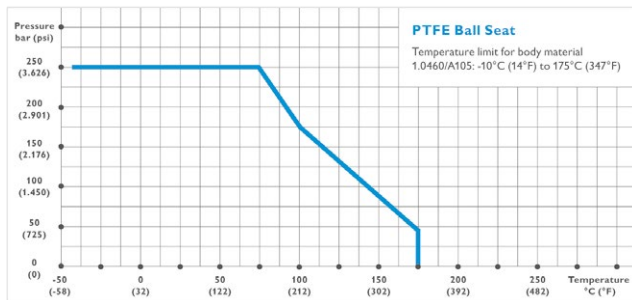

# K Series I Operation and Bonnet Options

## Short Handle

Similar in shape to the Standard oval handle but shortened by 18mm

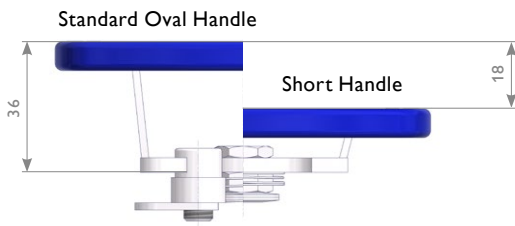

## Extended Handle



## Fugitive Emission Bonnet (FE Bonnet)

with lantern ring and threaded vent port

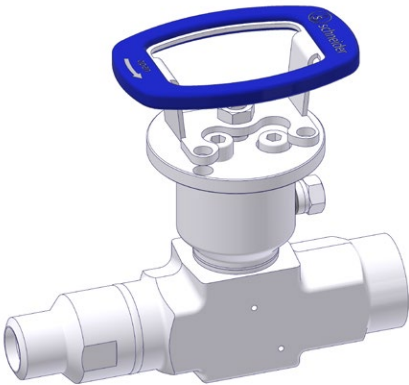

## Extended Bonnet for Cryogenic Service

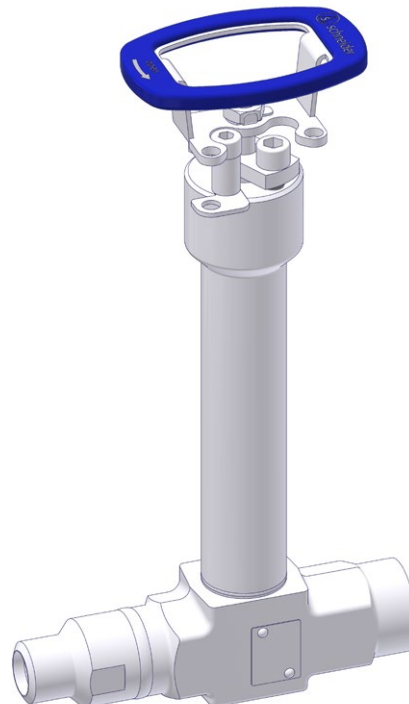

# K Series I Ordering Information

	1	2	3	4	5	6	7	8	9	10	11	12	13	14	15	16	17	18	19	20	21	22
	K	E	A	S	-	B	F	S	S	A	A	-	6	P	N	6	-	x	x	x	-	x
<b>K Ball Valve Fully Welded – Bore Size 10 mm</b>																						
<b>Rating</b>																						
D	Class 900																					
E	Class 1,500																					
<b>Bonnet</b>																						
A	Standard																					
F	Fugitive Emission Bonnet																					
<b>Ball / Ball Seat Design</b>																						
S	Standard (Bi-Directional)																					
V	Vented Ball (Uni-Directional)																					
<b>Inlet</b>																						
A	I-Flange																					
B	Butt Weld End																					
F	Female Thread																					
M	Male Thread																					
N	ASME Welding Neck Flange Sched.80																					
S	Socket Weld End																					
<b>Outlet</b>																						
A	I-Flange																					
B	Butt Weld End																					
F	Female Thread																					
M	Male Thread																					
S	Socket Weld End																					
<b>Material Body</b>																						
A	Alloy 20 UNS N08020																					
C	A105 / 1.0460																					
H	Alloy C-276 UNS N10276																					
L	ASTM A350 LF2																					
M	Alloy 400 UNS N04400																					
S	1.4404 / 1.4401 / 316 / 316L																					
<b>Material Ball</b>																						
A	Alloy 20 UNS N08020																					
H	Alloy C-276 UNS N10276																					
M	Alloy 400 UNS N04400																					
S	1.4404 / 1.4401 / 316 / 316L																					
<b>Material Packing</b>																						
A	PTFE																					
B	Graphite																					
W	TA-Luft																					
<b>Material Ball Seat</b>																						
A	PTFE																					
C	Carbon filled PTFE																					
F	PFA																					
K	PCTFE																					
P	PEEK																					
<b>Inlet</b>																						
<b>Thread Type</b>																						
N	NPT																					
<b>Butt Weld End</b>																						
4	1/2" pipe																					
6	3/4" pipe																					
8	1" pipe																					
<b>Socket Weld End</b>																						
4	For 1/2" pipe																					
6	For 3/4" pipe																					
<b>ASME Flange</b>																						
A	1/2" RF																					
C	1/2" RTJ																					
D	3/4" RF																					
G	1" RF																					
J	1" RTJ																					
K	1 1/2" RF																					
M	1 1/2" RTJ																					
N	2" RF																					
Q	2" RTJ																					
<b>Flange</b>																						
T	Flange Interface																					
<b>Inch Size</b>																						
2	1/4																					
3	3/8																					
4	1/2																					
6	3/4																					
8	1																					
<b>Wall Thickness BW</b>																						
N	Schedule 40																					
P	Schedule 80																					
Q	Schedule 160																					
A	For all SW																					
<b>ASME Flange</b>																						
A	Class 150																					
B	Class 300																					
C	Class 600																					
D	Class 900																					
E	Class 1500																					
Note: Class 2500 is too high for this ball valve																						
<b>Flange Interface</b>																						
A	Special Groove 25,5x21,3x1,2																					
D	EN 61518-A																					
E	EN 61518-B																					
<b>Outlet</b>																						
<b>Thread Size</b>																						
N	NPT																					
<b>Butt Weld End</b>																						
4	1/2" pipe																					
6	3/4" pipe																					
8	1" pipe																					
9	2" pipe																					
<b>Socket Weld End</b>																						
4	For 1/2" pipe																					
<b>Flange</b>																						
T	Flange Interface																					
<b>Inch Sizes</b>																						
2	1/4																					
3	3/8																					
4	1/2																					
6	3/4																					
8	1																					
<b>Wall Thickness BW</b>																						
N	Schedule 40																					
P	Schedule 80																					
Q	Schedule 160																					
A	Socket Weld																					
<b>Flange Interface</b>																						
A	Special Groove 25,5x21,3x1,2																					
D	IEC 61518-A																					
E	IEC 61518-B																					
<b>Options – Specify in alphanumerical order</b>																						
A	Extended Handle																					
B	Cleaned for Oxygen Service (O2)																					
D	Cleaned for Chlorine Service (CL2)																					
E	Extended Body																					
F	Cleaned for Ethylene Oxide Service (EO)																					
K	Cleaned for Isocyanate Service (ISO)																					
L	Handwheel Low																					
M	Wetted Parts with 3.1 certificate																					
P	Cleaned for Phosgene Service (PHS)																					
Q	P1 - Primer Coating (11-P1)																					
R	P3 - Finish Coating (11-P3)																					
T	Multiport 1/2NPT Female																					
W	Accessory kit - 2x 7/16-20UNFx1" ASTM A193 B8M Cl2; 1x seal ring																					
<b>Options – Instrumentation Hardware Sets*</b>																						
<b>Configuration (Outlet 1 x Outlet 2 x Outlet 3) - thread or flange interface specified in digit 15+16</b>																						
A	Thread x vent valve x plug																					
B	Plug x thread x vent valve																					
E	Flange interface x vent valve x plug																					
F	Plug x flange interface x vent valve																					
C	Thread x hand valve - seal welded x plug - seal welded																					
D	Plug - seal welded x thread x hand valve - seal welded																					
G	Flange interface x hand valve - seal welded x plug - seal welded																					
H	Plug - seal welded x flange interface x hand valve - seal welded																					
<b>Accessories</b>																						
None																						
None																						
2x 7/16-20UNFx1", ASTM A449 Type 1, 1x seal ring*																						
2x 7/16-20UNFx1", ASTM A449 Type 1, 1x seal ring*																						

Wetted Parts according to a.m. material list are supplied according to NACE MR0175/ MR0103 and ISO 15156/17945 (latest issue)

Note: Not every configuration which can be created in the ordering information if feasible / available.

\* More information you will find in our brochure AS-1601 - Instrumentation Hardware.

# KM Series I Metal Seated Ball Valves

## KM Series I Metal Seated Ball Valves

Extreme operating conditions with temperatures up to 450°C (842°F) and pressures up to 420 bar (6,092 psi) require special sealing technology in ball valves.

Standard Soft Seated Ball Valves simply aren't ready for this kind of requirements. Their plastic seals would fail. Metal Seated Ball Valves don't have this problem. However, most Metal Seated Ball Valves are not available for high pressures and also not available for smooth operation. AS-Schneider entered the Metal Seated Ball Valve arena with the KM Series.

When developing the KM Series AS-Schneider uses the latest surface and material knowledge combined with comprehensive engineering know-how. The result is a ball valve with zero leakage even under extreme operating conditions with respect to working pressure and temperature – even though a smooth operation is provided.

## Features

- 2 Piece Design – Fully Welded
- Ball Bore Size 10 mm (0.39")
- Seat and Ball Surfaces coated with Hardalloy and Carbide compounds
- 'Dissolution' Ball Valve Design and an outstanding axial bearing washer at the stem – For smooth operation (even at high working pressures)
- Double Sealing System in fugitive emission bonnet consisting of premium-quality graphite sealing rings
- Pressure Rating: Class 2,500
- Max. allowable Temperature (TS): -29°C (-20°F) to 450°C (842°F)
- Anti-Blowout Stem Design
- Can be locked in opened and closed position
- Oval Handle can be dismantled during operation
- Even Non-wetted Parts are made of 316 Stainless Steel for operation in corrosive environments
- Seat Leakage: ANSI / FCI 70-2 Class V
- Body Material: 1.4401 / 316 or LF2 / A105N
- Materials comply to NACE MR 0175 / MR0103 / ISO 15156
- Ball Valve meets requirements of TA-Luft (leak rate < 4,6 x 10<sup>-6</sup> mbar x l/s)
- Fire Safe tested acc. to ISO 10497 and API 607
- Design Basis: ISO 17292, ASME B16.34, MESC SPE 77/170, MESC SPE 77/110

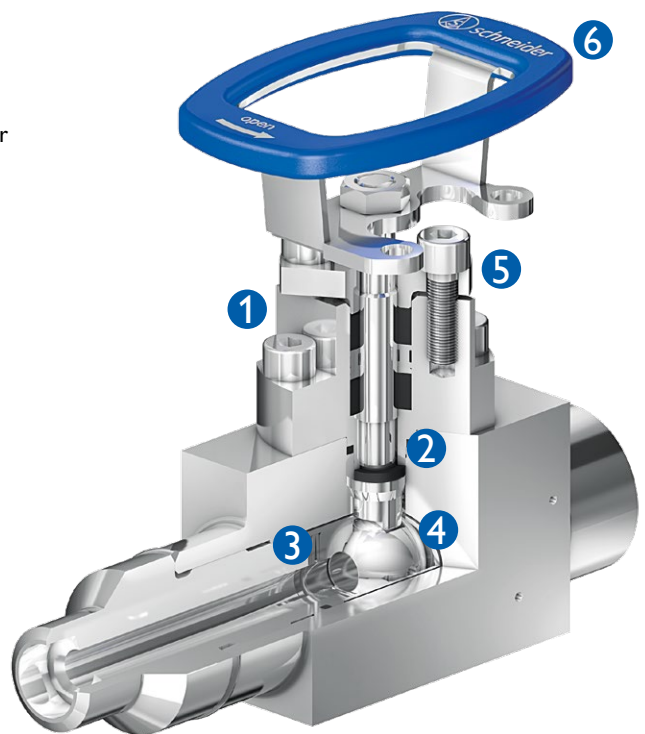

## Pressure-Temperature Rating

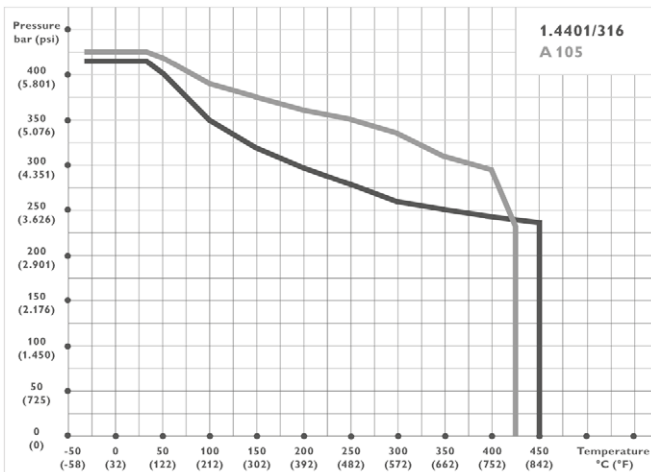

1. Fugitive Emission Bonnet with Double Sealing System and Lantern Ring
2. Outstanding Axial Bearing washer integrated at the Stem
3. Smooth Operation due to 'Dissolution' Ball Valve Design
4. Seat and Ball Surfaces coated with Hardalloy and Carbide compounds
5. Adjustment Capability for Packing with Gland Follower
6. Oval Handle can be dismantled during operation

# KM Series I Innovative 'Dissolution' Ball Valve Design

## Best tightness performance with maximum comfort

Large forces are required to preserve the tightness between ball and ball seats and the tightness between ball seats and valve body. These forces are often applied by a screw connector or when assembling the ball valve body (for example a three piece body).

In a conventional design, the transmission of force of the ball seat to valve body sealing is being effected directly by the ball, so as the pressure increases, the actuation torque also rises significantly. The max. allowable (Working) Pressure (PS) of Metal Seated Ball Valves from most manufacturers is thus about 100 bar – because this is the limit that still permits actuation of the valve.

With the 'Dissolution' Ball Valve Design, AS-Schneider has introduced an innovative solution. This patented design offers an optimum distribution of forces and loads in the valve, so they are only present where they are actually needed. The ball valve can thus be actuated without problems even under extreme conditions.



### Conventional Ball Valve Design

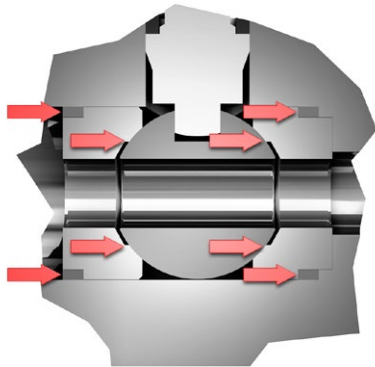

The forces required to maintain the tightness are stressing all components - even the ball and ball seats. The operating torque is thus very high.

### 'Dissolution' Ball Valve Design

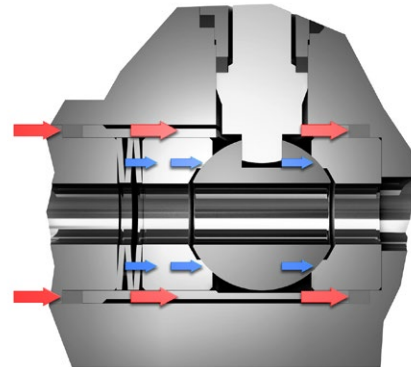

The forces needed to maintain the tightness between ball seat and valve body are only directed onto the corresponding graphite seal rings. The ball is only spring-loaded, which ensure a low, defined, minimum pressure off the balls on the ball seat. A smooth operation is the consequence.

# KM Series I Ordering Information

					1	2	3	4	5	6	7	8	9	10	11	12	13	14	15	16	17	18
					K	M	9	-	L	N	4	L	N	4	-	S	x	x	x	x	-	x
<b>KM Metal Seated Ball Valve Series</b>																						
<b>Seal Material</b>																						
<b>Packing</b>		<b>Ball / Seat</b>				<b>End Connector Seal Ring</b>																
9	Graphite	Coated 1.4401/316				Graphite																
<b>Inlet</b>																						
<b>Thread Type</b>		<b>Butt Weld End</b>				<b>Butt Weld End</b>				<b>Flange</b>												
LN	NPT	4	1/2" pipe			A	1/2" pipe			T Flange Interface												
		6	3/4" pipe			C	3/4" pipe															
		8	1" pipe			D	1" pipe															
		9	2" pipe			F	1/2" pipe															
		<b>Socket Weld End</b>		For 1/2" pipe		G	3/4" pipe															
		4				J	1" pipe															
						K	1/2" pipe															
						M	3/4" pipe															
						N	1" pipe															
						Q	1/2" pipe															
<b>Thread Size</b>		<b>Wall Thickness BW</b>				<b>1 Flange Interface</b>																
4	1/2	N Schedule 40				A Special Groove 25,5x21,3x1,2																
6	3/4	P Schedule 80				D IEC 61518-A																
		A <b>Socket Weld End</b>				E IEC 61518-B																
<b>Outlet</b>																						
<b>Thread Type</b>		<b>Butt Weld End</b>				<b>Flange</b>																
LN	NPT Female	A4 1/2" pipe				TD Acc. IEC 61518 - Type A																
LH	BSP Parallel (G) Female - DIN3852	A6 3/4" pipe																				
		A8 1" pipe																				
		<b>Socket Weld End</b>		For 1/2" pipe																		
				For 3/4" pipe																		
<b>Thread Size</b>		<b>Wall Thickness BW</b>				<b>1 Flange Interface</b>																
4	1/2	N Schedule 40				A Special Groove 25,5x21,3x1,2																
6	3/4	P Schedule 80				D IEC 61518-A																
		A <b>Socket Weld End</b>				E IEC 61518-B																
<b>Material Body   Ball and Ball Seat</b>																						
C	1.0460/A105 (Body)   1.4401/316 incl. coating (Ball and Ball Seat)																					
S	1.4401/316 (Body)   1.4401/316 incl. coating (Ball and Ball Seat)																					
<b>Options – Specify in alphabetical order</b>																						
B	Cleaned for Oxygen Service																					
E	Extended Body																					
M	Wetted Parts with 3.1 certificate																					
P	Pressure Testing acc. to API 598																					
T	Multiport Design - Three outlet ports of same size																					
U	Padlock for Lockable Handle																					
W	Accessory kit - 2x 7/16-20UNFx1", ASTM A193 B8M Cl. 2, 1x seal ring (material same as ball valve packing, either graphite or PTFE)																					
<b>Options - Instrumentation Hardware Sets</b>																						
<b>Configuration (Outlet 1 x Outlet 2 x Outlet 3) - thread or flange interface specified in digit 8 to 10</b>																						
A	Thread x vent valve x plug																<b>Accessories</b>					
B	Plug x thread x vent valve																None					
C	Thread x hand valve - seal welded x plug - seal welded																None					
D	Plug - seal welded x thread x hand valve - seal welded																None					
E	Flange interface x vent valve x plug																2x 7/16-20UNFx1", ASTM A449 Type 1, 1x seal ring*					
F	Plug x flange interface x vent valve																2x 7/16-20UNFx1", ASTM A449 Type 1, 1x seal ring*					
G	Flange interface x hand valve - seal welded x plug - seal welded																2x 7/16-20UNFx1", ASTM A449 Type 1, 1x seal ring*					
H	Plug - seal welded x flange interface x hand valve - seal welded																2x 7/16-20UNFx1", ASTM A449 Type 1, 1x seal ring*					
<small>* seal ring material same as ball valve packing, either graphite or PTFE</small>																						

Wetted Parts according to a.m. material list are supplied according to NACE MR0175/MR0103 and ISO 15156/17945 (latest issue)

Notes: Not every configuration which can be created in the ordering information is feasible / available.

## KM Series Ball Valve | Examples

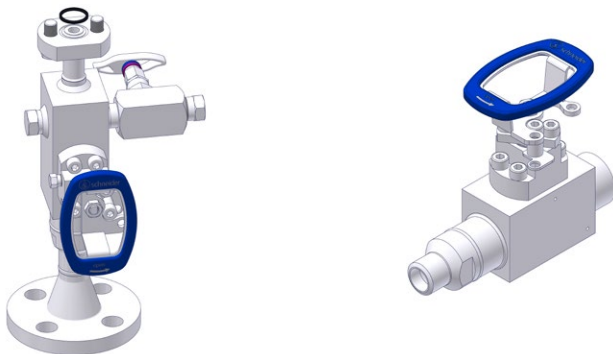

# Low Pressure Ball Valves 1,000 psi (69 bar)

## Features

- Floating Ball Design
- One Piece Design
- Reduced Bore
- Ball Valve Seat – PTFE
- Body and Stem: 316 Stainless Steel
- Stem Seal: PTFE
- Max. allowable (Working) Pressure (PS): 69 bar (1,000 psi)
- Anti-Blowout Stem Design
- Connections: Female NPT Threaded
- Test Standard: API 598
- Steam Rating: 125 psi (8.6 bar) WSP
- NACE MR0175 available
- 2 Handles are available:
  - Lockable Handle
  - Butterfly Handle

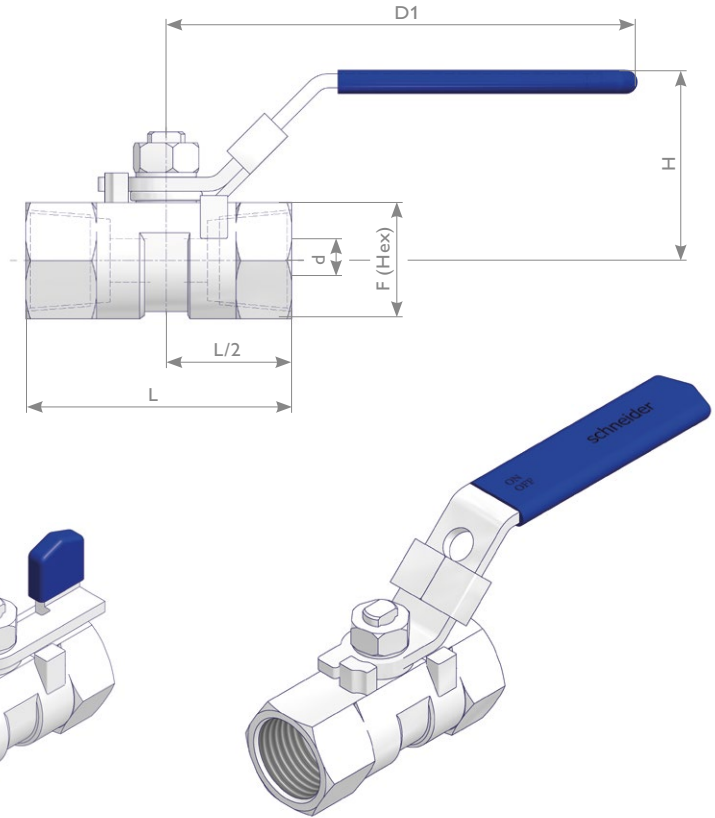

## Pressure-Temperature Rating

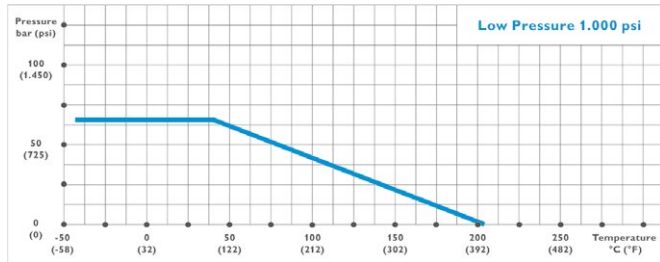

## Materials of Construction

Components	Material	Components	Material
Body	ASTM A351 Gr. CF8M	Packing	PTFE
Cap	ASTM A351 Gr. CF8M	Washer	304
Ball	ASTM A351 Gr. CF8M	Spring Washer	304
		Hexagon Nut	304
Stem	316	Handle	304
Ball Seat	PTFE	Handle Grip	Vinyl
Thrust Washer	PTFE	Locking Plate	304

## Ball Valve Dimensions

Size D	Handle Type	d		D1		W		F (Hex)		L		H		Part Number
		mm	inch	mm	inch	mm	inch	mm	inch	mm	inch	mm	inch	
1/4 NPT	Lockable Handle	5.0	0.20	66.0	2.60	51.0	2.00	17.0	0.67	39.0	1.54	31.0	1.22	520519
	Butterfly Handle											30.0	1.18	520731
3/8 NPT	Lockable Handle	7.0	0.28	76.0	3.00			21.0	0.83	44.0	1.73	35.0	1.38	521561
1/2 NPT	Lockable Handle	9.2	0.36	96.0	3.78	56.5	2.22	25.0	0.98	56.0	2.20	43.0	1.69	520594
	Butterfly Handle											34.0	1.34	520730
3/4 NPT	Lockable Handle	12.5	0.49	96.0	3.78			32.0	1.26	59.0	2.32	46.0	1.81	522008
1 NPT		16.0	0.63	110.0	4.33			38.0	1.50	71.0	2.80	50.0	1.97	522135

# YOUR GLOBAL PARTNER

for Instrumentation and  
Double Block & Bleed Valves



Visit us on:



ARMATURENFABRIK FRANZ SCHNEIDER GMBH + CO. KG  
World Headquarters  
Bahnhofplatz 12, 74226 Nordheim, Germany  
Tel: +49 7133 101-0  
[www.as-schneider.com](http://www.as-schneider.com)



ARMATURENFABRIK FRANZ SCHNEIDER SRL  
Gradinari 32-38, 100404 Ploiesti  
Romania  
Tel: +40 244 384 963  
[www.as-schneider.ro](http://www.as-schneider.ro)



AS-SCHNEIDER ASIA-PACIFIC PTE. LTD.  
970 Toa Payoh North, #02-12/14/15, Singapore 318992,  
Singapore  
Tel: +65 62 51 39 00  
[www.as-schneider.sg](http://www.as-schneider.sg)



AS-SCHNEIDER AMERICA, INC.  
17449 Village Green Dr, Houston, TX 77040  
United States of America  
Tel: +1 281 760 1025  
[www.as-schneider.com](http://www.as-schneider.com)



AS-SCHNEIDER MIDDLE EAST FZE  
P.O. Box 18749, Dubai  
United Arab Emirates  
Tel: +971 4 880 85 75  
[www.as-schneider.ae](http://www.as-schneider.ae)



AS-SCHNEIDER INDIA PRIVATE LIMITED  
Rathinam Techzone Campus, Eachanari  
641021 Coimbatore, Tamil Nadu, India  
Tel: +91 999 544 2201  
[www.as-schneider.com](http://www.as-schneider.com)

