

Instrumentation Products

Modular Mounting System



Introduction

Introduction

The AS-Schneider Group with its headquarters in Germany is one of the World's Leading Manufacturers of Instrumentation Valves and Manifolds. AS-Schneider offers a large variety of Modular Mounting Systems and Accessories needed for the instrumentation installations globally.

AS-Schneider's Modular Mounting System (MMS) provides substantial advantages by the simplest and most effective means to install Transmitters and Gauges. The MMS Series are designed to be compatible with the Shell® MESC Specifications for Process Instrumentation.

The MMS Components are designed to be used with Transmitters or Gauges for General Pressure and Differential Pressure Measurements. All components benefit from a compact design, reduced installation costs and less potential leak points.

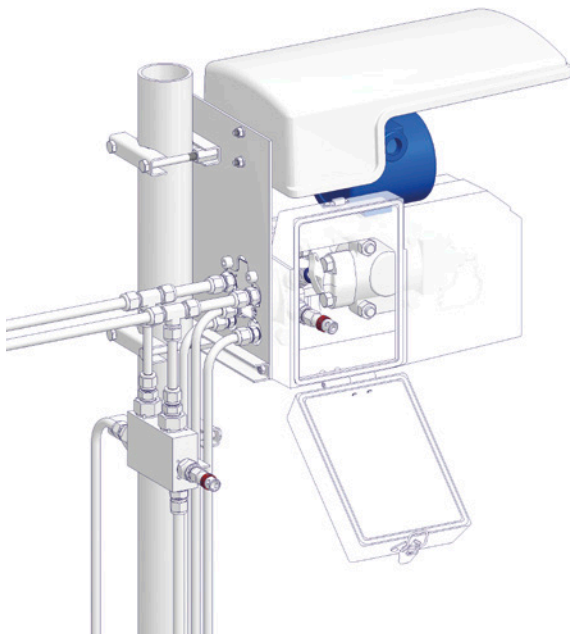

The MMS Components are Manifolds with a Choice of Accessories like:

- Mounting Brackets
- Single and Double Vent Purge Blocks
- Seal Pots
- Steam & Electrical Heaters
- Filling Connectors
- Blind Flanges
- Port Protectors
- Protective Shades and Enclosures
- Anti-Tamper Keys

Instrument Monoflanges for both Vertical and Horizontal Process Line Installations

Another important component is an Instrument Monoflange (Shell calls it Isolate/Vent Gauge Block).

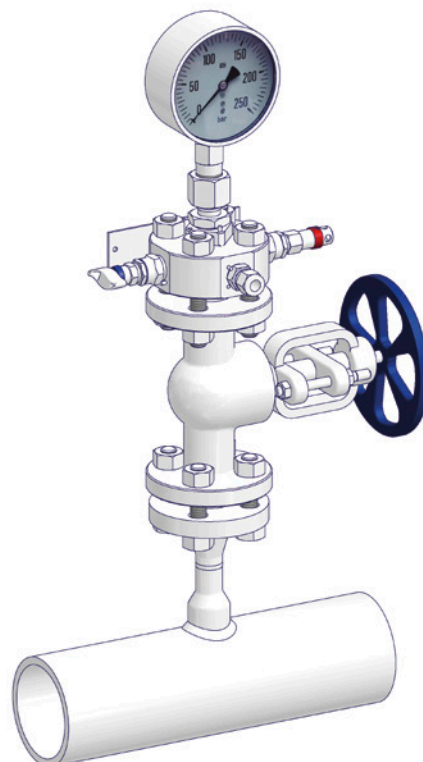

Introduction	page 2
Contents	page 3
General Features	page 4
Valve Head Units and Pressure-Temperature Ratings	page 5-6
SM Instrument Monoflanges	page 7-8
SB Manifolds	page 9-11
SAM Mounting Brackets	page 12
SVA Purge Blocks	page 13
SSB Seal Pots	page 14
SAS & SAE Heaters	page 15
SAF Filling Connectors	page 16
SAG Blind Flanges & Anti-Tamper Key	page 17
SAD Port Protectors & SAP Protective Shades and Enclosures	page 18
Cross Reference	page 19

Selection can be made from a comprehensive range of bodies with a variety of connections and material options, optimising installation and access opportunities.

Continuous product development may from time to time necessitate changes in the details contained in this catalogue. AS-Schneider reserves the right to make such changes at their discretion and without prior notice.

All dimensions shown in this catalogue are approximate and subject to change.

General Features

Body Material Options

Material Group	AS Material Designation	Material No.	Short Name	Equivalent UNS-No.	Material Grade acc. to ASTM	Manifolds, Monoflanges, Seal Pots, Filling Connectors, Blind Flanges and Port Protectors	Mounting Brackets, Steam Tracing Blocks and Purge Blocks
Austenitic Stainless Steel	316 quadruple certified*	1.4401	X5CrNiMo17-12-2	S31600	316	Standard	
		1.4404	X2CrNiMo17-12-2	S31603	316L		
Austenitic-Ferritic Stainless Steel	Duplex	1.4462	X2CrNiMoN22-5-3	S31803	F51	Optional	Not available
Nickel Based Alloys	Alloy 400	2.4360	NiCu30Fe	N04400			
	Alloy C-276	2.4819	NiMo 16 Cr 15 W	N10276			

* Quadruple certified means 316 / 316L / 1.4401 / 1.4404

Standard Features

- Bore Size 5 mm (0.197")
- Inlet and Vent Connection G 1/4 Female – DIN 3852-2
- Equalize and Vent Valves are equipped with an Anti-Tamper Head Unit – Anti-Tamper Head Unit Options see Page 5
- Suitable for Liquid and Gas Service
- Fully Self-draining

Needle Seal:

PTFE and Graphite Packings are available for all valve types.

Sour Gas Service:

Wetted parts according to a.m. material list are supplied as standard according to NACEMR0175/MR0103 and ISO 15156 (latest issue). However, valves in 316 and Duplex are equipped with a needle in Alloy 400.

Pressure Test:

A shell test and a seat leakage test are performed at 1.5 times the max. allowable (working) pressure acc. to EN 12266-1 - P10, P11 and P12 respectively MSS-SP61 (and complies also with ASME B31.1 and B31.3) at every standard AS-Schneider Monoflange → 100% Pressure Tested!

Certification:

Certified Mill Test Report (CMRT) as inspection certificate 3.1 acc. to EN 10 204 for valve body material and pressure test available on request.

Optional Features

- Special Design to be used with Rosemount 2051/3051 Coplanar™ Flange Transmitters
- Wide Range of Exotic Materials on request
- Connections can be assembled with Tube Fittings
- Special Connections on request
- Wide Choice of Manifold Configurations to suit your application

Fugitive Emission Application:

For Fugitive Emission Applications AS-Schneider is providing TA-Luft and ISO 15848 solutions. For more details see Page 6.

Oxygen Service:

AS-Schneider offers an option with Reinforced PTFE Packing cleaned and lubricated for Oxygen Service:

Pressure-Temperature Rating:

Max. 420 bar (6,092 psi) @ 60°C (140°F)

Max. 200°C (392°F) @ 90 bar (1,305 psi)

Not every Valve Type is available for Oxygen Service!

If you don't find your options in this catalogue, please contact the factory.

Standard Needle Valves

Screwed Bonnet – Needle Seal: Packing

Features

- Integral Valve Seat – Metal to metal seated
- Non-rotating Needle
- External Stem Thread – Packing below stem threads. Stem threads are protected from process media (non-wetted).
- Stem with Cold Rolled Threads
- Blow-out Proof Needle
- Back Seat – Metal to metal secondary needle seal
- Lock Pin – Eliminates unauthorized removal of the bonnet
- Color Coded Dust Cap for operating thread protection
- Standard Packing in PTFE and Graphite available
- Max. allowable (Working) Pressure (PS): 420 bar (6,092 psi)
- Anti-Tamper Valve Head Units for Equalize and Vent Valves
- All Non-wetted Parts in 316 Stainless Steel

Isolate Valve

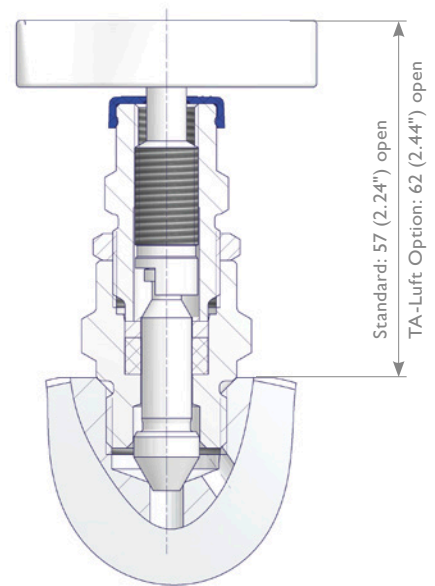

Equalize and Vent Valve

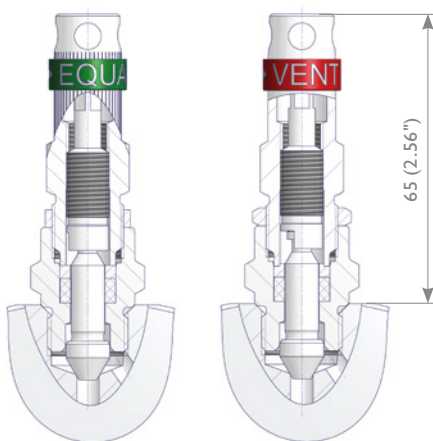

Anti-Tamper Key ATK-ES Type



Components	Stainless Steel	Exotic Alloys		
	Material / Material No.			
Body				
Bonnet				
Needle	316 / 316L	Alloy 400	Alloy C-276	Duplex
Plug				
Packing	PTFE or Graphite			
Valve Stem	316 / 316L			
Gland	316			
Stem Nut	316			
Lock Nut	316			
Set Screw	316			
T Handle	316			
Lock Pin	A4			

Wetted components listed in **bold**.

Color Coded Dust Cap For stem thread protection:

- Isolate BLUE
- Vent/Test RED
- Equalize GREEN

Color Coded Options Following options are also color coded below dust cap:

Oxygen Service



Graphite Packing



Fugitive Emission Applications and Pressure-Temperature Ratings

Needle Valves acc. to ISO 15848

Screwed Bonnet – Type 1 O-Ring Needle Seal + Graphite Packing
Type 3 PTFE Packing

Features

- Integral Valve Seat – Metal to metal seated
- Non-rotating Needle
- External Stem Thread – Packing below stem threads. Stem threads are protected from process media (non-wetted).
- Stem with Cold Rolled Threads
- Blow-out Proof Needle
- Back Seat – Metal to metal secondary needle seal
- Lock Pin – Eliminates unauthorized removal of the bonnet
- Color Coded Dust Cap for operating thread protection
- Needle Seal:
Standard Packing in PTFE or Graphite plus FKM O-Ring Needle Seal – RGD resistant (RGD = Rapid Gas Decompression)
- Max. allowable (Working) Pressure (PS): 420 bar (6,092 psi)
- Anti-Tamper Valve Head Options available
- All Non-wetted Parts in 316 Stainless Steel
- Types also comply with the requirements of TA-Luft 2002

ISO FE Performance Data

ISO FE Type 1:
Class A 1,500 cycles / -29°C to 40°C
(-20°F to 104°F)
Class A 500 cycles / -29°C to 200°C
(-20°F to 392°F)
Class B 1,500 cycles / -29°C to 200°C
(-20°F to 392°F)

ISO FE Type 3:
Class B 1,500 cycles / -29°C to 200°C
(-20°F to 392°F)

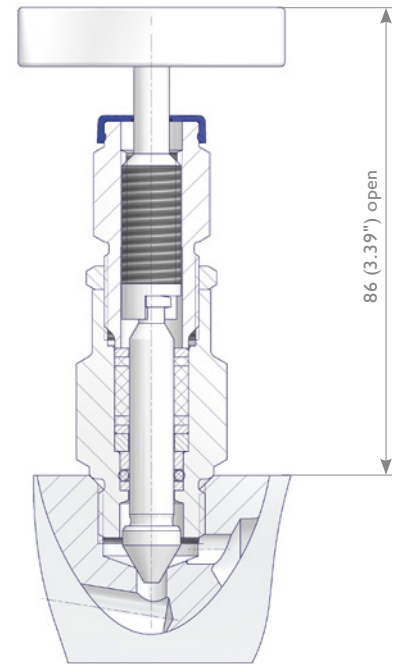

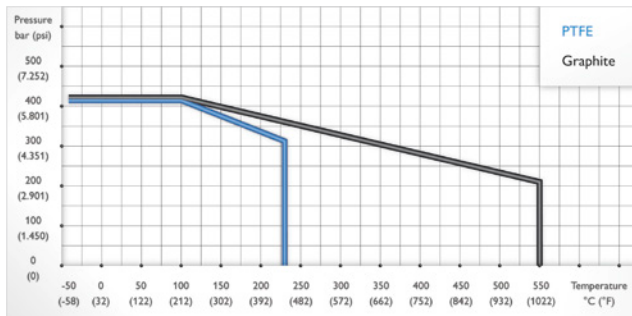

Pressure-Temperature Rating - Standard Valves



Above-mentioned Pressure-Temperature Rating is based on the standard material 316 stainless steel.

Other materials as shown on page 4 and 5 might have different Pressure-Temperature Ratings.

 **Packing adjustment may be required during the service life of the valves.**

 **Valves that have not been cycled for a period of time may have a higher initial actuation torque.**

Pressure-Temperature Rating - Valves acc. to ISO 15848

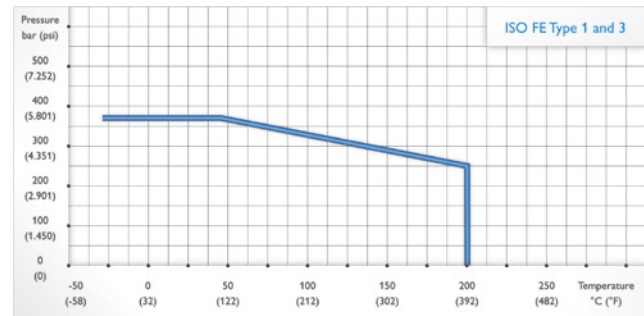

SM Instrument Monoflanges

The SM Instrument Monoflanges are Isolate / Vent Gauge Blocks for Pressure Gauges or Transmitters using screwed connections. The Gauge Connection is equipped with a Swivel Gauge Adaptor which enables the easy positioning of the gauge in any direction through 360°. It is suitable for Horizontal or Vertical Flange Mounting and can be assembled directly to the Primary Isolation Valve.

Connections

Instrument:
Swivel Gauge Adaptor with 1/2 NPT and G 1/2 Female Threads available. It can be supplied as an Integral Syphon Type.

Process:
1/2" Flange acc. to ASME B16.5
Available as LPR (150 – 600 lbs) and
HPR (900 – 2,500 lbs) RF Smooth Finish

Vent:
G 1/4 Female
Can be equipped with Compression Fittings

Pressure-Temperature Rating acc. to Shell MESC

Max. allowable (Working) Pressure (PS):
100 bar (1,450 psi) @ 38°C (100.4°F) (LPR 150 – 600 lbs)
413 bar (6,000 psi) @ 38°C (100.4°F) (HPR 900 – 2,500 lbs)

Max. allowable Temperature (TS): 200°C (392°F)

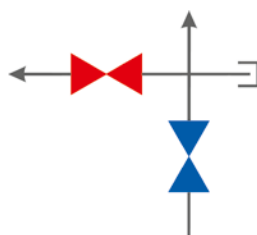

Instrument Monoflange

Type G

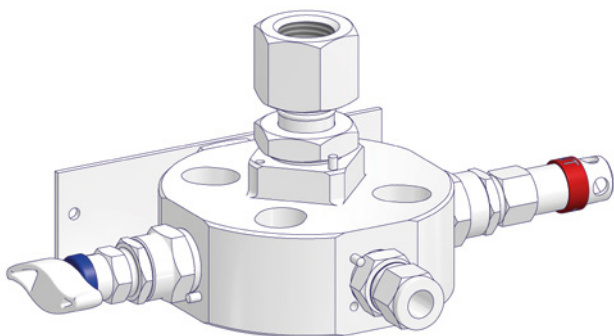

Instrument Monoflange

Type S

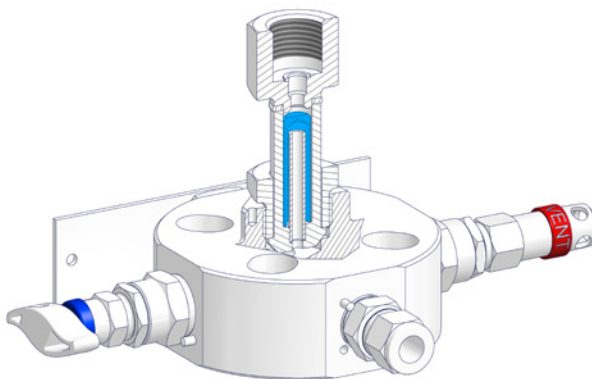

Ordering Code - Standard Monoflanges

MESC Code	Description	Vent	Part Number
MESC 60.98.55.200.1	Instrument Monoflange 1/2" 150 – 600 Type G	G 1/4-F	SMA-GLN-SG00
MESC 60.98.55.210.1	Instrument Monoflange 1/2" 900 – 2,500 Type G	G 1/4-F	SMA-GHN-SG00
MESC 60.98.55.220.1	Instrument Monoflange 1/2" 150 – 600 Type G	G 1/4-F	SMA-GLG-SG00
MESC 60.98.55.230.1	Instrument Monoflange 1/2" 900 – 2,500 Type G	G 1/4-F	SMA-GHG-SG00
MESC 60.98.55.300.1	Instrument Monoflange 1/2" 150 – 600 Type S	G 1/4-F	SMA-SLN-SG00
MESC 60.98.55.310.1	Instrument Monoflange 1/2" 900 – 2,500 Type S	G 1/4-F	SMA-SHN-SG00
MESC 60.98.55.320.1	Instrument Monoflange 1/2" 150 – 600 Type S	G 1/4-F	SMA-SLG-SG00
MESC 60.98.55.330.1	Instrument Monoflange 1/2" 900 – 2,500 Type S	G 1/4-F	SMA-SHG-SG00

SM Instrument Monoflanges

Ordering Information

	1	2	3	4	5	6	7	8	9	10	11	12	13	14
	S	M	A	-	G	L	G	-	S	G	0	0		
Instrument Monoflanges														
Packing														
A	PTFE													
B	Graphite													
L	ISO FE Series Type 1													
N	ISO FE Series Type 3													
Type														
G	Swivel Gauge Adaptor													
S	Swivel Gauge Adaptor with Integral Syphon													
Pressure Rating														
L	LPR (150, 300, 600 lbs)													
H	HPR (900, 1,500, 2,500 lbs)													
Thread														
G	G 1/2 Female													
N	1/2 NPT Female													
Material														
S	1.4401 / 1.4404 / 316 / 316L													
H	Alloy C-276 UNS N10276													
M	Alloy 400 UNS N04400													
F	Duplex UNS S31803													
Vent Connection														
G	G 1/4 Female													
B	1/4 NPT Female													
Tube Fitting														
0	Without Tube Fitting													
K	With Twin Ferrule Tube Fitting													
Size of Compression Fitting														
0	Without Compression Fitting													
3	10 mm													
4	12 mm													
8	3/8"													
9	1/2"													
Options (if available)														
B	Oxygen Service													
N	NACE / Sour Gas Service (Needle in Alloy 400)*													
T	Anti-Tamper Key													
Additional Options (if available)														
0	No additional Option													

* 316 SST Type includes NACE Option with Needle in 316 SST – Does not correspond to Shell MESC Spec.

SB Manifolds

The SB Manifold can be assembled directly to a Standard Mounting Plate, eliminating the need for extra Mounting Accessories and reducing pipe work on site. The SB Manifolds can also be supplied with a wide Choice of Accessories.

Pressure-Temperature Rating acc. to Shell MESC:

Max. allowable (Working) Pressure (PS): DIN 19213 400 bar (5,801 psi) @ 38°C (100.4°F)

IEC 61518 413 bar (6,000 psi) @ 38°C (100.4°F)

Max. allowable Temperature (TS): 200°C (392°F)

SB Manifolds for Differential Pressure Transmitters

Connections

Instrument – Flange Connection acc. to:

- DIN 19213 part 2 rev. 1980
- DN EN 61518 Type A
- Rosemount 2051/3051 Coplanar™ Pressure Transmitter (not specified in Shell MESC)

Process:

G 1/4 Female, 1/4 NPT or 1/2 NPT Female

Vent:

G 1/4 Female or 1/4 NPT Female

4 Valve Manifold – Type A

Double Isolate/Equalize/Vent Block

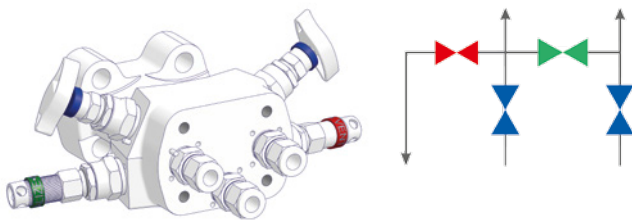

4 Valve Manifold – Type B

Double Isolate/Double Vent Block

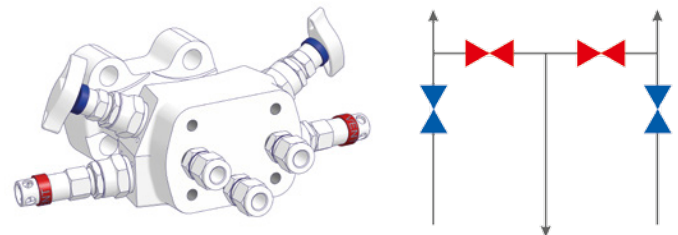

2 Valve Manifold – Type C

Single Isolate/Vent Block

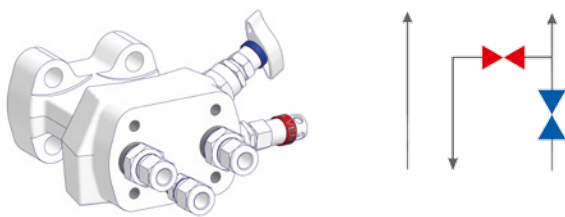

5 Valve Manifold – Type K

Double Isolate/Double Equalize/Vent Block

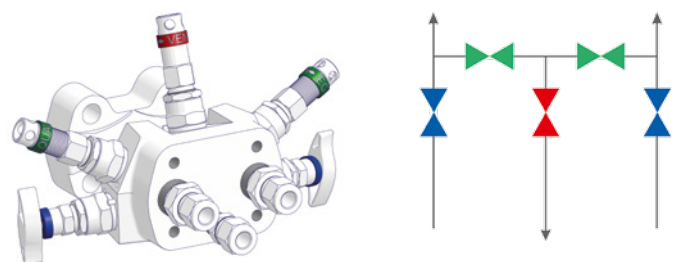

Ordering Code – Different Types for Different Applications

Type	MESC Code	Description	Vent	Part Number
A	MESC 60.98.56.2*105.1	4 Valve Manifold For general applications.	10 mm*2	SBA-AA0-SG*3
	MESC 60.98.56.2*107.1		3/8"*2	SBA-AA0-SG*8
B	MESC 60.98.56.2*115.1	4 Valve Manifold For applications where contamination of process stream is not permitted.	10 mm*2	SBA-BA0-SG*3
	MESC 60.98.56.2*117.1		3/8"*2	SBA-BA0-SG*8
C	MESC 60.98.56.2*125.1	2 Valve Manifold For pressure applications and level measurements on atmospheric tanks.	10 mm*2	SBA-CA0-SG*3
	MESC 60.98.56.2*127.1		3/8"*2	SBA-CA0-SG*8
K	Not specified in Shell MESC	5 Valve Manifold With Natural Gas Metering Pattern.	10 mm*2	SBA-KA0-SB*3
			3/8"*2	SBA-KA0-SB*8

*1 Manifolds with Transmitter Connection acc. to IEC 61518 and Seal Ring/Packing in Graphite = MESC 60.98.56.4###.1. See Cross Reference Page 19.

*2 Compression Fitting – Make, type, size and composition as specified in the requisition/indent.

Note: Direct Mount Manifolds according to MESC 60.98.56.2... are provided with PTFE Seal Ring / Packing. Manifolds with Graphite Seal Ring / Packing are according to MESC 60.98.56.4...!

SB Manifolds

SB Manifolds for Pressure Transmitters

Connections

Instrument:

Flange Connection acc. to:

- DIN 19213 part 2 rev. 1980
- DN EN 61518 Form A
- Rosemount 2051/3051 Coplanar™ Pressure Transmitter (not specified in Shell MES-C)

or Swivel Gauge Connector 1/2 NPT resp. G1/2

Process:

G 1/4 Female, 1/4 NPT or 1/2 NPT Female

Vent:

G 1/4 Female or 1/4 NPT Female

2 Valve Manifold – Type D

Single Isolate/Vent Block

Flange Connection DIN 19213

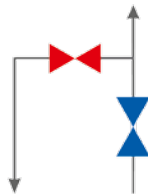
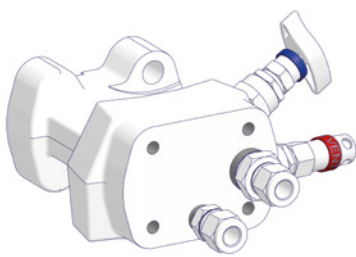

2 Valve Manifolds – Type E, F and G

with Swivel Gauge Adapter

see also below illustrations

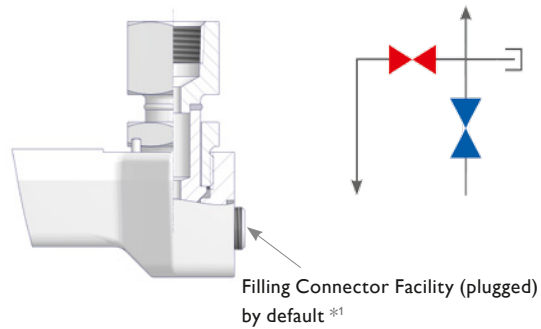

2 Valve Manifold – Type E

Single Isolate/Vent Block

Swivel Gauge Adaptor 1/2 NPT Male

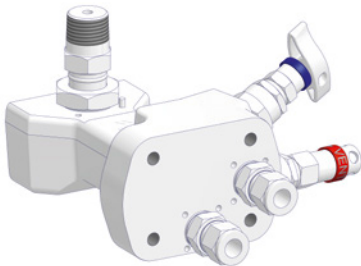

2 Valve Manifold – Type F

Single Isolate/Vent Block

Swivel Gauge Adaptor 1/2 NPT Female

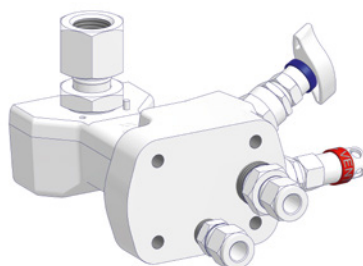

2 Valve Manifold – Type G

Single Isolate/Vent Block

Swivel Gauge Adaptor G 1/2 Female

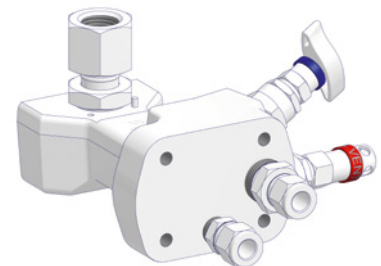

Ordering Code – Different Types for Different Applications

Type	MESC Code	Description	Vent	Part Number
D	MESC 60.98.56.2*235.1	2 Valve Manifold For pressure transmitters of the differential body design.	10 mm*3	SBA-DA0-SG*3
	MESC 60.98.56.2*237.1		3/8" *3	SBA-DA0-SG*8
E	MESC 60.98.56.305.1	2 Valve Manifold For pressure transmitters with 1/2 NPT Female connection.	10 mm*3	SBA-EA0-SG*3
	MESC 60.98.56.325.1		3/8" *3	SBA-EA0-SG*8
F	MESC 60.98.56.315.1	2 Valve Manifold For pressure transmitters with 1/2 NPT Male connection.	10 mm*3	SBA-FA0-SG*3
	MESC 60.98.56.335.1		3/8" *3	SBA-FA0-SG*8
G	MESC 60.98.56.317.1	2 Valve Manifold For pressure transmitters with G 1/2 Male (1/2 BSPP) connection.	10 mm*3	SBA-GA0-SG*3
	MESC 60.98.56.337.1		3/8" *3	SBA-GA0-SG*8

*1 If required, a Filling Connector can also be retrofitted. However, Filling Connectors to be ordered separately, see page 16.

*2 Manifolds with Transmitter Connection acc. to IEC 61518 and Seal Ring/Packing in Graphite = MESC 60.98.56.4###.1. See Cross Reference Page 19.

*3 Compression Fitting – Make, type, size and composition as specified in the requisition/indent.

Note: Direct Mount Manifolds according to MESC 60.98.56.2... are provided with PTFE Seal Ring / Packing. Manifolds with Graphite Seal Ring / Packing are according to MESC 60.98.56.4...!

Ordering Information

	1	2	3	4	5	6	7	8	9	10	11	12	13	14
	S	B	A	-	A	A	0	-	S	G	R	3		
Manifolds														
Packing														
A	PTFE													
B	Graphite (only if field 6 = C)													
L	ISO FE Series Type 1													
N	ISO FE Series Type 3													
Type														
A	Double Isolate / Equalize / Vent (General)													
B	Double Isolate / Vent (Anti-Contamination)													
C	Single Isolate / Vent (DP)													
D	Single Isolate / Vent (Pressure, DP Design)													
E	Single Isolate / Vent (1/2 NPT Male)													
F	Single Isolate / Vent (1/2 NPT Female)													
G	Single Isolate / Vent (G 1/2 Female)													
K	Double Isolate / Double Equalize / Vent Block (5 Valve Manifold)													
Transmitter Connection*1														
A	DIN 19213 Part 2 rev. 1980 or Threaded Type E, F and G with Swivel Gauge Adapter always 'A'													
B	Integral Style for Rosemount 2051/3051 Coplanar™ Pressure Transmitter (Type A, B, C and D only)													
C	DIN EN / IEC 61518 - Type A													
Material														
S	1.4401 / 1.4404 / 316 / 316L													
H	Alloy C-276 UNS N10276													
M	Alloy 400 UNS N04400													
F	Duplex UNS S31803													
Process / Vent Connection														
G	G 1/4 Female / G 1/4 Female													
B	1/2 NPT Female / 1/4 NPT Female													
C	1/4 NPT Female / 1/4 NPT Female													
Tube Fitting														
0	Without Tube Fitting													
K	With Twin Ferrule Tube Fitting													
Size of Compression Fitting														
0	Without Compression Fitting													
3	10 mm													
4	12 mm													
8	3/8"													
9	1/2"													
Options (if available)														
B	Oxygen Service (Not applicable for Purge Block)													
N	NACE / Sour Gas Service (Needle in Alloy 400)*2													
T	Anti-Tamper Key													
Additional Options (if available)														
0	No additional Option													

*1 Transmitter Connection:

A) DIN 19213: Type A, B, C, D and K are supplied with SST Hexagon Cap Screws 7/16-20 UNF x 1 1/2" and PTFE Seal Ring.

Threaded connection: 2 Valve Manifolds Type E, F and G with Swivel Gauge Adapter

B) Integral Style: No Bolts and Seal Rings are provided.

C) DIN EN / IEC 61518 Type A: Type A, B, C, D and K are supplied with SST Hexagon Cap Screws 7/16-20 UNF x 1 1/2" and Graphite Seal Ring, Packing is also Graphite. Alternatively with PTFE Seal Ring if Packing is also PTFE – This Option is not specified in Shell MESC.

*2 316 SST Type includes NACE Option with Needle in 316 SST – Does not correspond to Shell MESC Spec.

Note: 2 Valve Manifolds Type E, F and G are equipped with a Filling Connector Facility (plugged) by default. Means, if required, a Filling Connector can also be retrofitted. However, Filling Connectors to be ordered separately, see page 16.

SAM Mounting Brackets

SAM Mounting Brackets

The SAM Mounting Brackets are designed to ensure a Simple and Quick Installation of Manifolds with other Accessories including the Nameplate. There are four different types of Mounting Brackets available. The Brackets are made of 316 SST and are designed to be assembled to a 2" Pipestand. Type A is used, if a Protective Shade is required.

SAM-A1

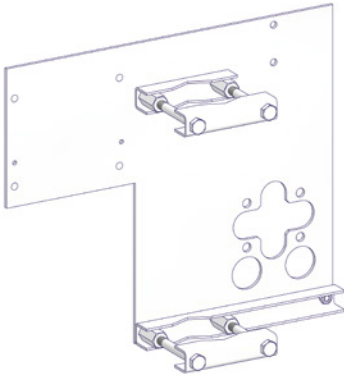

SAM-A2

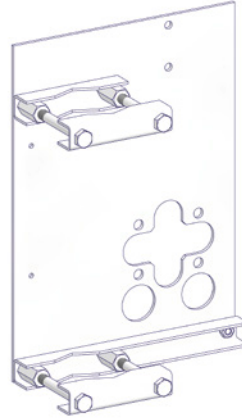

SAM-B1

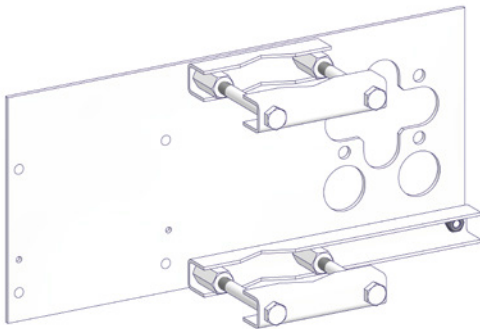

SAM-B2

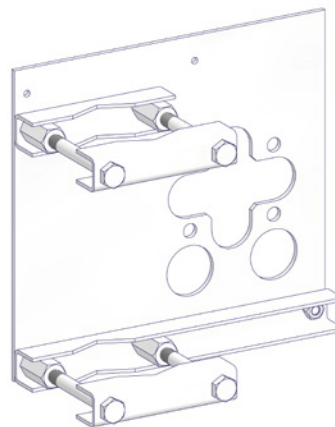

Ordering Code

MESC Code	Standard Drawing	Description	Part Number
MESC 60.98.91.105.1	37.813	Mounting Bracket A1	SAM-A1
MESC 60.98.91.110.1	37.815	Mounting Bracket A2	SAM-A2
MESC 60.98.91.118.1	37.814	Mounting Bracket B1	SAM-B1
MESC 60.98.91.120.1	37.816	Mounting Bracket B2	SAM-B2
	37.601	Stainless Steel Tag Plate	SAC-S00

SVA Purge Blocks

The SVA Purge Blocks have two main Applications:

1. Application:

Purge protection of the instrument using a purge medium to keep the process away from the instrument by maintaining a higher pressure than the process medium.

2. Application:

To provide a sensing medium for differential pressure instruments on level indication services.

There are two Vent Purge Blocks available, the Double Vent Purge Block SVA-D for differential pressure application and the Single Vent Purge Block SVA-S for static pressure applications.

Connections

Outlets:

Are equipped with Soft Seated Check Valves

Inlet:

Is provided with an Integral Filter

Pressure-Temperature Rating acc. to Shell MESC

Max. allowable (Working) Pressure (PS):
413 bar (6,000 psi) @ 38°C (100.4°F)

Max. allowable Temperature (TS):
• 200°C (392°F) for PTFE Packing and ISO FE Series Option

SVA-S00-SGS3

Single

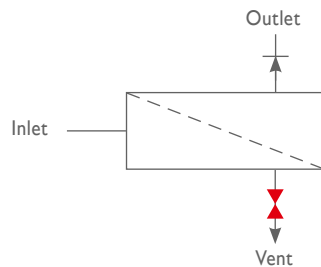
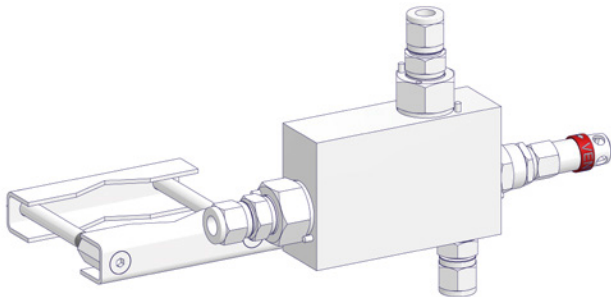

SVA-D00-SGS3

Double

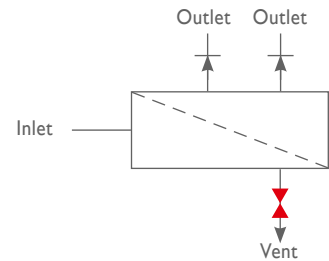
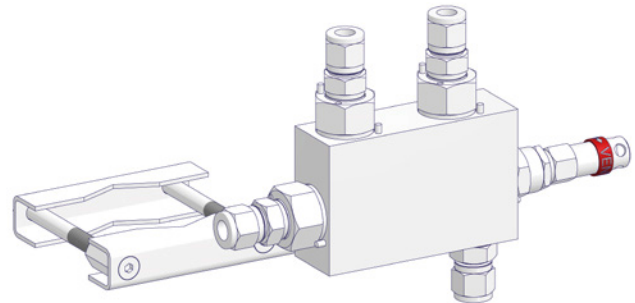

Ordering Code

MESC Code	Description	Vent	Part Number	Ordering Code, Field 3 & 9 – 14
MESC 60.98.70.210.1	Single Vent Purge Block Type S	10 mm*	SVA-S00-SG*3	See Page 11.
MESC 60.98.70.310.1		3/8"*	SVA-S00-SG*8	
MESC 60.98.70.220.1	Double Vent Purge Block Type D	10 mm*	SVA-D00-SG*3	
MESC 60.98.70.320.1		3/8"*	SVA-D00-SG*8	

* Compression Fitting – Make, type, size and composition as specified in the requisition/indent.

SSB Seal Pots

SSB Seal Pots

The SSB Seal Pots are used for systems requiring an open seal such as high temperature, toxic or corrosive service. The Seal Pots are used with an Immiscible Seal Fluid. The difference in density to the process media will provide a barrier in front of the Manifold and Instrument. Valve Head Units with Graphite Packing are used for SSB Seal Pots.

Location

Seal Pot is located below the Orifice Plate: A Seal Fluid with higher specific gravity than the Process Medium is to be used.

Seal Pot is located above the Orifice Plate: A Seal Fluid with lower specific gravity is to be used.

Pressure-Temperature Rating acc. to Shell MESC

Max. allowable (Working) Pressure (PS):
413 bar (6,000 psi) @ 38°C (100.4°F)

Max. allowable Temperature (TS):
450°C (842°F)

Volume

Approx. 50 cm³

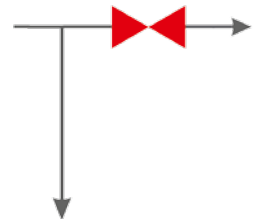
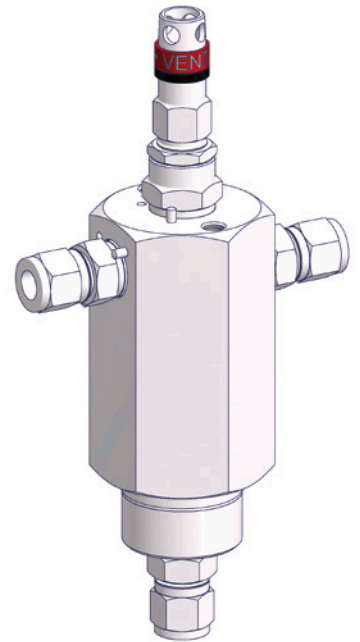

Ordering Code

MESC Code	Description	Vent	Part Number
MESC 60.98.70.510.1	Seal Pot	10 mm*	SSB-000-SG*3
MESC 60.98.70.600.1		1/2"*	SSB-000-SG*9
MESC 60.98.70.610.1		3/8"*	SSB-000-SG*8

* Compression Fitting – Make, type, size and composition as specified in the requisition/indent.

Ordering Information

1	2	3	4	5	6	7	8	9	10	11	12	13	14
S	S	B	-	0	0	0	-	S	G	R	3		
S	A	S											

Material	
S	1.4401 / 1.4404 / 316 / 316L
H	Alloy C-276 UNS N10276
M	Alloy 400 UNS N04400
F	Duplex UNS S31803
Process / Vent Connection	
G	G 1/4 Female / G 1/4 Female
C	1/4 NPT Female / 1/4 NPT Female
Tube Fitting	
0	Without Tube Fitting
K	With Twin Ferrule Tube Fitting
Size of Compression Fitting	
0	Without Compression Fitting
3	10 mm
4	12 mm
8	3/8"
9	1/2"
Options (if available)	
N	NACE / Sour Gas Service (Needle in Alloy 400)*
T	Anti-Tamper Key
Additional Options (if available)	
0	No additional Option

* 316 SST Type includes NACE Option with Needle in 316 SST – Does not correspond to Shell MESC Spec.

SAS & SAE Heaters

The SAS Steam Tracing Blocks & SAE Electrical Heaters are used to provide Frost Protection and to maintain Process Temperatures given that the heaters are mounted directly to the Manifold which ensures efficient Heat Transfer to the Manifold and Transmitter Body.

SAS Steam Tracing Blocks

Steam Tracing is provided through a separate Stainless Steel Block which is mounted directly to the Manifold with one Stainless Steel M8 Mounting Bolt.

The Connection to the Steam Line is provided by two G 1/4 (optional 1/4 NPT) Female Ports equipped with Tube Fittings.

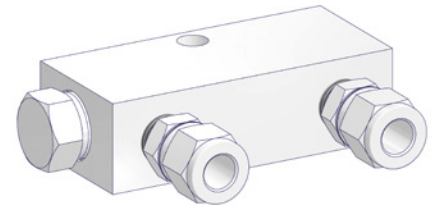

SAS Steam Tracing Blocks – Pressure-Temperature Rating acc. to Shell MESC

Max. allowable (Working) Pressure (PS):
20 bar (290 psi) @ 210°C (410°F)

Max. allowable Temperature (TS):
220°C (428°F)

SAE Electrical Heater

Conduction Heater with self-limiting output characteristic, supplied with cable length of 1m. Is directly mounted to the Manifold with one Stainless Steel M8 Mounting Bolt.

Material: Aluminum (sea water resistant)

Size: 90 x 40 x 30 mm

Voltage: 110 V to 265 V AC (50/60 Hz)

Rating: 50 W

Ingress Protection: IP68, NEMA 4X

Type of Protection (Gas): II 2 G Ex db IIC T4

Type of Protection (Dust): II 2 D Ex tb IIIC; T 135°C

EC Examination Certificate: PTB 02 ATEX 1116 X



Ordering Code

MESC Code	Description	Vent	Part Number	Ordering Code, Field 4 – 14
MESC 60.98.70.010.1	Steam Tracing Block	10 mm*	SAS-000-SG*3	See Page 14.
MESC 60.98.70.110.1		3/8"*	SAS-000-SG*8	
MESC 60.98.70.050.1	Electrical Heater		SAE	

* Compression Fitting – Make, type, size and composition as specified in the requisition/indent.

SAF Filling Connectors

SAF Filling Connectors

The SAF Filling Connectors are used if purge protection is required but no purge block is installed. The Filling Connector allows the system to be filled with Purge Medium through the instrument cavities. The Filling Connector has an integral Check Valve and is available with different connections.

Pressure-Temperature Rating acc. to Shell MESC

Max. allowable (Working) Pressure (PS):
DIN 19213 400 bar (5,801 psi) @ 38°C (100.4°F)
IEC 61518 413 bar (6,000 psi) @ 38°C (100.4°F)

Max. allowable Temperature (TS):
200°C (392°F)

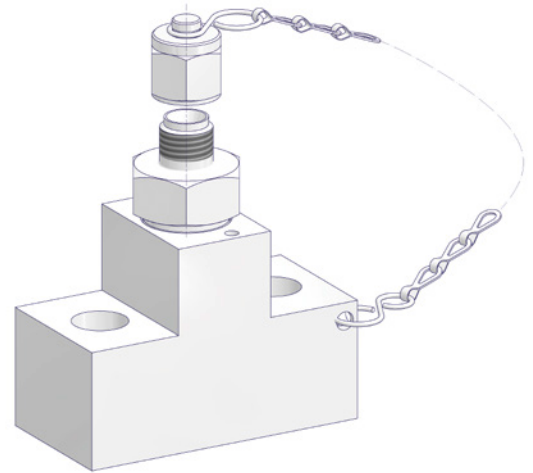

Ordering Code

MESC Code	Seal Ring/Packing	Description	Part Number
MESC 60.98.90.106.1	PTFE	Filling Connector 6 mm	SAF-A00-SP*1
MESC 60.98.90.406.1	Graphite		SAF-B00-SP*1
MESC 60.98.90.107.1	PTFE	Filling Connector 1/4"	SAF-A00-SP*7
MESC 60.98.90.407.1	Graphite		SAF-B00-SP*7

* Compression Fitting – Make, type, size and composition as specified in the requisition/indent.

Ordering Information

	1	2	3	4	5	6	7	8	9	10	11	12	13	14
	S	A	F	-	A	0	0	-	S	P	R	1		
Filling Connectors														
Seal Ring Material*														
A	PTFE													
B	Graphite													
Material Connector														
S	1.4401 / 1.4404 / 316 / 316L													
H	Alloy C-276 UNS N10276													
M	Alloy 400 UNS N04400													
F	Duplex UNS S31803													
Connection														
P	Cap with Chain													
Connection Type														
K	With Twin Ferrule Tube Fitting													
Size of Connection														
1	6 mm													
7	1/4"													
Options (if available)														
B	Oxygen Service													
N	NACE / Sour Gas Service													
Additional Options (if available)														
0	No additional Option													

* SAF is supplied with SST Hexagon Cap Screws 7/16-20 UNF x 1 1/2" and PTFE Seal Ring as standard. Flange Connection acc. to DIN 19213.
If a Graphite Seal Ring is specified, the Flange Connection will be acc. to DIN EN/IEC 61518 Type A.

SAG Blind Flanges & Anti-Tamper Key

SAG Blind Flanges

The Blind Flange enables standard instrument flange connections to be blanked off as required.

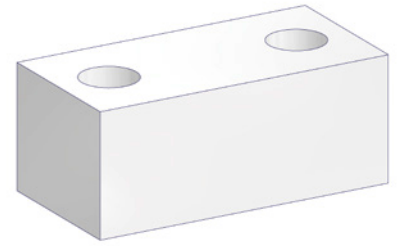

Ordering Information

	1	2	3	4	5	6	7	8	9	10	11	12	13	14
	S	A	G	-	A	0	0	-	S	0	0	0		
Blind Flanges														
Seal Ring Material*														
A	PTFE													
B	Graphite													
Material														
S	1.4401 / 1.4404 / 316 / 316L													
H	Alloy C-276 UNS N10276													
M	Alloy 400 UNS N04400													
F	Duplex UNS S31803													
Options (if available)														
B	Oxygen Service													
N	NACE / Sour Gas Service													
Additional Options (if available)														
0	No additional Option													

* SAG is supplied with SST Hexagon Cap Screws 7/16-20 UNF x 1 1/2" and PTFE Seal Ring as standard. Flange Connection acc. to DIN 19213.
If a Graphite Seal Ring is specified, the Flange Connection will be acc. to DIN EN/IEC 61518 Type A.

Anti-Tamper Key

Removable Anti-Tamper Key to operate the Anti-Tamper Vent Valves.

Part Number ATK-ES



SAD Port Protectors & SAP Protective Shades and Enclosures

SAD Port Protectors

The Port Protectors prevent the ingress of Bugs and Dirt.

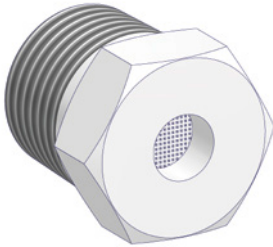

Ordering Information

	1	2	3	4	5	6	7	8	9
	S	A	D	-	G	2	0	-	S
Port Protectors									
Thread Type									
G	G								
N	NPT								
Thread Size									
2	1/4								
4	1/2								
Material									
S	1.4401 / 1.4404 / 316 / 316L								
H	Alloy C-276 UNS N10276								
M	Alloy 400 UNS N04400								
F	Duplex UNS S31803								

SAP Protective Shades and Enclosures

The SAP-P Protective Shades were designed to protect the Instrument from Heavy Rain and Intensive Sunlight.

The Enclosures provide a Complete Environmental Protection of the Manifold and the Instrument Body. They are mainly used if the System is exposed to Low Temperatures.

Ordering Code

MESC Code	Description	Part Number
MESC 60.98.91.205.1	Protective Shade G.R.P. Antistatic	SAP-PA0
	Protective Shade SST	SAP-PS0
MESC 60.98.91.305.1	Enclosure G.R.P. Antistatic	SAP-EA0

Protective Shade
SAP-PA0



Protective Shade
SAP-PS0



Enclosure
SAP-EA0

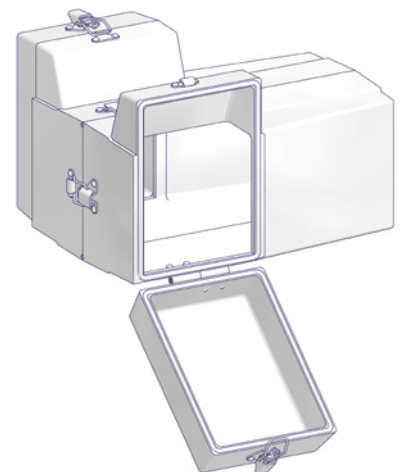

Cross Reference – Referring to the Global MESC Code

MESC Code	Description	Seal Ring/Packing	Vent	Part Number	Page
MESC 60.98.55.200.1	Instrument Monoflange 1/2" 150-600 Type G		G 1/4-F	SMA-GLN-SG00	7-8
MESC 60.98.55.210.1	Instrument Monoflange 1/2" 900-2,500 Type G			SMA-GHN-SG00	
MESC 60.98.55.220.1	Instrument Monoflange 1/2" 150-600 Type G			SMA-GLG-SG00	
MESC 60.98.55.230.1	Instrument Monoflange 1/2" 900-2,500 Type G			SMA-GHG-SG00	
MESC 60.98.55.300.1	Instrument Monoflange 1/2" 150-600 Type S			SMA-SLN-SG00	
MESC 60.98.55.310.1	Instrument Monoflange 1/2" 900-2,500 Type S			SMA-SHN-SG00	
MESC 60.98.55.320.1	Instrument Monoflange 1/2" 150-600 Type S			SMA-SLG-SG00	
MESC 60.98.55.330.1	Instrument Monoflange 1/2" 900-2,500 Type S			SMA-SHG-SG00	
MESC 60.98.56.205.1	4 Valve Manifold Type A	PTFE	10 mm*	SBA-AA0-SG*3	9-11
MESC 60.98.56.405.1		Graphite		SBB-AC0-SG*3	
MESC 60.98.56.207.1		PTFE	3/8"*	SBA-AA0-SG*8	
MESC 60.98.56.407.1		Graphite		SBB-AC0-SG*8	
MESC 60.98.56.215.1	4 Valve Manifold Type B	PTFE	10 mm*	SBA-BA0-SG*3	
MESC 60.98.56.415.1		Graphite		SBB-BC0-SG*3	
MESC 60.98.56.217.1		PTFE	3/8"*	SBA-BA0-SG*8	
MESC 60.98.56.417.1		Graphite		SBB-BC0-SG*8	
MESC 60.98.56.225.1	2 Valve Manifold Type C	PTFE	10 mm*	SBA-CA0-SG*3	
MESC 60.98.56.425.1		Graphite		SBB-CC0-SG*3	
MESC 60.98.56.227.1		PTFE	3/8"*	SBA-CA0-SG*8	
MESC 60.98.56.427.1		Graphite		SBB-CC0-SG*8	
MESC 60.98.56.235.1	2 Valve Manifold Type D	PTFE	10 mm*	SBA-DA0-SG*3	
MESC 60.98.56.435.1		Graphite		SBB-DC0-SG*3	
MESC 60.98.56.237.1		PTFE	3/8"*	SBA-DA0-SG*8	
MESC 60.98.56.437.1		Graphite		SBB-DC0-SG*8	
MESC 60.98.56.305.1	2 Valve Manifold Type E		10 mm*	SBA-EA0-SG*3	
MESC 60.98.56.325.1			3/8"*	SBA-EA0-SG*8	
MESC 60.98.56.315.1	2 Valve Manifold Type F		10 mm*	SBA-FA0-SG*3	
MESC 60.98.56.335.1			3/8"*	SBA-FA0-SG*8	
MESC 60.98.56.317.1	2 Valve Manifold Type G		10 mm*	SBA-GA0-SG*3	
MESC 60.98.56.337.1			3/8"*	SBA-GA0-SG*8	
MESC 60.98.91.105.1	Mounting Bracket A1			SAM-A1	12
MESC 60.98.91.110.1	Mounting Bracket A2			SAM-A2	
MESC 60.98.91.118.1	Mounting Bracket B1			SAM-B1	
MESC 60.98.91.120.1	Mounting Bracket B2			SAM-B2	
MESC 60.98.70.210.1	Single Vent Purge Block Type S		10 mm*	SVA-S00-SG*3	13
MESC 60.98.70.310.1			3/8"*	SVA-S00-SG*8	
MESC 60.98.70.220.1	Double Vent Purge Block Type D		10 mm*	SVA-D00-SG*3	
MESC 60.98.70.320.1			3/8"*	SVA-D00-SG*8	
MESC 60.98.70.510.1	Seal Pot		10 mm*	SSB-000-SG*3	14
MESC 60.98.70.600.1			1/2"*	SSB-000-SG*9	
MESC 60.98.70.610.1			3/8"*	SSB-000-SG*8	
MESC 60.98.70.010.1	Steam Tracing Block		10 mm*	SAS-000-SG*3	15
MESC 60.98.70.110.1			3/8"*	SAS-000-SG*8	
MESC 60.98.70.050.1	Electrical Heater			SAE	16
MESC 60.98.90.106.1	Filling Connector 6 mm	PTFE		SAF-A00-SP*1	
MESC 60.98.90.406.1		Graphite		SAF-B00-SP*1	
MESC 60.98.90.107.1	Filling Connector 1/4"	PTFE		SAF-A00-SP*7	
MESC 60.98.90.407.1		Graphite		SAF-B00-SP*7	
MESC 60.98.91.205.1	Protective Shade G.R.P. Antistatic			SAP-PA0	18
MESC 60.98.91.305.1	Enclosure G.R.P. Antistatic			SAP-EA0	

* Compression Fitting - Make, type, size and composition as specified in the requisition/indent.

YOUR GLOBAL PARTNER

for Instrumentation and
Double Block & Bleed Valves



Visit us on:



ARMATURENFABRIK FRANZ SCHNEIDER GMBH + CO. KG
World Headquarters
Bahnhofplatz 12, 74226 Nordheim, Germany
Tel: +49 7133 101-0
www.as-schneider.com



ARMATURENFABRIK FRANZ SCHNEIDER SRL
Gradinari 32-38, 100404 Ploiesti
Romania
Tel: +40 244 384 963
www.as-schneider.ro



AS-SCHNEIDER ASIA-PACIFIC PTE. LTD.
970 Toa Payoh North, #02-12/14/15, Singapore 318992,
Singapore
Tel: +65 62 51 39 00
www.as-schneider.sg



AS-SCHNEIDER AMERICA, INC.
17449 Village Green Dr, Houston, TX 77040
United States of America
Tel: +1 281 760 1025
www.as-schneider.com



AS-SCHNEIDER MIDDLE EAST FZE
P.O. Box 18749, Dubai
United Arab Emirates
Tel: +971 4 880 85 75
www.as-schneider.ae



AS-3601-EN | November 2020