

Instrumentation Products

Schneider DirectMount Systems



Introduction

Natural Gas Measurement - Best Practices

Field research and testing conducted by Southwest Research in San Antonio, Texas and the Pipeline Gas Compressor Research Council (PCRC) confirmed that pulsation created by compressors, flow control valves, regulators and some piping configurations may create undesirable levels of Square Root Error (SRE) and/or resulting Gauge Line Error (GLE). Pulsation at the orifice meter is a major source of lost and unaccounted for natural gas. These errors create large economic gains or losses for the buyer and seller along a natural gas pipeline system.

Conclusions determined that Transmitters or Electronic Flow Measurement (EFM) devices should be:

- Close coupled to the orifice taps (within 18 inches [460 mm] – "Rule of Thumb")
- Use equal length, large orifice (0.375 inch [9.5 mm] I.D. or greater), constant diameter gauge lines
- Use Multi-Turn Valves to protect electronics from pressure spikes

Minimize or eliminate Gauge Line Error (GLE): Schneider DirectMount Systems (SDMS) are designed for a safe, efficient method of close coupling EFM's and transmitters to the orifice fitting, eliminating or reducing the effects of Gauge Line Error.

SDMS are easy to install and available in both Vertical and Horizontal to Vertical Installations.

- SDMS reduces installation cost - No need to manufacture and install tube runs, fittings, and expensive pipe stands
- Reduces potential leak points associated with NPT connections
- Provides a safe compact leak free measurement installation
- Internal porting promotes self draining of condensates and liquids to reduce freezing issues

Design Standards meet the Recommendations of:

- American Petroleum Institute (API)
- Gas Processors Association (GPA)
- American Gas Association (AGA)
- Bureau of Land Management (BLM)

Long-term Confidence and Commitment: You can rest assured in your decision to purchase AS-Schneider – we are a modern, international family-owned company since 1875. You can rely on our 140 years of manufacturing experience. The AS-Schneider Group with its headquarters in Germany is one of the world's leading manufacturers of Instrumentation Valves and Manifolds. Our USA office and warehouse located in Houston Texas is committed to providing excellent service to our customers in the Americas.

Continuous product development may from time to time necessitate changes in the details contained in this catalogue. AS-Schneider reserves the right to make such changes at their discretion and without prior notice.

All dim

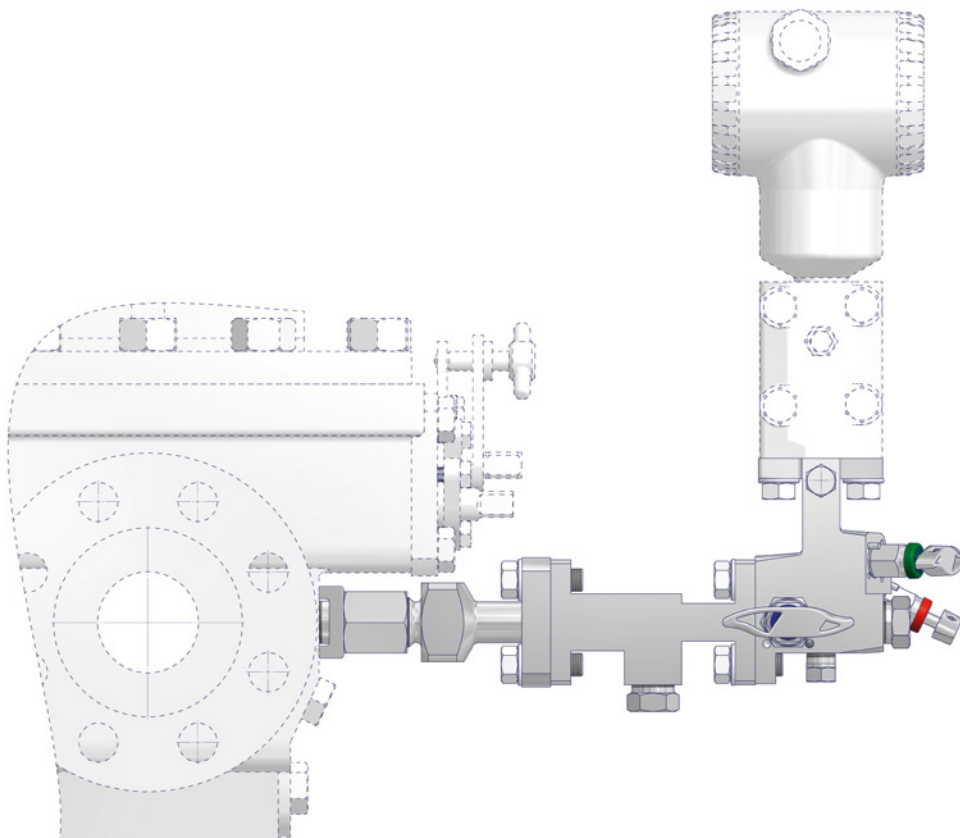

Introduction	page 2
Contents	page 3
General Features	page 4
Features and Benefits	page 5
Valve Head Unit / Bonnet Options	page 6-7
Stabilized Connectors and Spacers	page 8-9
Spacers and 2 Valve Manifolds	page 10
5 Valve Manifolds	page 11-13
Universal Flange Interface (MSS SP-99 / IEC 61518)	page 11-13
Adapters	page 14-15
Horizontal Installation	page 16
Vertical Installation	page 17
Manifolds for Ultrasonic Flow Meter Applications	page 18
Spare Parts	page 19

General Features

Body Material Options

Material Group	AS Material Designation	Material Grade acc. to ASTM	Equivalent UNS-No.	Material No.	Short Name	Stabilized Connectors	Spacers	Manifolds	Adapters
Carbon Steel	Carbon Steel	A105				Standard	Standard	Standard	Standard
Austenitic Stainless Steel	316 quadruple certified*	316	S31600	1.4401	X5CrNiMo17-12-2	Standard	Standard	Standard	Standard
		316L	S31603	1.4404	X2CrNiMo17-12-2				
Nickel Based Alloys	Alloy 400		N04400	2.4360	NiCu30Fe	Optional	Optional	Optional	Optional
	Alloy C-276		N10276	2.4819	NiMo 16 Cr 15 W	Optional	Optional	Optional	Optional

* Quadruple certified means 316 / 316L / 1.4401 / 1.4404

Standard Features

- Bore Size
 - Isolate Valves: 3/8" (9.5 mm)
 - Equalize and Vent Valves: 0.138" (3.5 mm)
- Soft Seat
 - Isolate Valves: Cone Design (roddable)
 - Equalize and Vent Valves: Cup Design
 - Soft Seats are field replaceable
- Double O-Ring Design as standard
- PTFE Packing is also available for all valve types
- 5 Valve Manifolds are supplied with a bug plug in the 1/4 NPT female vent port (fitted)

Sour Gas Service:

Wetted Parts according to a. m. material list are supplied as standard according to NACE MR0175/MR0103 and ISO 15156 (latest issue).

Pressure Test:

A shell test at 1.5 times the max. allowable (working) pressure and a seat leakage test are performed acc. to EN 12266-1 – P10, P11 and P12 respectively MSS-SP61 (and complies also with ASME B31.1 and B31.3) at every standard AS-Schneider Needle Valve / Manifold. 100% Pressure Tested!

Certification:

Certified Mill Test Report (CMTR) as Inspection certificate 3.1 acc. to EN 10 204 for valve body material and pressure test available on request.



Packing adjustment may be required during the service life of the valve.



Valves that have not been cycled for a period of time may have a higher initial actuation torque.

Optional Features

Fugitive Emission Application:

For Fugitive Emission Applications please contact the factory.

Oxygen Service:

AS-Schneider offers an option with Reinforced PTFE Packing cleaned and lubricated for Oxygen Service:

Pressure-Temperature Rating:

Max. 6,092 psi (420 bar) @ 140°F (60°C)

Max. 392°F (200°C) @ 1,305 psi (90 bar)

Not every Valve Type is available for Oxygen Service!

If you don't find your options in this catalogue, please contact the factory.

SDMS are manufactured to the following Codes and Specifications:

- ASME B31.1 Power Piping
- ASME B31.3 Process Piping
- ASME B16.34 Valves – Flanged, Threaded and Welding End
- API 598 Valve Inspection and Testing
- MSS SP-25 Standard Marking Systems for Valves, Fittings and Flange Unions
- MSS SP-61 Pressure Testing of Valves
- MSS SP-99 Instrument Valves
- MSS SP-105 Instrument Valves for Code Applications
- NACE MR0175 / ISO 15156 Petroleum and Natural Gas Industries – Materials for use in H₂S - Containing environments in oil and gas production
- IEC 61518 Standard Flange Connection Type B

Features and Benefits

Meets the challenge – Soft goods available to meet the toughest dirty gas applications. H₂S, CO₂, amines, corrosion inhibitors, methanol, glycol, etc.!

- 1. NEW STEM DESIGN
Reduced operating torque.
Minimized gap between stem and stem nut for additional operating thread protection.
- 2. COST SAVINGS
Extended seal and packing life.
- 3. REDUCES FREEZING ISSUES
Flow paths machined to self drain condensates and liquid accumulation.
- 4. PROTECTION AND CONVENIENCE
6 1/2 turns to full open & close isolation valves. Protects electronics from pressure spikes.
- 5. CATHODIC PROTECTION
Dielectric isolators protect expensive electronics.

- 6. COMFORTABLE EASY TURN
Ergonomic handle design.
 - 7. SAFETY
Ships assembled & pressure tested.
No seat and bonnet field assembly required.
- FINALLY**
Bug plug standard in 5 valve manifold vent port (not shown).

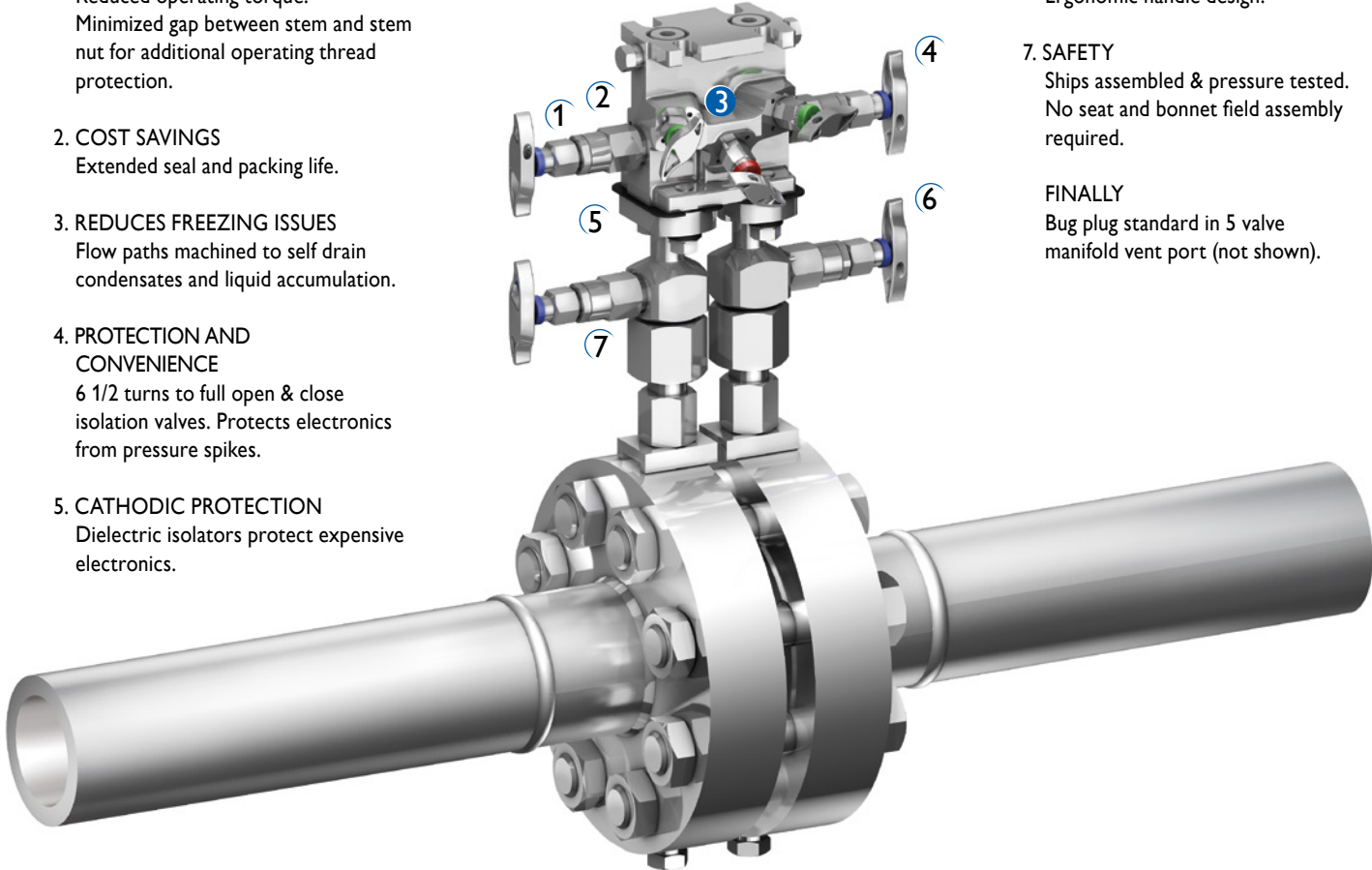

Pressure-Temperature Rating (Soft Seat)

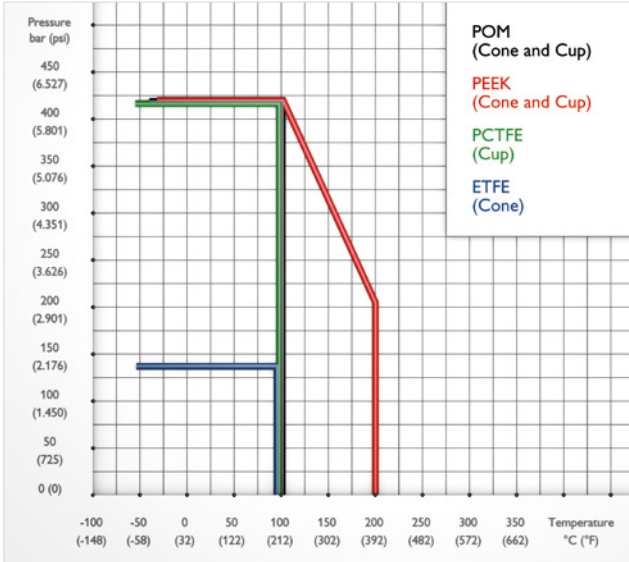

Stem Seal Material

Material	Temperature	
	Min.	Max.
FKM	-13°F (-25°C)	392°F (200°C)
FKM (RGD resistant)	-40°F (-40°C)	450°F (232°C)
FEPM	-4°F (-20°C)	392°F (200°C)
PTFE	-67°F (-55°C)	450°F (232°C)

Low Temperature Service down to -55°C (-67°F) – As standard for Valves with PTFE Packing and Soft Seats in ETFE resp. PCTFE only.

Temperature Limit for Body Material:
- Carbon Steel A105: -20°F (-29°C)
All other materials are limited by soft goods.

Isolate Valves – Head Units

Isolate Valves (Block Valves)

Bore Size 3/8" (9.5 mm) – Stem Seal: O-Ring
– Soft Seat: Cone Design

Features

- Rising Plug Valve Design
- Replaceable Valve Seat – ETFE, optional POM or PEEK
- Stem Seal – O-Ring in FKM (optional RGD resistant) or FEPM
- Non-rotating Needle
- External Stem Thread – Packing below stem threads. Stem threads are protected from process media (non-wetted).
- 6.5 turns to fully open or close the valve
- Heavy Duty Stem Threads
- Blow-out Proof Stem
- Back Seat – Metal to metal secondary stem seal
- Lock Pin – Eliminates unauthorized removal of the bonnet
- Color Coded Dust Cap for operating thread protection. Minimized gap between stem and stem nut for additional operating thread protection.
- Valve Seat in ETFE 2,000 psi (138 bar) rated – POM/PEEK 6,092 psi (420 bar) rated
- All non-wetted parts are 316 Stainless Steel

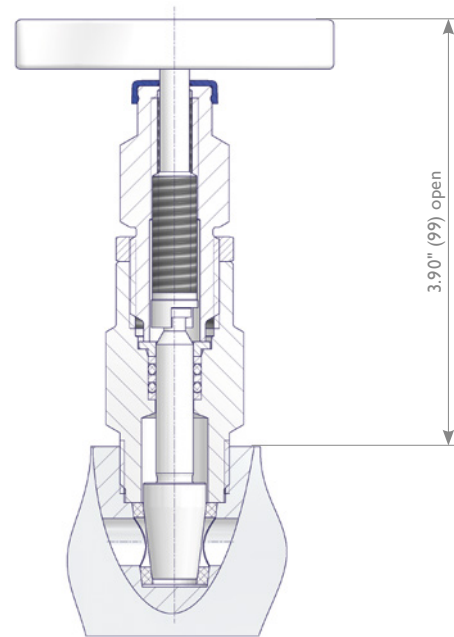

Isolate Valves (Block Valves)

Bore Size 3/8" (9.5 mm) – Stem Seal: PTFE Packing
– Soft Seat: Cone Design

Features

- Rising Plug Valve Design
- Replaceable Valve Seat – ETFE, optional POM or PEEK
- Stem Seal – PTFE Packing
- All other features as above

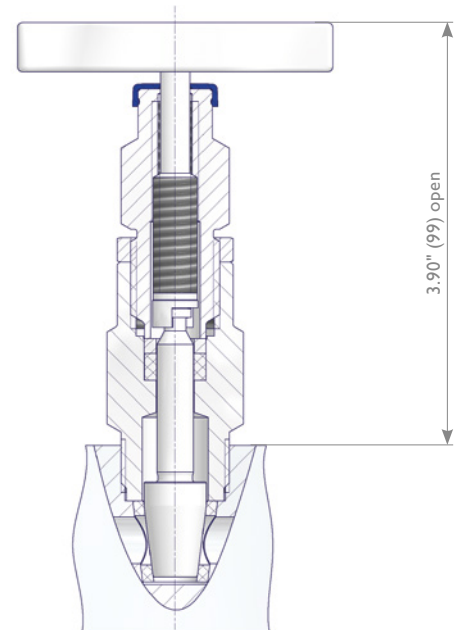

Components	Carbon Steel	Stainless Steel	Exotic Alloys	
	Material			
Body	A105	316 / 316L	Alloy 400	Alloy C-276
Bonnet	316 / 316L		Alloy 400	Alloy C-276
Seat	ETFE, POM or PEEK			
Needle	316 / 316L		Alloy 400	Alloy C-276
O-Ring	FKM or FEPM			
Packing	PTFE			
Valve Stem	316 / 316L			
Gland	316			
Stem Nut	316			
Lock Nut	316			
Set Screw	316			
T Handle	316			
Lock Pin	A4 (316)			

Wetted components listed in **bold**.

Equalize and Vent Valves – Head Units

Equalize and Vent Valves

- Bore Size 0.138" (3.5 mm)** – Stem Seal: O-Ring
 – Soft Seat: Cup Design

Features

- Replaceable Valve Seat - POM, optional PCTFE or PEEK
- Stem Seal - O-Rings in FKM (optional RGD resistant) or FEPM
- External Stem Thread - Packing below stem threads. Stem threads are protected from process media (non-wetted).
- 2.5 turns to fully open or close the valve
- Stem with Cold Rolled Threads
- Blow-out Proof Stem
- Back Seat - Metal to metal secondary stem seal
- Lock Pin - Eliminates unauthorized removal of the bonnet
- Color Coded Dust Cap for operating thread protection.
- Minimized gap between stem and stem nut for additional operating thread protection.
- Max. allowable (Working) Pressure (PS): 6,092 psi (420 bar)

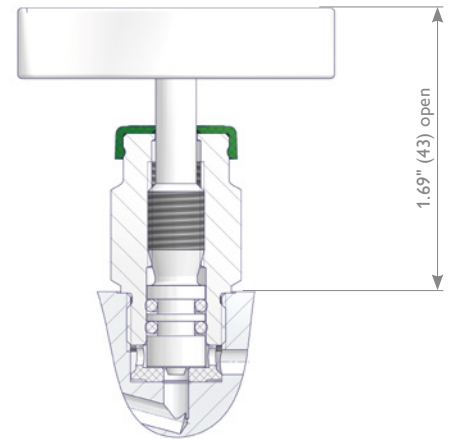

Equalize and Vent Valves

- Bore Size 0.138" (3.5 mm)** – Stem Seal: Packing
 – Soft Seat: Cup Design

Features

- Replaceable Valve Seat – POM, optional PCTFE or PEEK
- Stem Seal – PTFE Packing
- Non-rotating Needle
- External Stem Thread – Packing below stem threads. Stem threads are protected from process media (non-wetted).
- 4 turns to fully open or close the valve
- Stem with Cold Rolled Threads
- Blow-out Proof Stem
- Back Seat – Metal to metal secondary stem seal
- Lock Pin – Eliminates unauthorized removal of the bonnet
- Color Coded Dust Cap for operating thread protection
- Max. allowable (Working) Pressure (PS): 6,092 psi (420 bar)
- All non-wetted parts are 316 Stainless Steel

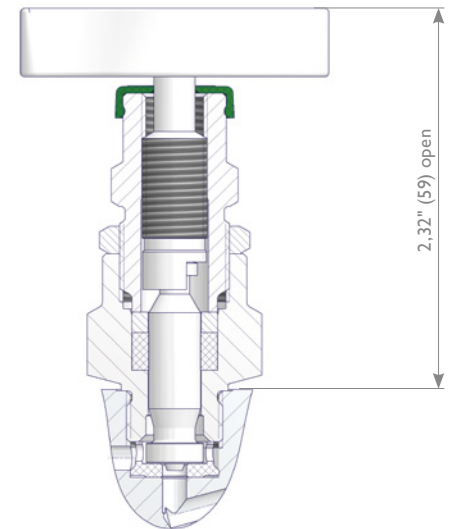

Equalize and Vent Valves - O-Ring Head Unit

Components	Carbon Steel	Stainless Steel	Exotic Alloys	
	Material			
Body	A105	316 / 316L	Alloy 400	Alloy C-276
Bonnet	316 / 316L		Alloy 400	Alloy C-276
Seat	POM, PCTFE or PEEK			
Valve Stem	316 / 316L		Alloy 400	Alloy C-276
O-Ring	FKM or FEPM			
Set Screw	316			
T Handle	316			
Lock Pin	A4			

Wetted components listed in **bold**.

Equalize and Vent Valves - Packing Head Unit

Components	Carbon Steel	Stainless Steel	Exotic Alloys	
	Material			
Body	A105	316 / 316L	Alloy 400	Alloy C-276
Bonnet	316 / 316L		Alloy 400	Alloy C-276
Seat	POM, PCTFE or PEEK			
Needle	316 / 316L		Alloy 400	Alloy C-276
Packing	PTFE			
Valve Stem	316 / 316L			
Gland	316			
Stem Nut	316			
Lock Nut	316			
Set Screw	316			
T Handle	316			
Lock Pin	A4			

Wetted components listed in **bold**.

Stabilized Connectors

Designing your Schneider DirectMount System

The first item required for SDMS is the Stabilized Connector. The Stabilized Connector provides the foundation for your SDMS.

Select the proper model for your installation considering:

- Clearance requirements
- Dielectric isolation
- Orifice tap centers – 2 1/8" (54 mm) to 2 1/4" (57 mm)
- Size and weight of the electronic measurement device
- Environmental site location

The connector's tensioning nut places the NPT threads in tension and transfers radial forces away from the NPT threads. The Short Type is designed to be installed without shoe, the Long Type and the Integral Valve Type are designed to be installed with shoe, providing a very solid and efficient connection.

The Integral Valve Type is provided with a **patented** swivel nut connection, enabling the easy positioning of the flange in any position through 360°. Therefore the Integral Valve Type does not require field assembly providing a simple pretested safe assembly to the orifice fitting.

The elongated bolt holes accommodate 2 1/8" (54 mm) to 2 1/4" (57 mm) centers.

Dielectric Isolation Kits are available (see page 19).

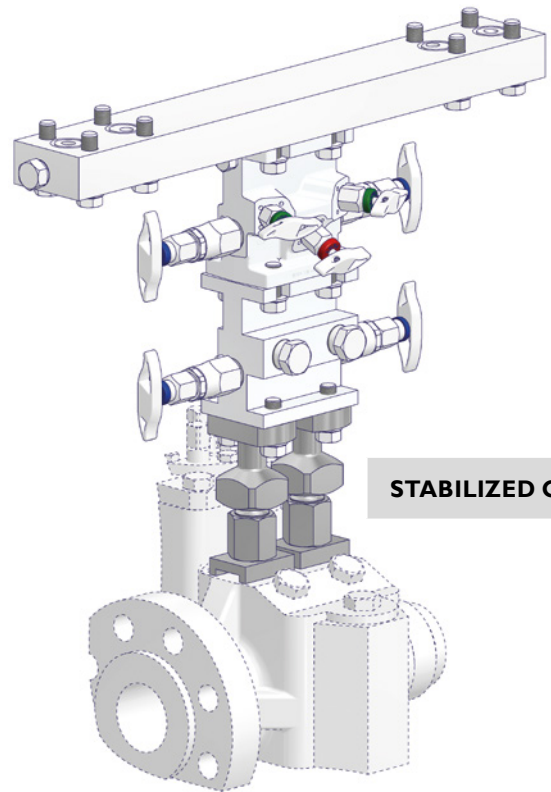

Short Type Stabilized Connector

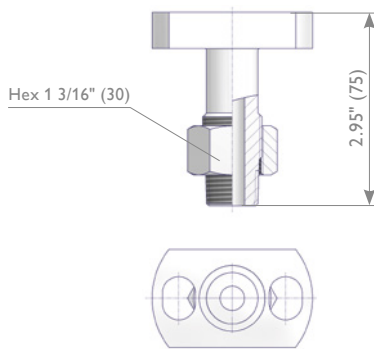

Long Type Stabilized Connector

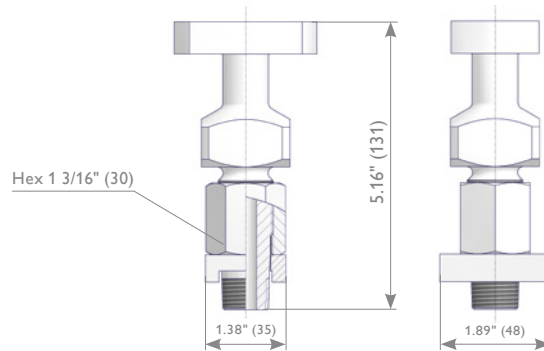

Integral Valve Type Stabilized Connector

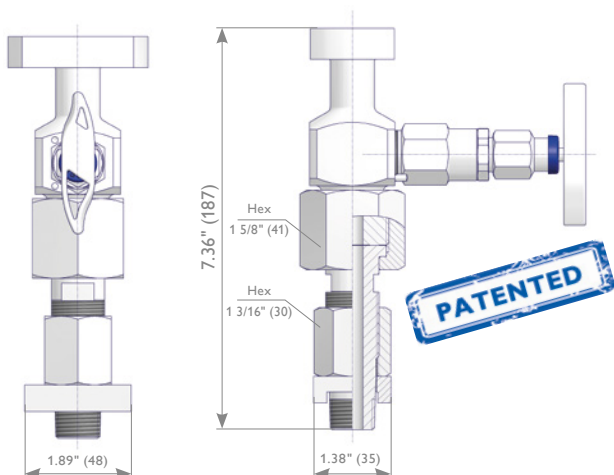

Dielectric Isolation Kit

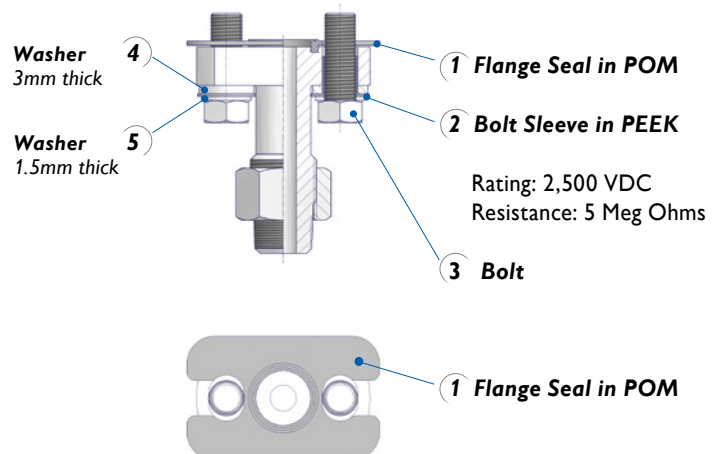

Stabilized Connectors and Spacers

Ordering Information - Stabilized Connectors

	1	2	3	4	5	6	7	8	9	10	11	12	13	14	15	16
	S	T	C	-	L	S	0	0	-							
STC Stabilized Connectors (always supplied as pair)																
Dash																
Stabilized Connector Design																
S	Short			V	Integral Valve											
L	Long															
Material																
C	Carbon Steel A105			M	Alloy 400 UNS N04400											
S	1.4404 / 1.4401 / 316 / 316L			H	Alloy C-276 UNS N10276											
Stem Seal / Packing																
0	Stabilized Connectors without Isolation Valve			P	O-Ring FEPM											
K	O-Ring FKM			A	PTFE Packing											
J	O-Ring FKM (RGD resistant)															
Seat Material																
0	Stabilized Connectors without Isolation Valve			D	POM – 6,092 psi (420 bar) rated											
E	ETFE – 2,000 psi (138 bar) rated			P	PEEK – 6,092 psi (420 bar) rated											
Dash																
Options – Specify in alphabetical order (digits first then letters)																
B	Cleaned for Oxygen Service															
D	Dielectric Isolation – Only to be ordered with Accessory Kit Option Code 1 or 2															
M	Wetted Parts with Certified Mill Test Report (CMTR) as 3.1 certificate acc. to EN 10204															
W	Without Stabilizer Shoe – Vertical/Light Duty Installations delivered without Shoe															
1	Hex Head Bolts 7/16-20 UNF x 1 1/4" lg. in CS and Washers in SS, Seal Ring in PTFE															
2	Hex Head Bolts 7/16-20 UNF x 1 1/4" lg. and Washers in SS*, Seal Ring in PTFE															

* Bolt Material SS = 316 Stainless Steel I ASTM F593 GP2 CW

Wetted Parts according to above mentioned material list are supplied according to NACE MR0175/MR0103 and ISO 15156 (latest issue).

Ordering Information - Spacers

	1	2	3	4	5	6	7	8	9	10	11	12	13	14	15	16
	H	0	S	-	S	0	0	-	2							
Spacers																
H0	Spacer – Flange x Flange															
Spacer Design																
S	Straight Type															
Dash																
Body Material																
C	Carbon Steel A105			M	Alloy 400 UNS N04400											
S	1.4404 / 1.4401 / 316 / 316L			H	Alloy C-276 UNS N10276											
Zero																
Dash																
Options – Specify in alphabetical order (digits first then letters)																
B	Cleaned for Oxygen Service															
S	Universal Flange Interface (MSS SP-99 / IEC 61518) - on inlet															
Accessory Kits – For Manifold to Transmitter mounting																
1	Hex Head Bolts 7/16-20 UNF x 1" lg. in CS and Washers in SS, PTFE Seal Ring															
2	Hex Head Bolts 7/16-20 UNF x 1" lg. and Washers in SS*, PTFE Seal Ring															
7	FKM O-Rings for Flange Seal – Only to be ordered with Accessory Kit Option Code 1 or 2 For example Spacer with Bolts, Washers and Seal Rings acc. to Option Code 2, but instead of PTFE Seal Ring with FKM Seal Ring add Option Code 27															

* Bolt Material SS = 316 Stainless Steel I ASTM F593 GP2 CW

Wetted Parts according to above mentioned material list are supplied according to NACE MR0175/MR0103 and ISO 15156 (latest issue).

Spacers and 2 Valve Manifolds

Designing your Schneider DirectMount System

After selecting your stabilized connector consider if an optional Spacer or 2 Valve Manifold is required:

- Consider any clearance requirements, provide additional clearance between the orifice meter and your measurement device.
- 2 Valve Manifolds are recommended to eliminate the need to blow down your meter tube when periodic maintenance is required.

Ordering Information Spacer (Straight Adapter) see page 9.

Ordering Information 2 Valve Manifold see page 13.

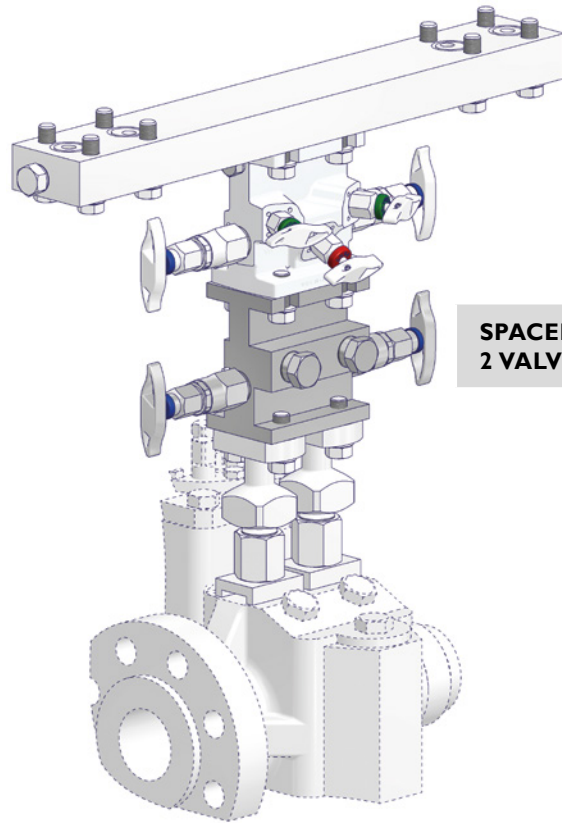

**SPACERS AND
2 VALVE MANIFOLDS**

Spacer (Straight Adapter)

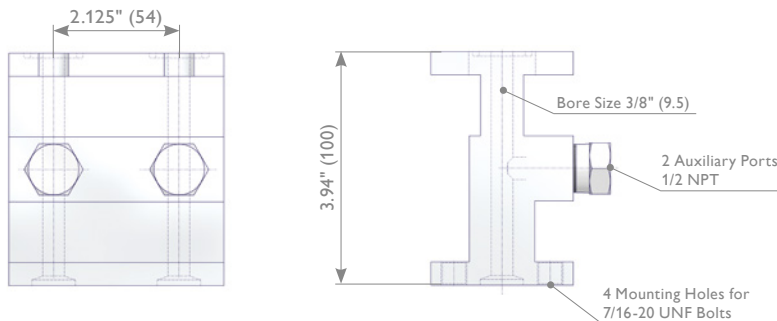

2 Valve Manifold

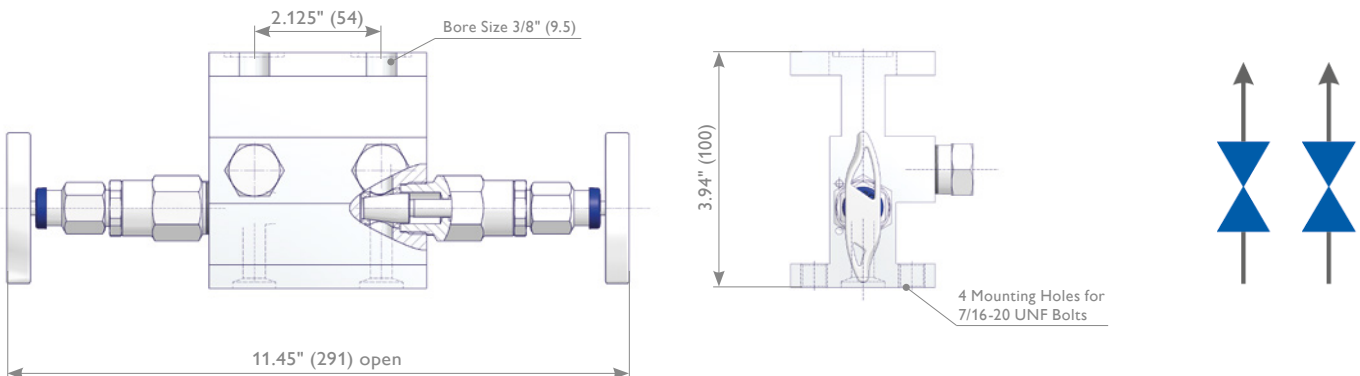

5 Valve Manifolds

The next step after selecting the stabilized connector and the optional Spacer / 2 Valve Manifold is to select the proper 5 Valve Manifold.

Vertical Installations – Select the Straight Type 5 Valve Manifold.

Horizontal Installations – Select the Angle Type 5 Valve Manifold (orients electronics of the transmitter in vertical position) or the Straight Type 5 Valve Manifold.

The 5 Valve Manifold is used in most custody transfer applications. However if you don't require a 5 Valve Manifold AS-Schneider is also supplying a 3 Valve Manifold. For more details please contact the factory.

When mounting the 5 Valve Manifold to ΔP Transmitter, Smart Multivariable or Flow Computer you must consider the mounting bolt lengths.

5 Valve Manifold Vent Port – The 1/4 NPT female Vent Port is supplied with a fitted Bug Plug as standard.

Roddable - Both Straight and Angle Type 5 Valve Manifolds.

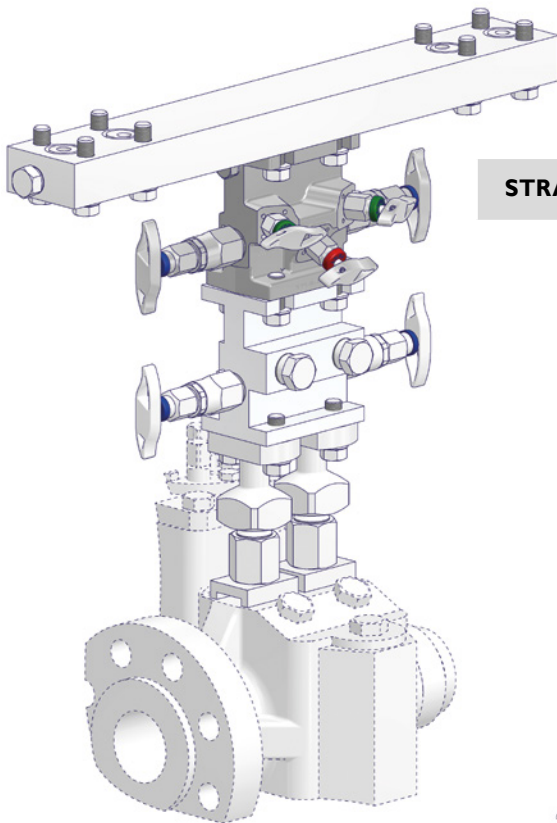

STRAIGHT TYPE 5 VALVE MANIFOLD

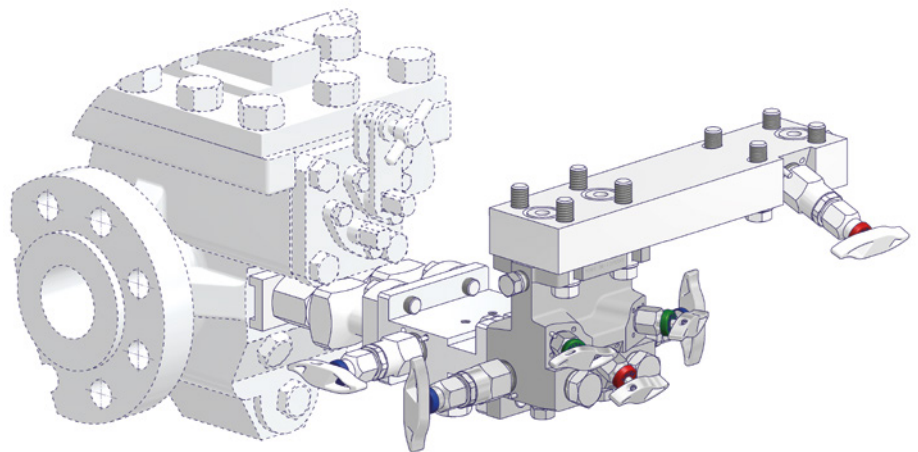

ANGLE TYPE 5 VALVE MANIFOLD

5 Valve Manifolds

Flow Pattern of Straight Type 5 Valve Manifold

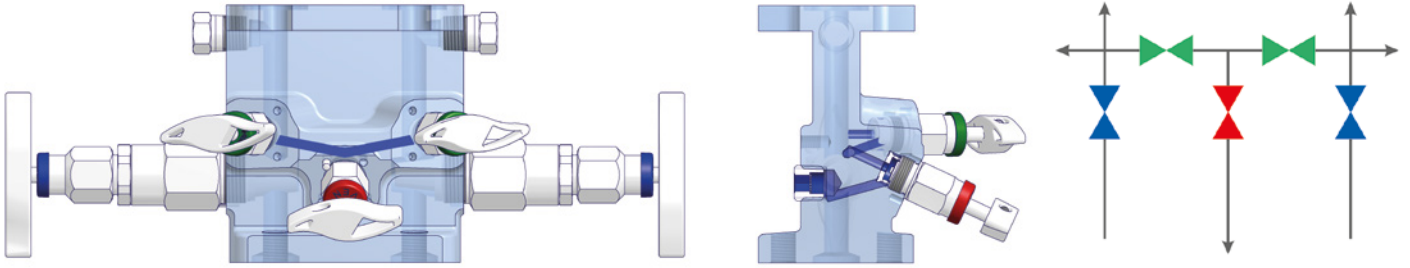

Flow Pattern of Angle Type 5 Valve Manifold

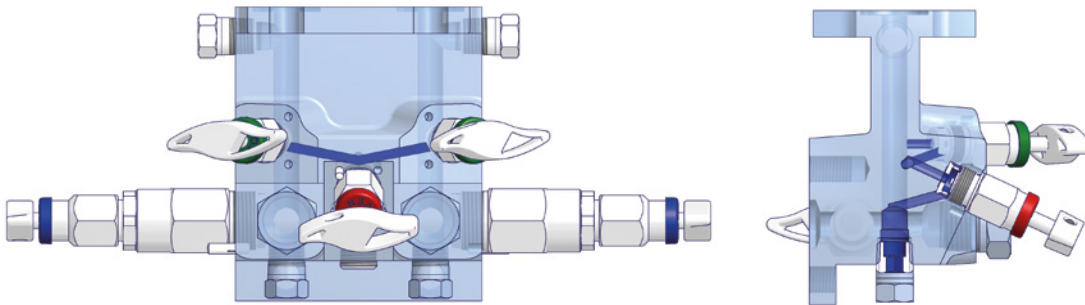

REDUCES FREEZING ISSUES:
Flow paths machined to self drain condensates and liquid accumulation.

Straight Type 5 Valve Manifold

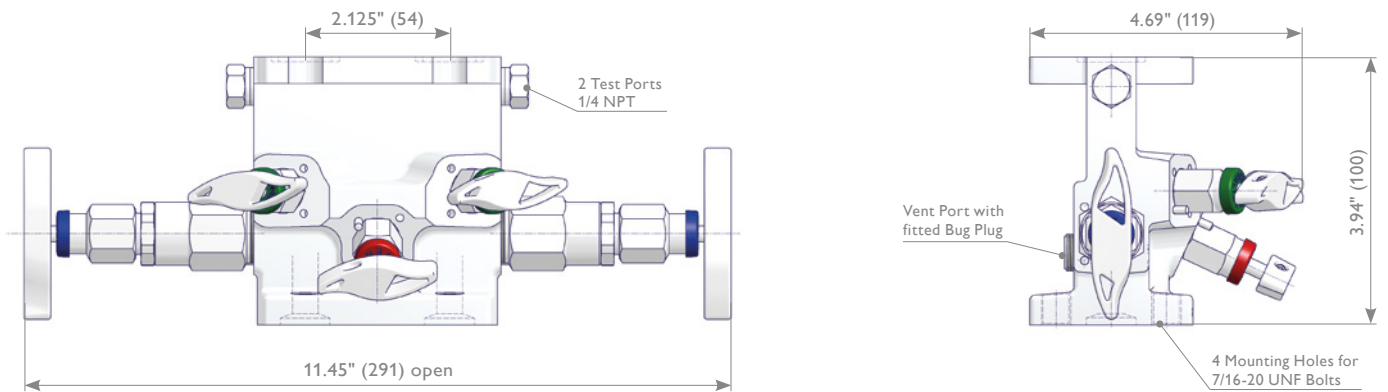

Angle Type 5 Valve Manifold

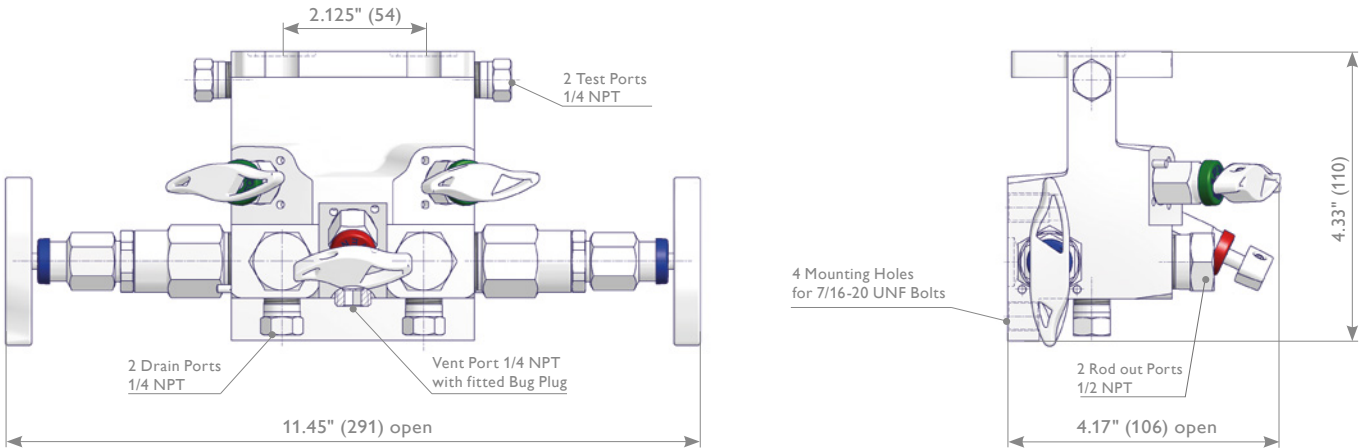

Ordering Information

	1	2	3	4	5	6	7	8	9	10	11	12	13	14	15	16
	H	5	S	-	S	K	A	-	2	D						
Manifolds																
H	H-Style Manifolds – Flange x Flange															
Quantity Bonnets																
2	2 Valve Manifold															
5	5 Valve Manifold															
Manifold Design																
S	Straight Type, 3/8" (9.5 mm) Bore Size on Isolate Valves															
L	Angle Type, 3/8" (9.5 mm) Bore Size on Isolate Valves															
Dash																
Body Material																
C	Carbon Steel A105				M	Alloy 400 UNS N04400										
S	1.4404 / 1.4401 / 316 / 316L				H	Alloy C-276 UNS N10276										
Stem Seal / Packing																
K	O-Ring FKM				P	O-Ring FEPM										
J	O-Ring FKM (RGD resistant)				A	PTFE Packing										
Seat Material – Isolate Valves x Equalize/Vent Valves																
A	ETFE x POM – 2,000 psi (138 bar) rated				D	POM x PCTFE – 6,092 psi (420 bar) rated										
B	POM x POM – 6,092 psi (420 bar) rated				P	PEEK x PEEK – 6,092 psi (420 bar) rated										
C	ETFE x PCTFE – 2,000 psi (138 bar) rated															
Dash																
Options – Specify in alphabetical order (digits first then letters)																
B	Cleaned and Lubricated for Oxygen Service															
D	Dielectric Isolation – Only to be ordered with Accessory Kit Option Code 1 to 6															
M	Wetted Parts with Certified Mill Test Report (CMTR) as 3.1 certificate acc. to EN 10204															
S	Universal Flange Interface (MSS SP-99 / IEC 61518) - for inlet															
Accessory Kits – For Manifold to Transmitter mounting																
1	Hex Head Bolts 7/16-20 UNF x 1" lg. in CS, Washers in SS, PTFE Seal Ring –				To mount Transmitters / Flow Computers with Traditional Flange and ΔP to ΔP Adapters.											
2	Hex Head Bolts 7/16-20 UNF x 1" lg. and Washers in SS*, PTFE Seal Ring –				To mount Transmitters / Flow Computers with Traditional Flange and ΔP to ΔP Adapters.											
3	Hex Head Bolts 7/16-20 UNF x 2 1/4" lg. in CS, Washers in SS, PTFE Seal Ring –				1. To mount Transmitters / Flow Computers with Rosemount Coplanar™ Flange (with Dielectric Isolation: Option Code 3D). 2. To mount ΔP to Static Adapters and Transmitters / Flow Computers with Traditional Flange. For this Application the Bolt Length for Manifolds with or without Dielectric Isolation are identical. (With Dielectric Isolation: Option Code DV) <i>For 5 Valve Manifolds only. 2 Valve Manifolds supplied with 1" lg. Bolts.</i>											
4	Hex Head Bolts 7/16-20 UNF x 2 1/4" lg. and Washers in SS*, PTFE Seal Ring –				1. To mount Transmitters / Flow Computers with Rosemount Coplanar™ Flange (with Dielectric Isolation: Option Code 4D). 2. To mount ΔP to Static Adapters and Transmitters / Flow Computers with Traditional Flange. For this Application the Bolt Length for Manifolds with or without Dielectric Isolation are identical. (With Dielectric Isolation: Option Code DY). <i>For 5 Valve Manifolds only. 2 Valve Manifolds supplied with 1" lg. Bolts.</i>											
5	Hex Head Bolts 7/16-20 UNF x 3 1/2" lg. in CS, Washers in SS, PTFE Seal Ring –				To mount ΔP to Static Adapters and Transmitters / Flow Computers with Rosemount Coplanar™ Flange. <i>For 5 Valve Manifolds only. 2 Valve Manifolds supplied with 1" lg. Bolts.</i>											
6	Hex Head Bolts 7/16-20 UNF x 3 1/2" lg. and Washers in SS*, PTFE Seal Ring –				To mount ΔP to Static Adapters and Transmitters / Flow Computers with Rosemount Coplanar™ Flange. <i>For 5 Valve Manifolds only. 2 Valve Manifolds supplied with 1" lg. Bolts.</i>											
7	FKM O-Rings for Flange Seal – Only to be ordered with Accessory Kit Option Code 1 to 6. For Example Manifold with Bolts, Washers and Seal Rings acc. to Option Code 2, but instead of PTFE Seal Ring with FKM Seal Ring add Option Code 27.															
NOTE: Manifolds with Dielectric Isolation supplied with additional 1/4" to bolt length.																

* Bolt Material SS = 316 Stainless Steel | ASTM F593 GP2 CW

Wetted Parts according to above mentioned material list are supplied according to NACE MR0175/MR0103 and ISO 15156 (latest issue).

Universal Flange Interface (MSS SP-99 / IEC 61518)

Designing your Schneider DirectMount System

The Standard Flange Interface of the AS-Schneider SDMS-System is according to DIN EN 61518 / IEC 61518, TypeB. Using this standard makes sure that the dimension of the flange and gaskets, the bolt materials, marking and also the assembly are state of the art.

There are also installations which use the flange interface described in the standard MSS SP-99 and MSS-SP105. These standards just describe the geometry of the flange including the groove for the gasket, but gives no information on the gasket itself, nor on the bolting material or assembly.

AS-Schneider offers a special accessory kit including gaskets, bolts and washers for mounting a AS-Schneider Manifold to a Stabilized Connector with a MSS SP-99 flange.

This Accessory Kit can be used for the following products:

- H0S - Straight Spacer
- H2S - Straight 2 Valve Manifold
- H2L - Angle type 2 Valve Manifold
- H5S - Straight 5 Valve Manifold
- H5L - Angle type 5 Valve Manifold

Important Note:

When using this accessory kit, the AS-Schneider product must come with the Option Code S "Universal Flange Interface (MSS SP-99 / IEC 61518) - for inlet"

Accessory Kit with:

- 4x Hex Cap Screws 7/16-20 UNF – 1 1/4" length (for Stabilizers with flange thickness of 14mm)
- 4x Washer
- 2x PTFE Seal Rings (colored blue)

Ordering Information

Bolting Material	Part Number
Carbon Steel ASTM A449-Type 1	AKS-HT4C-PMF32
316 Stainless Steel ASTM A193 B/M Cl.2	AKS-HT4S-PMF32
316 Stainless Steel ASTM F593 GP2 CW	AKS-HT4F-PMF32

Adapters

When mounting both ΔP and Static Transmitter a SDMS Adapter is required. ΔP to ΔP Adapter is also available for Dual Custody and Bi-Directional Installations.

Bolt Selection for these Adapters is located on page 15.

ΔP to Static Adapters are full 3/8" Orifice (ΔP and Static Side) to reduce or eliminate freezing issues.

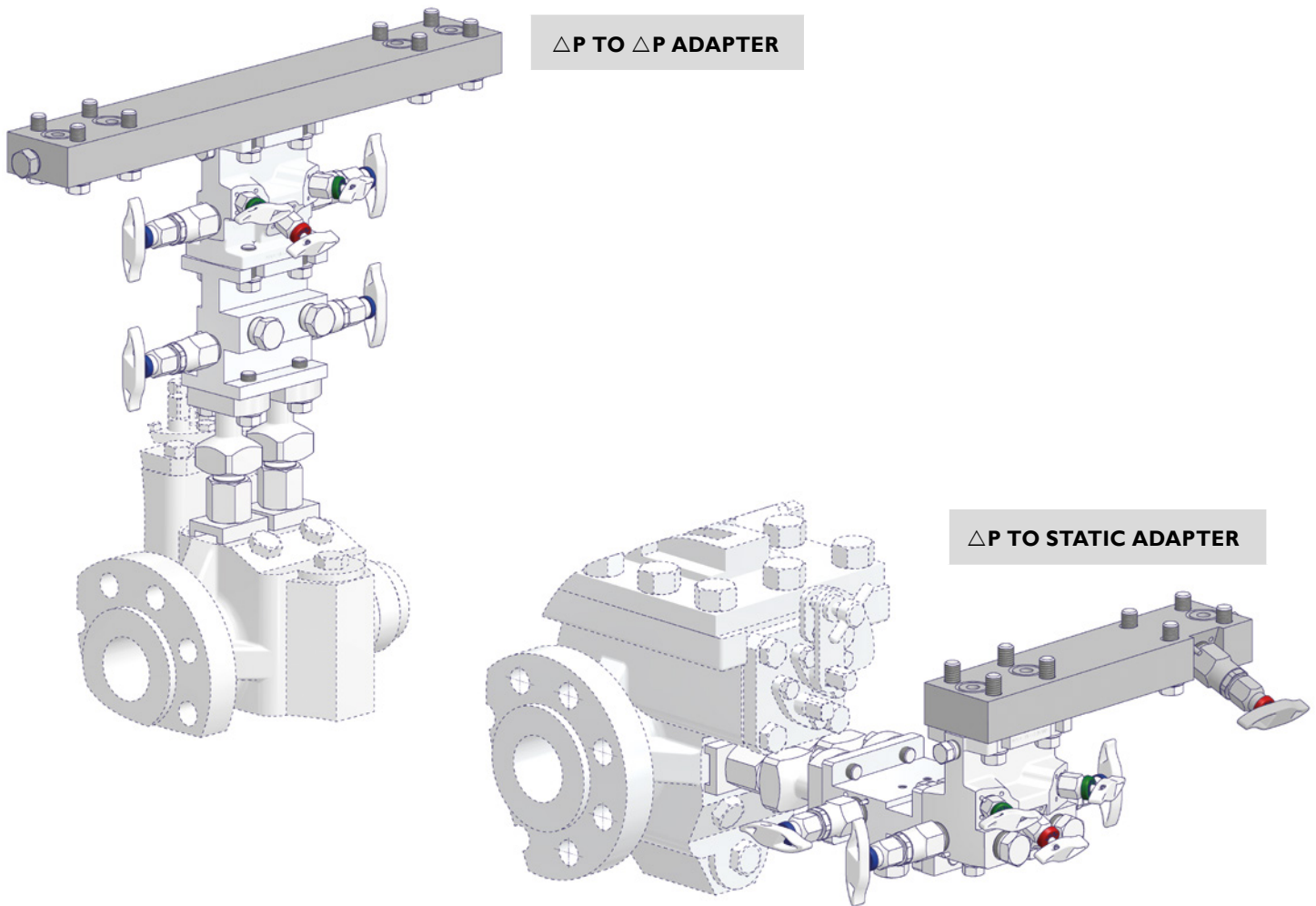

ΔP to ΔP Adapter – Bore Size 3/8" (9.5 mm)

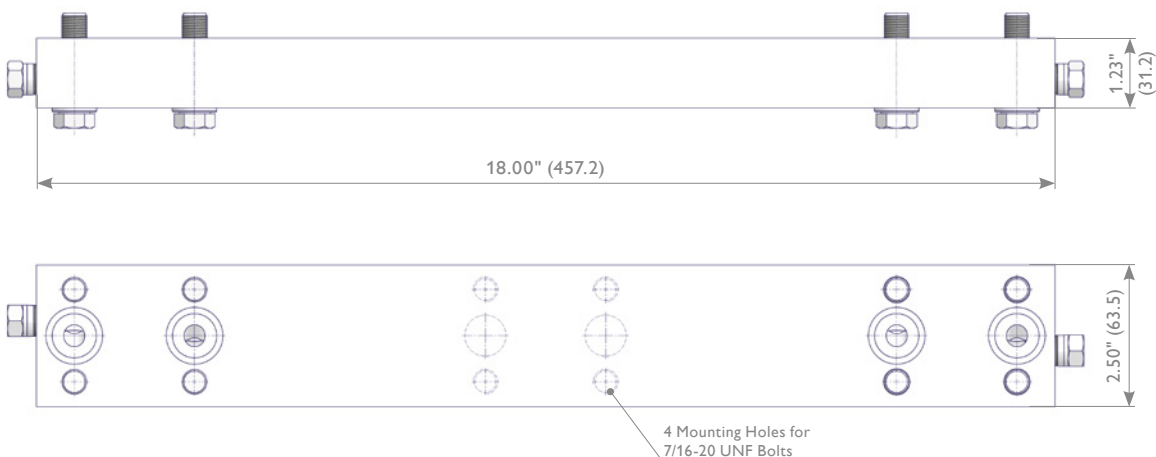

Adapters

ΔP to Static Adapter – Bore Size 3/8" (9.5 mm)

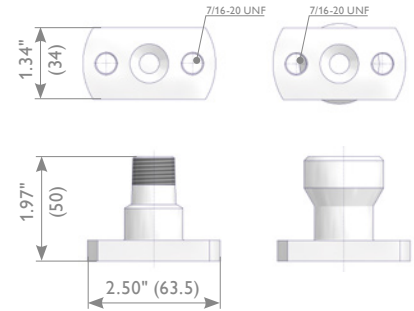
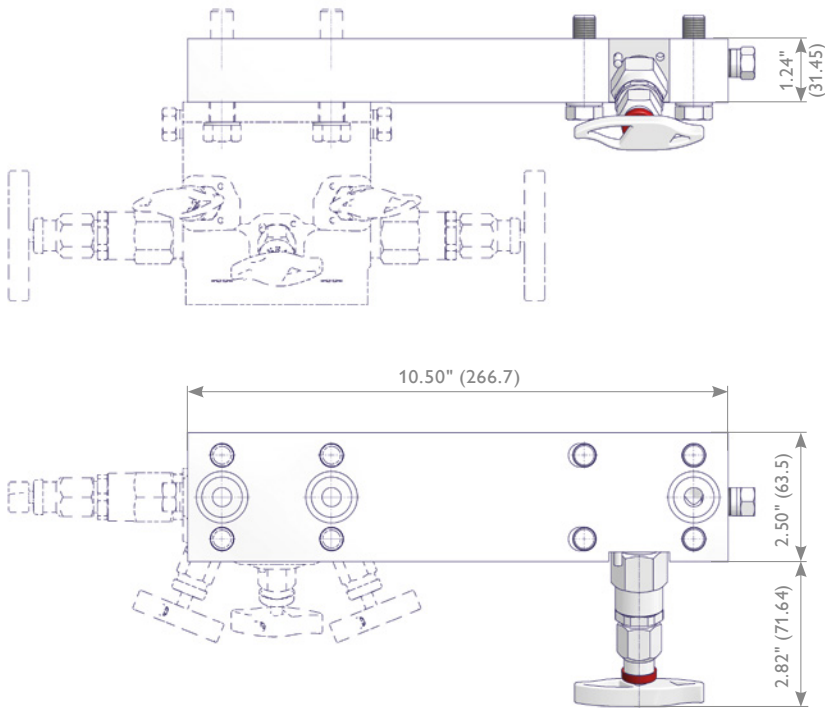

NPT Static Adapters

NPT Static Adapter	Part Number	
	Carbon Steel	Stainless Steel
1/2 NPT Female	AKA-FC	AKA-FS
1/2 NPT Male	AKA-MC	AKA-MS

To be ordered separately.

Ordering Information

	1	2	3	4	5	6	7	8	9	10	11	12	13	14	15	16
	A	K	A	-	S	S	K	B	-	2						
AKA Adapters																
Dash																
Adapters Design																
D	ΔP to ΔP Adapter → No Vent Valve															
S	ΔP to Static Adapter → 1 Vent Valve - Bore Size 3/8" (9.5 mm)															
Body Material																
C	Carbon Steel A105			M	Alloy 400 UNS N04400											
S	1.4404 / 1.4401 / 316 / 316L			H	Alloy C-276 UNS N10276											
Stem Seal / Packing																
0	Adapter without Vent Valve			P	O-Ring FEPM											
K	O-Ring FKM			A	PTFE Packing											
J	O-Ring FKM (RGD resistant)															
Seat Material – Vent Valve																
0	Adapter without Vent Valve			D	POM											
E	ETFE			P	PEEK											
Dash																
Options – Specify in alphabetical order (digits first then letters)																
Accessory Kits – To mount the Transmitters to the Adapters (ΔP to Static Adapter – Static Transmitter Side only)																
1	Hex Head Bolts 7/16-20 UNF x 1 3/4" lg. in CS and PTFE Seal Ring – To mount Traditional Flange Transmitters respectively NPT Static Adapters.															
2	Hex Head Bolts 7/16-20 UNF x 1 3/4" lg. in SS* and PTFE Seal Ring – To mount Traditional Flange Transmitters respectively NPT Static Adapters.															
3	Hex Head Bolts 7/16-20 UNF x 3 1/4" lg. in CS and PTFE Seal Ring – To mount Rosemount 2051/3051 Coplanar™ Flange Transmitters.															
4	Hex Head Bolts 7/16-20 UNF x 3 1/4" lg. in SS* and PTFE Seal Ring – To mount Rosemount 2051/3051 Coplanar™ Flange Transmitters.															
5	No Bolts (but supplied with Seal Rings) – Just 5 means Seal Rings PTFE, Seal Rings in FKM add Option Code 57.															
7	FKM O-Rings for Flange Seal – Only to be ordered with Accessory Kit Option Code 1 to 5. For Example Adapters with Bolts and Seal Rings acc. to Option Code 2, but instead of PTFE Seal Ring with FKM Seal Ring add Option Code 27.															
NOTE: ΔP to Static Adapter is supplied with 4 Bolts and 3 Seal Rings (1 for Static Transmitter, 2 for ΔP Transmitter). ΔP to ΔP Adapter is supplied with 8 Bolts and 4 Seal Rings.																

* Bolt Material SS = 316 Stainless Steel I ASTM F593 GP2 CW

Wetted Parts according to above mentioned material list are supplied according to NACE MR0175/MR0103 and ISO 15156 (latest issue).

Horizontal Installation – Exploded View

1. ORIFICE FITTING
2. STABILIZED CONNECTORS WITH INTEGRAL VALVE
3. DIELECTRIC ISOLATION
To be ordered with Stabilized Connector
4. ANGLE TYPE 5 VALVE MANIFOLD
c/w Accessory Kits to mount the Transmitters, Flow Computers or Adapters
5. ΔP TO STATIC ADAPTER (OPTIONAL)
c/w Accessory Kit for Static Transmitter Side
6. NPT STATIC ADAPTER

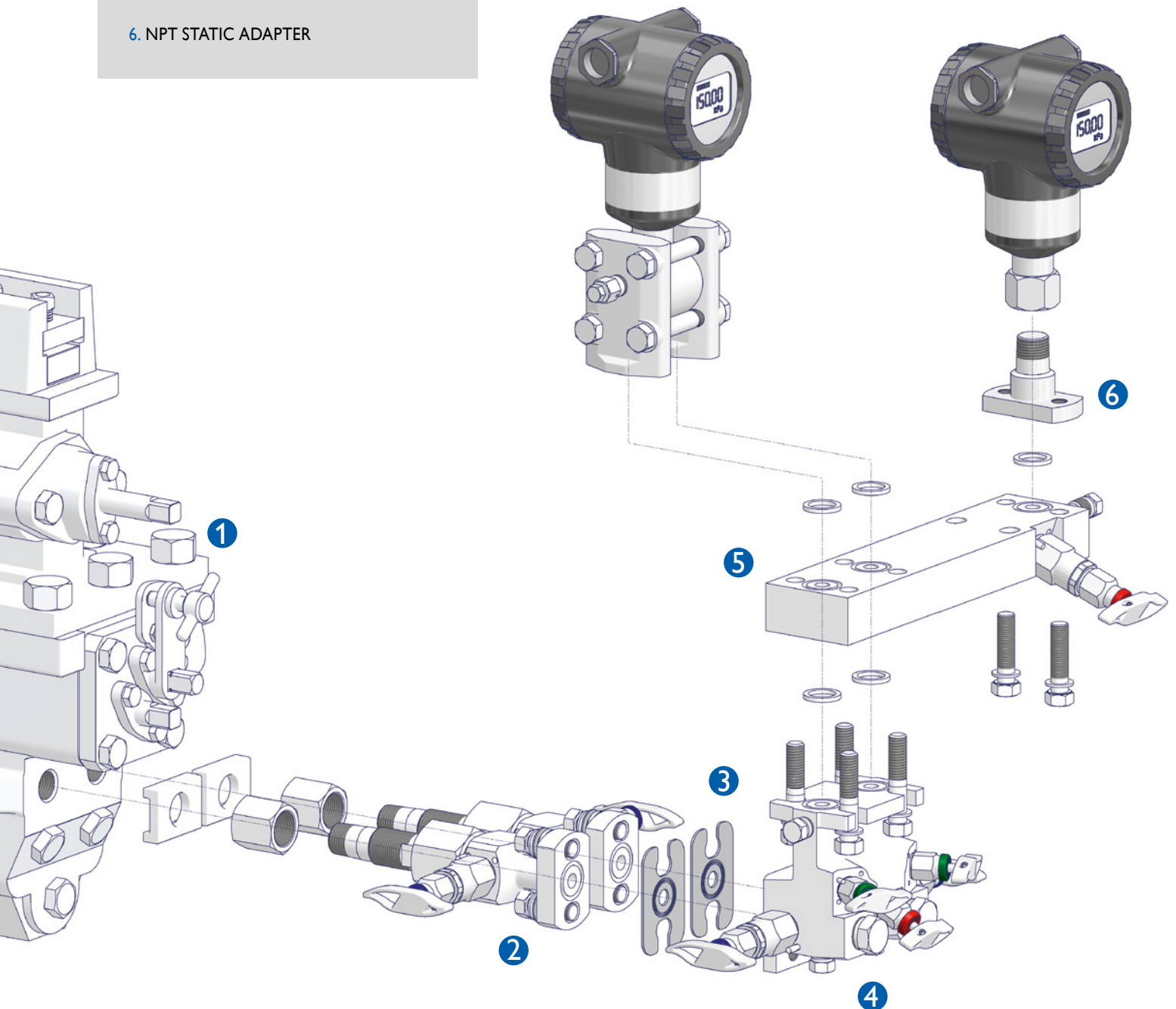

Vertical Installation

Vertical Installation – Exploded View

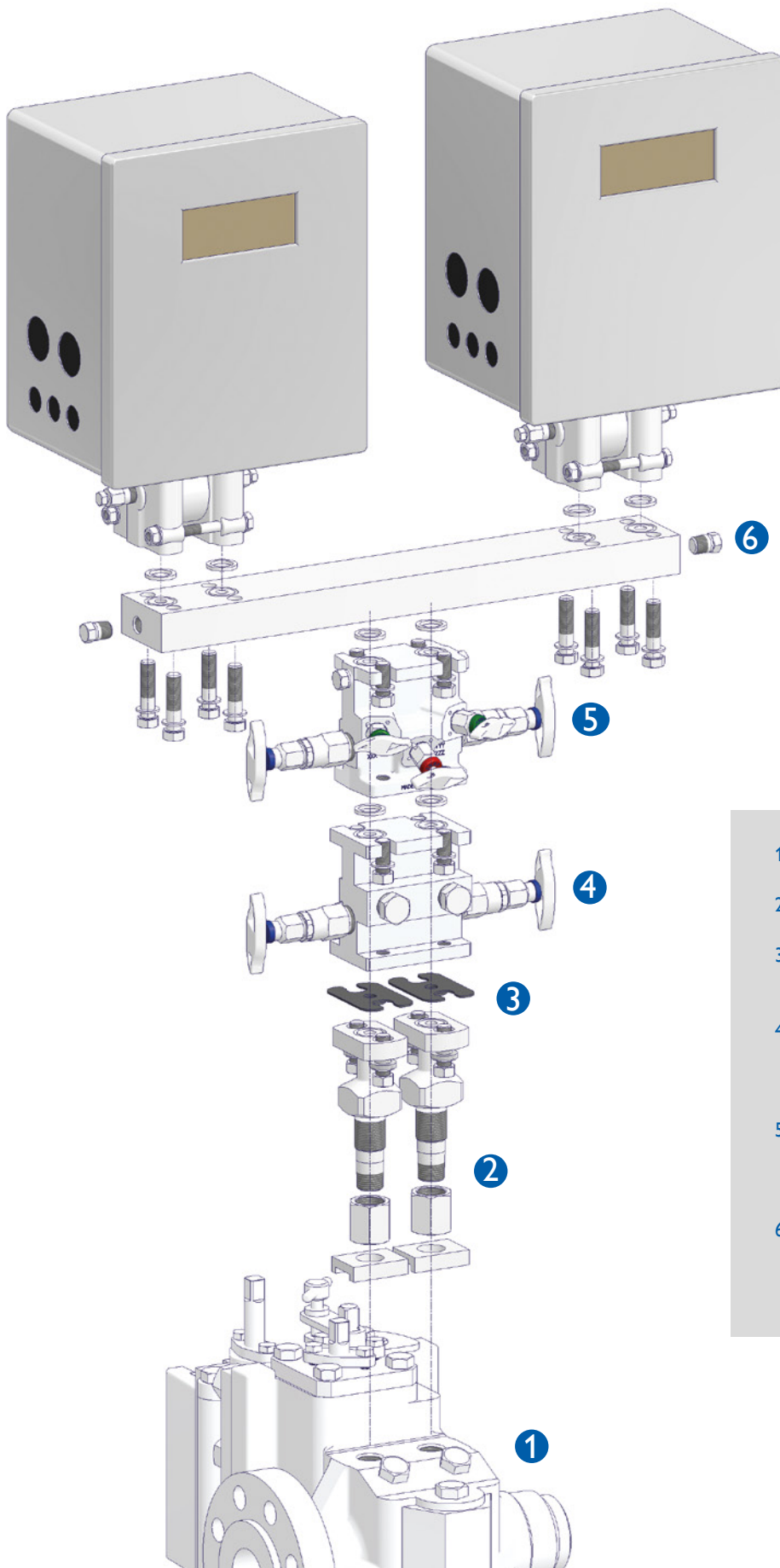

1. ORIFICE FITTING
2. STABILIZED CONNECTORS
3. DIELECTRIC ISOLATION
To be ordered with stabilized connector
4. SPACER OR 2 VALVE MANIFOLD (OPTIONAL)
c/w Accessory Kit
5. STRAIGHT TYPE 5 VALVE MANIFOLD
c/w Accessory Kits to mount the transmitters, flow computers or adapters
6. ΔP TO ΔP ADAPTER (OPTIONAL)
c/w Accessory Kits to mount the transmitters/flow computers

Manifolds for Ultrasonic Flow Meter Applications

Horizontal Installation of Flanged Type Block & Bleed Manifolds

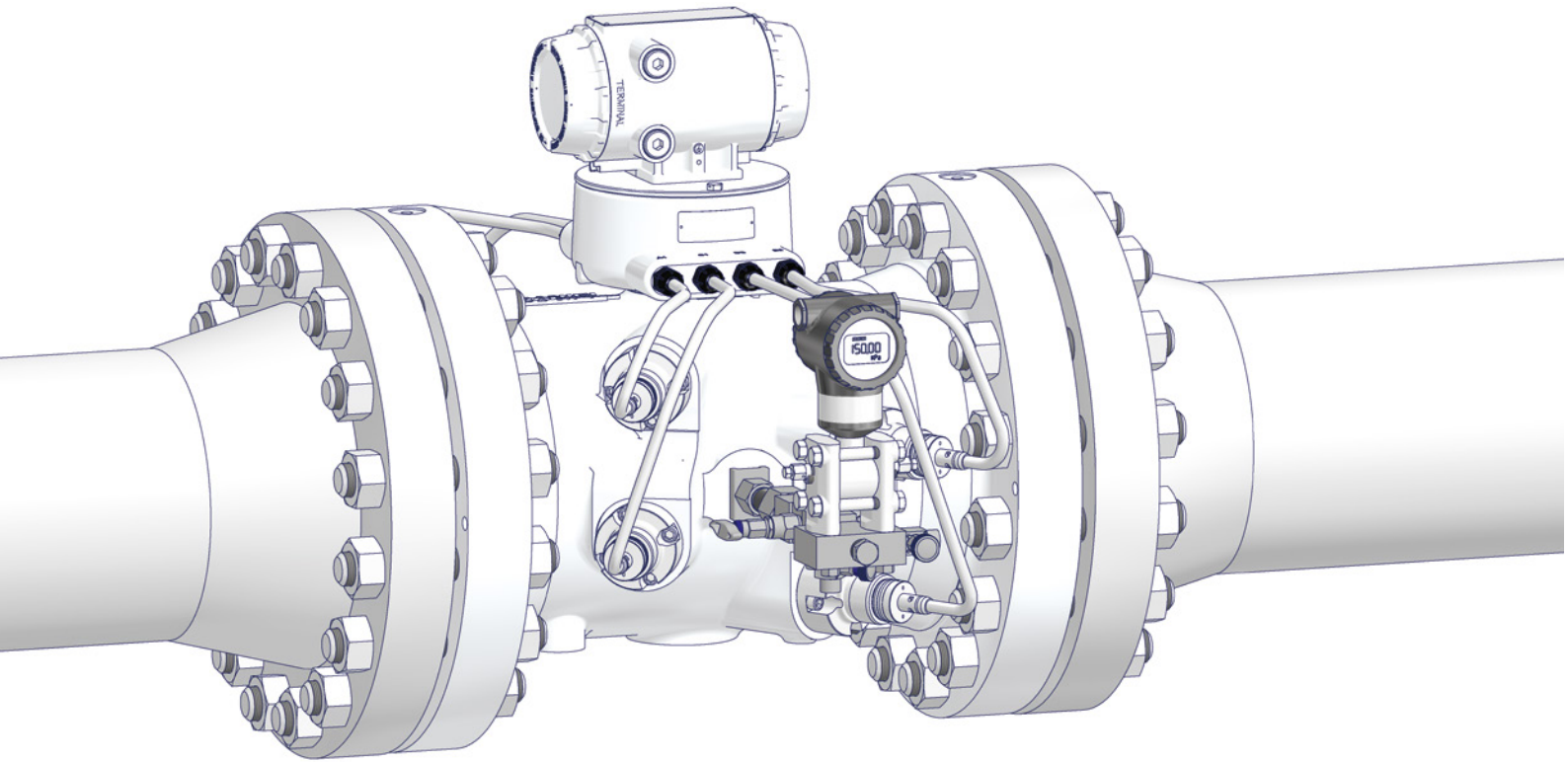

For detailed information see Catalogue 'AS-4302 I
Soft Seated Needle Valves and Manifolds – Page 24-26.

Horizontal Installation of Threaded Type Block & Bleed Manifolds

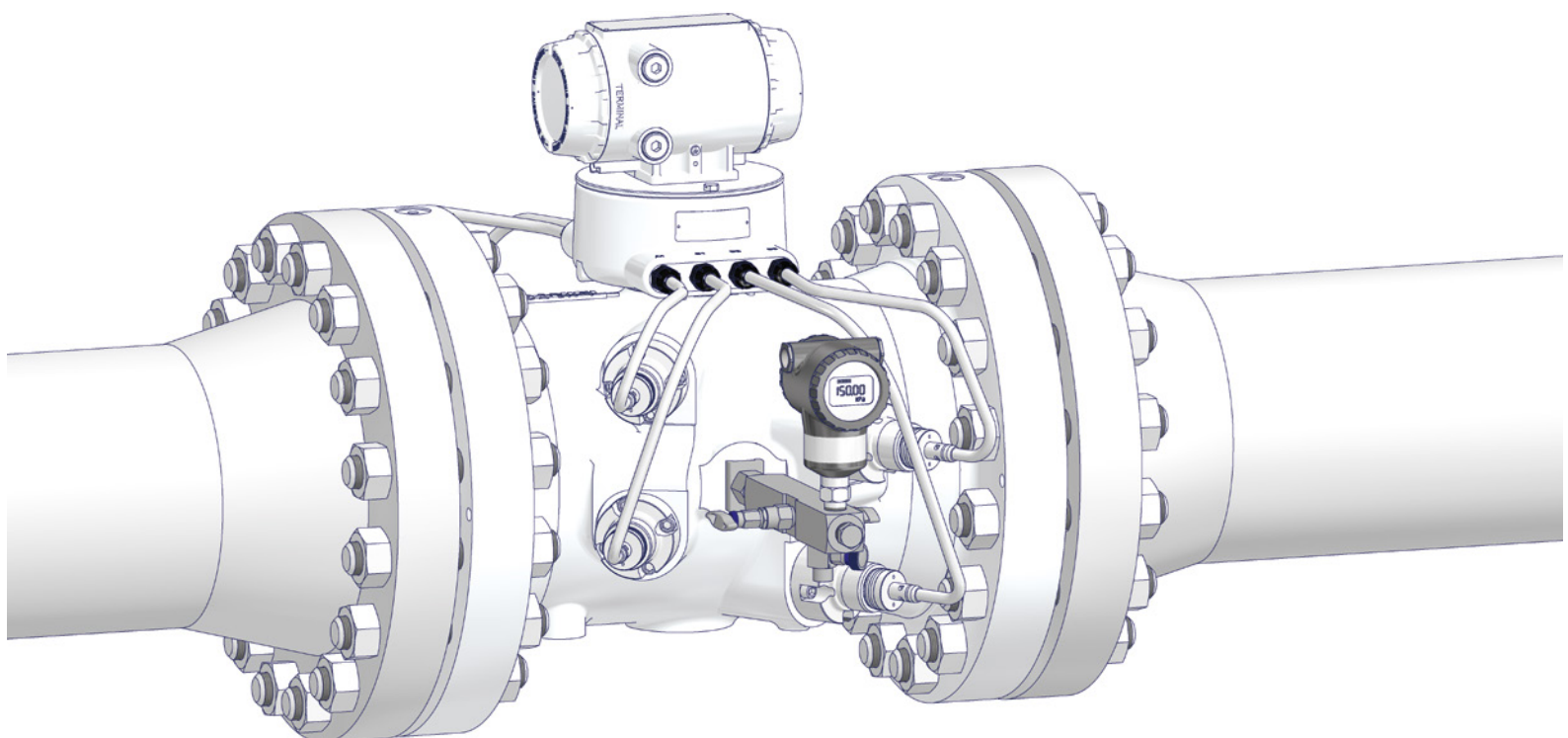

Spare Parts

Dielectric Isolation Kits

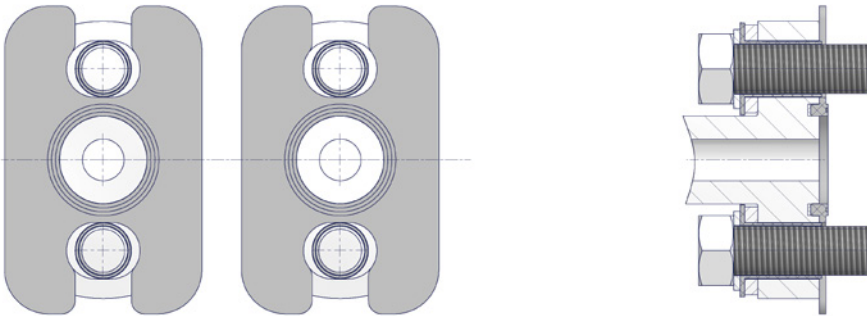

AS-Schneider is providing the following Dielectric Isolation Kits (always supplied as pair: 2 Dielectric Flange Seals, 4 Bolts, 4 Washers 1.5mm thick, 4 Washers 3mm thick and 4 Bolt Sleeves):

To mount a Stabilized Connector to a Spacer/Manifold:	Part Number
Dielectric Kit w/CS Bolts (1 1/2" lg.) and 316 SS Washers	DEK-01C
Dielectric Kit w/316 SS Bolts (1 1/2" lg.) and 316 SS Washers	DEK-01F

To mount a 5 Valve Manifold to a:	Part Number
Transmitter/Flow Computer with Traditional Flange	
Dielectric Kit w/CS Bolts (1 1/4" lg.) and 316 SS Washers	DEK-02C
Dielectric Kit w/316 SS Bolts (1 1/4" lg.) and 316 SS Washers	DEK-02F
Transmitter/Flow Computer with Rosemount Coplanar™ Flange	
Dielectric Kit w/CS Bolts (2 1/2" lg.) and 316 SS Washers	DEK-03C
Dielectric Kit w/316 SS Bolts (2 1/2" lg.) and 316 SS Washers	DEK-03F

To mount a 5 Valve Manifold with a ΔP to Static Adapter (ΔP to Transmitter Side) to a:	Part Number
Transmitter/Flow Computer with Traditional Flange	
Dielectric Kit w/CS Bolts (2 1/4" lg.) and 316 SS Washers	DEK-12C
Dielectric Kit w/316 SS Bolts (2 1/4" lg.) and 316 SS Washers	DEK-12F
Transmitter/Flow Computer with Rosemount Coplanar™ Flange	
Dielectric Kit w/CS Bolts (3 3/4" lg.) and 316 SS Washers	DEK-13C
Dielectric Kit w/316 SS Bolts (3 3/4" lg.) and 316 SS Washers	DEK-13F

Flange Seal Rings and Valve Seats

Components	Material	Part Number	Components	Material	Part Number
Flange Seal Ring for Stabilized Connectors and Manifolds	PTFE	S006.23.351.08	Valve Seats – Equalize and Vent Valves – 0.138" (3.5 mm) Bore Size	POM	S007.01.350.0801
	FKM	531044		PCTFE	S007.01.350.0803
Valve Seats – Isolate Valves (Block Valves) – 3/8" (9.5 mm) Bore Size	ETFE	S007.01.350.1105		PEEK	S007.01.350.0804
	POM	S007.01.350.1101			
	PEEK	S007.01.350.1104			

YOUR GLOBAL PARTNER

for Instrumentation and
Double Block & Bleed Valves



Visit us on:



ARMATURENFABRIK FRANZ SCHNEIDER GMBH + CO. KG
World Headquarters
Bahnhofplatz 12, 74226 Nordheim, Germany
Tel: +49 7133 101-0
www.as-schneider.com



ARMATURENFABRIK FRANZ SCHNEIDER SRL
Gradinari 32-38, 100404 Ploiesti
Romania
Tel: +40 244 384 963
www.as-schneider.ro



AS-SCHNEIDER ASIA-PACIFIC PTE. LTD.
970 Toa Payoh North, #02-12/14/15, Singapore 318992,
Singapore
Tel: +65 62 51 39 00
www.as-schneider.sg



AS-SCHNEIDER AMERICA, INC.
17449 Village Green Dr, Houston, TX 77040
United States of America
Tel: +1 281 760 1025
www.as-schneider.com



AS-SCHNEIDER MIDDLE EAST FZE
P.O. Box 18749, Dubai
United Arab Emirates
Tel: +971 4 880 85 75
www.as-schneider.ae



AS-SCHNEIDER INDIA PTE. LTD.
Industrial Plot No. 1, Okkilpalayam Road,
Malumichampatti, 641050 Coimbatore, India
Tel: +91 999 544 2201
www.as-schneider.com

