

INDUSTRIAL VALVES

PRODUCT OVERVIEW



AS-SCHNEIDER – AT

ENGINEERING KNOW-HOW

AS-Schneider with its headquarters in Germany is one of the World's Leading Manufacturers of Instrumentation and Double Block & Bleed Valves.

Based on 140 years of experience, AS-Schneider has maintained a culture of innovation by continuously expanding its design, production and technology capabilities.

AS-Schneider provides an unsurpassed level of reliability to customers in the Oil & Gas, Refining and Petrochemical, Chemical, Power, Pulp and Paper, Marine and various other Industries.



A GLANCE



At AS-Schneider, our employees are a valuable asset. Our staff is committed to continuously developing innovative designs, production and technology capabilities in order to provide the best solution to ensure customer satisfaction.

Apprenticeships and regular continuing education are our investment in the future. So an apprenticeship at AS-Schneider goes beyond the conventional.

We have a versatile and sustainable apprenticeship concept that lets our apprentices and interns learn quickly, take over independent responsibility, and link the theory they've learned with practical hands-on experience.



AS-Schneider's 210,000 square feet (approx. 20,000 m²)

MANUFACTURING FACILITIES IN GERMANY AND ROMANIA

are featuring large production areas that includes complete, partly highly-automated, machining facilities, certified welding departments and modern assemblies. These departments along with a large inventory of standard parts and stock valves allow AS-Schneider to have complete control of all aspects of the manufacturing process, even for the most demanding projects.

The most common raw materials we are handling are Brass, Carbon Steel, Alloy Steel, Stainless Steel, Duplex Stainless Steel and Nickel based Alloys like Alloy 400, C-276 and 625.

With a full staff of professional engineers, a technical sales team and perfectly skilled service technicians, AS-Schneider is more than a manufacturer.

WE ARE A PARTNER FOR PROVIDING SOLUTIONS TO THE DEMANDS OF OUR CUSTOMERS.



We have built a company that's a proven help to customers. We have built a worldwide reputation for superior quality and dependability with customers in every industry – Our customers give us this reputation and we are grateful for their recommendations.

From standard applications to the most sophisticated, AS-Schneider continues to provide solutions to manage



SEVERE-SERVICE PROCESSES AROUND THE WORLD.

Subsidiaries in Romania, Singapore, Dubai and Houston as well as experienced partners in more than 20 other countries are guaranteeing a global presence.

Our regional presence gives our customers not only short response times, but also competent, personal support in the implementation of individual projects.

The combination of our local market knowledge and our worldwide quality expectations allows us to support every customer requirement.



AS-SCHNEIDER USES INTERNATIONAL QUALITY STANDARDS

to assure that we conform to specified requirements throughout our total process.

These requirements include design, development, order processing, production, purchasing, quality control, installation and service.

Our own processes are based on the requirements of ISO 9001, PED, KTA 1401 and AD 2000 data sheet W 0 and HP 0.





OUR PRODUCTS ARE APPROVED ACCORDING TO:

- TR-TS (EAC) certificate for customs union (Russia, Belarus, Kazakhstan) – formerly GOST-R
- RTN (ROSTEKHNADZOR)
- ISO 15848-1
- TA-Luft
- CRN
- DVGW
- ISO 10497 and API 607

PROCESS CONDITIONS

such as pressure – up to 2,000 bar (29,000 psi) – and temperature – from -196°C (-321°F) to 700°C ($1,292^{\circ}\text{F}$) – or abrasive, viscous, toxic or flammable fluids, have their own characteristic problems and hazards.

AS-Schneider is prepared to handle these challenges.



VALVES AND MANIFOLDS FOR
CONVENTIONAL INSTALLATIONS

PAGE 8-9

VALVES AND MANIFOLDS FOR
CLOSED COUPLED INSTALLATIONS

PAGE 10-13



INSTRUMENTATION VALVES
AND ACCESSORIES

PAGE 14

DOUBLE BLOCK &
BLEED PIPING BALL VALVES

PAGE 15



Instrumentation Valves and Manifolds for Pressure, Flow and Level Applications

Conventional Installations using Impulse Lines to connect Pressure Instruments with the Pressure Taps.

Valves and Manifolds for General Applications

For Pressure and Differential Pressure Measurement Applications

- For all common instrument connections, either threaded or flanged interface
- Get all Mounting Bracket Kits and Accessories needed for a perfect installation
- Enjoy the low operation torque of the valves
- Use our long-term experience regarding absolute low leakage rates



VALVES AND MANIFOLDS FOR CONVENTIONAL INSTALLATIONS

Fully Assembled Enclosure Systems

Modular Design according to Customers' Specifications

- Fully assembled systems – including Manifolds, Valves, Heaters, Adapters, Brackets and Fittings
- Eliminates on-site assembly time, and last-minute compatibility problems
- Provides a weatherproof barrier for every type of installation
- Protects process instrumentation not only from the effects of sun, rain, frost, aggressive atmosphere or dirt but also from accidental damage or unauthorized access

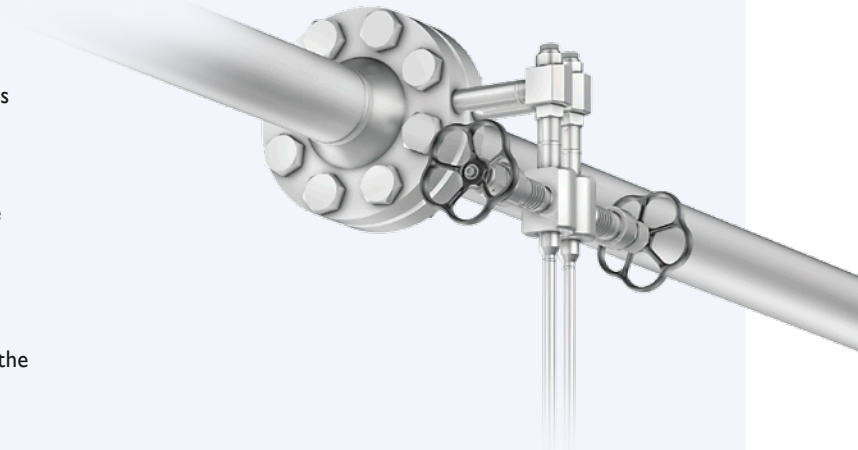

Valves and Manifolds for Power Plants

Primary Isolation Valves, Condensate Pots and Manifold-Combinations for Steam Flow Applications

- Get prefabricated assemblies designed for high temperature steam applications
- Reduced installation costs
- Optimizes measurement performance
- Reduced leak paths

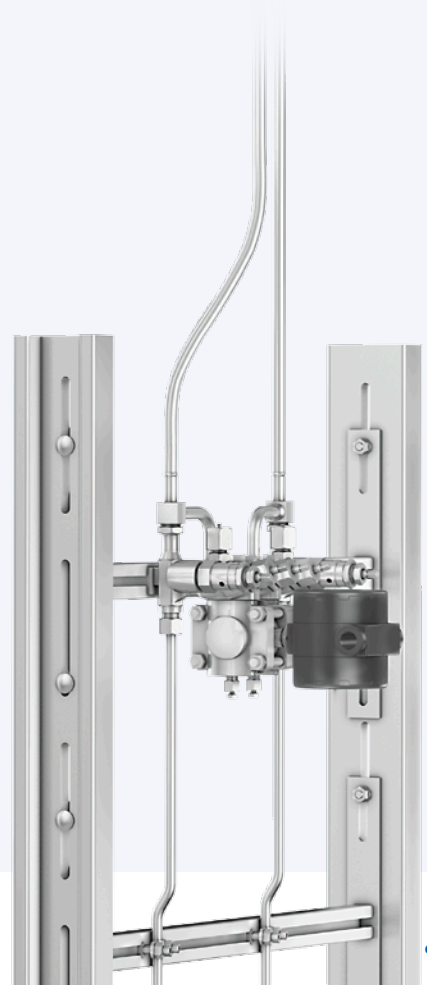
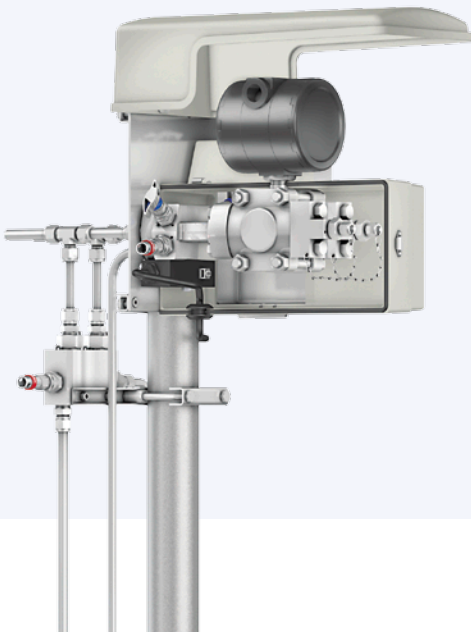
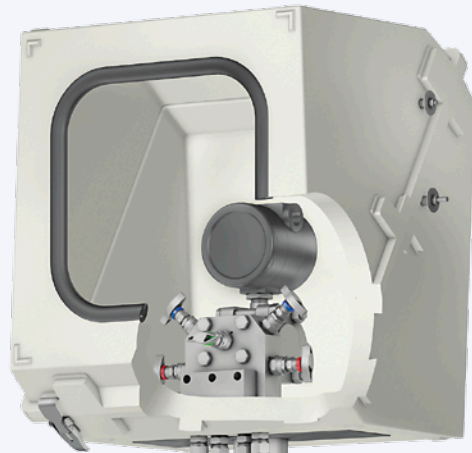



Instrumentation Valves and Manifolds for Pressure, Flow and Level Applications

Close Coupled Installation Benefits

- Optimizes performance by eliminating impulse lines
- Reduced leak paths means increased safety and improved performance
- Reduced installation costs
- Reduced costs of ownership
- Reduced maintenance and downtime
- Ensures accurate and consistent measurements
- Reduces the risk of fugitive emissions

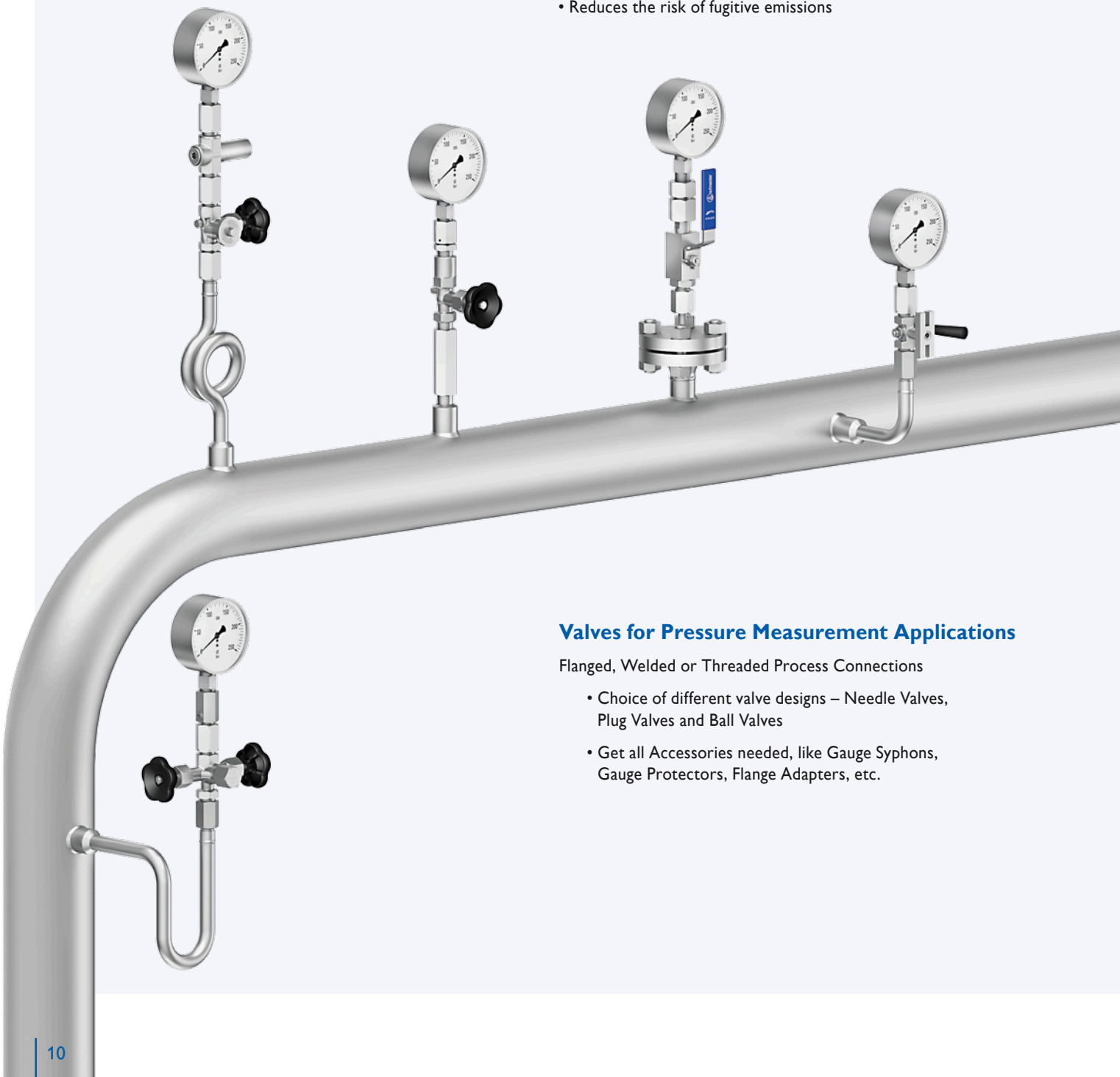

Valves for Pressure Measurement Applications

Flanged, Welded or Threaded Process Connections

- Choice of different valve designs – Needle Valves, Plug Valves and Ball Valves
- Get all Accessories needed, like Gauge Syphons, Gauge Protectors, Flange Adapters, etc.

VALVES AND MANIFOLDS FOR CLOSE COUPLED INSTALLATIONS

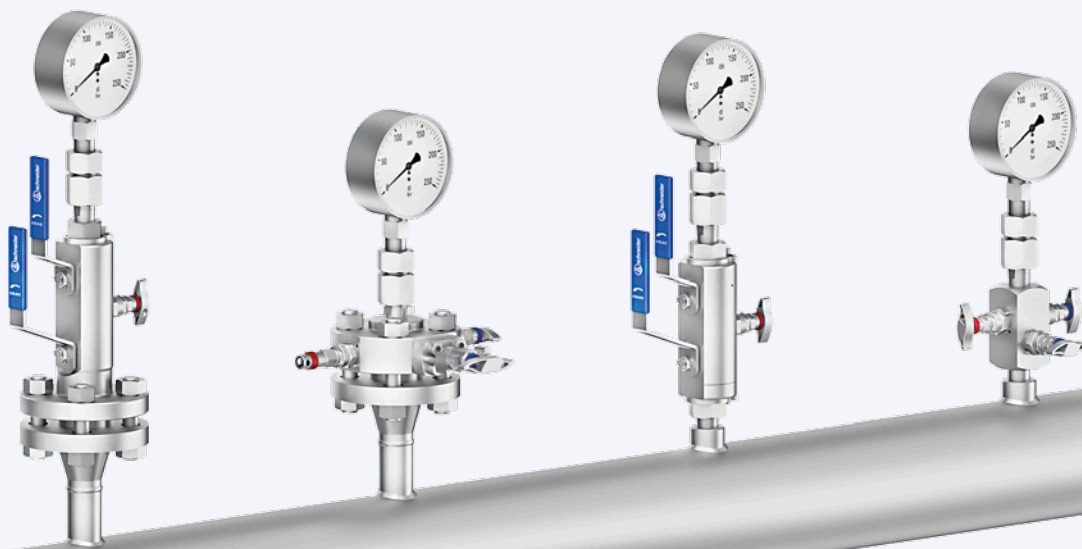

Double Block & Bleed Valve Applications

Root Valves, Monoflanges and VariAS-Blocks

- Flanged, threaded or welded process connections
- Flanged or threaded instrument connections
- Primary Isolation Valves as Ball Valve, OS&Y Bolted Bonnet Valve or Needle Valve
- Injection and sampling applications available
- Weight and space saving assembly
- Compact and efficient arrangement





Schneider DirectMount Systems

Compact Pressure and Flow Hook-ups for Natural Gas Applications

- Get all components for your assembly like Stabilized Connectors, Dielectric Isolation Kits, Manifolds and Adapters
- Soft Seated Valves and Manifolds – fully roddable due to Straight-Through Valve Seat Design (Bore Size 3/8")
- Innovative design of Valve Head Units gives long service life and a smooth, low-torque operation
- Reduces / eliminates gauge line error and/or square root error
- Reduces freezing issues

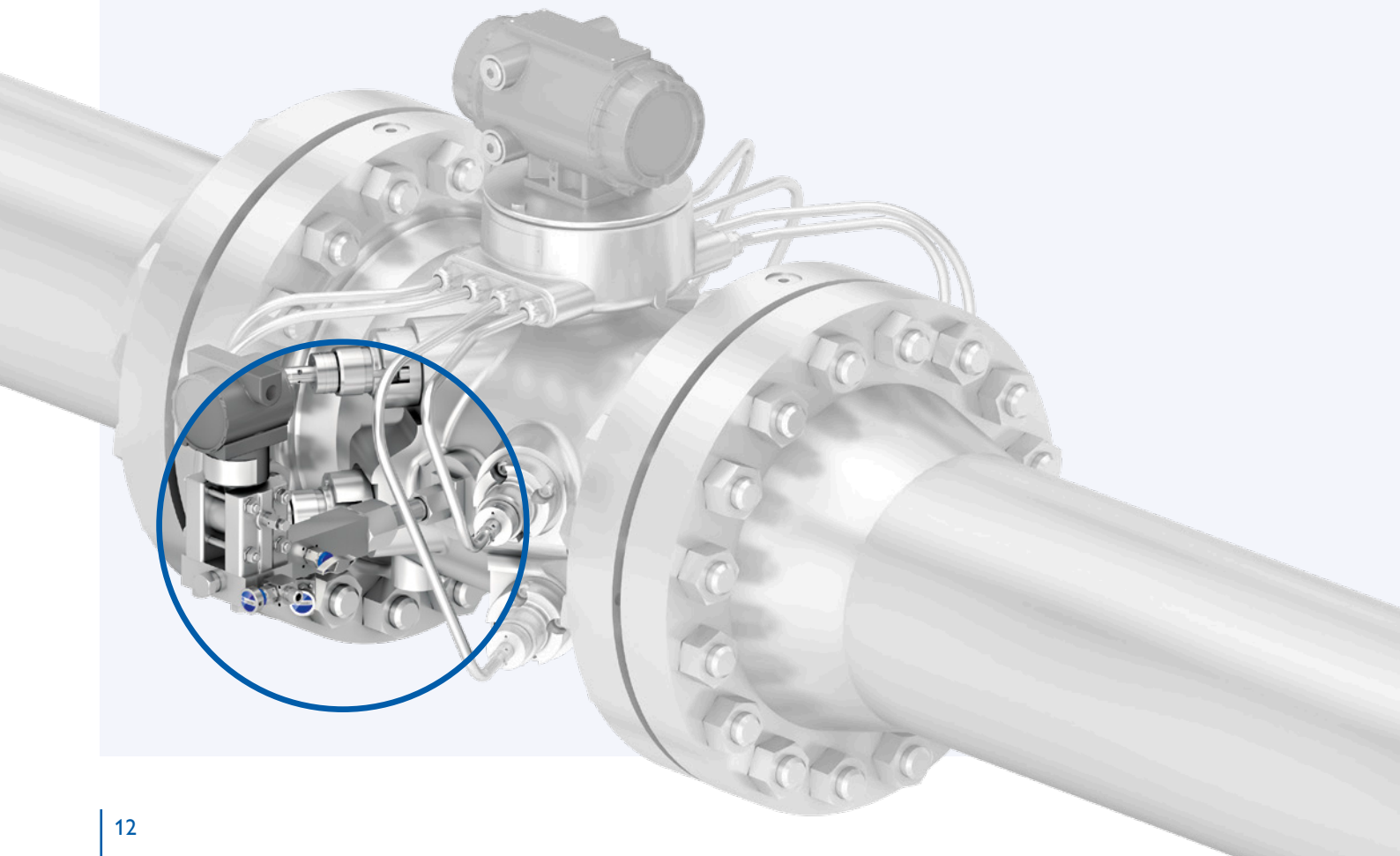
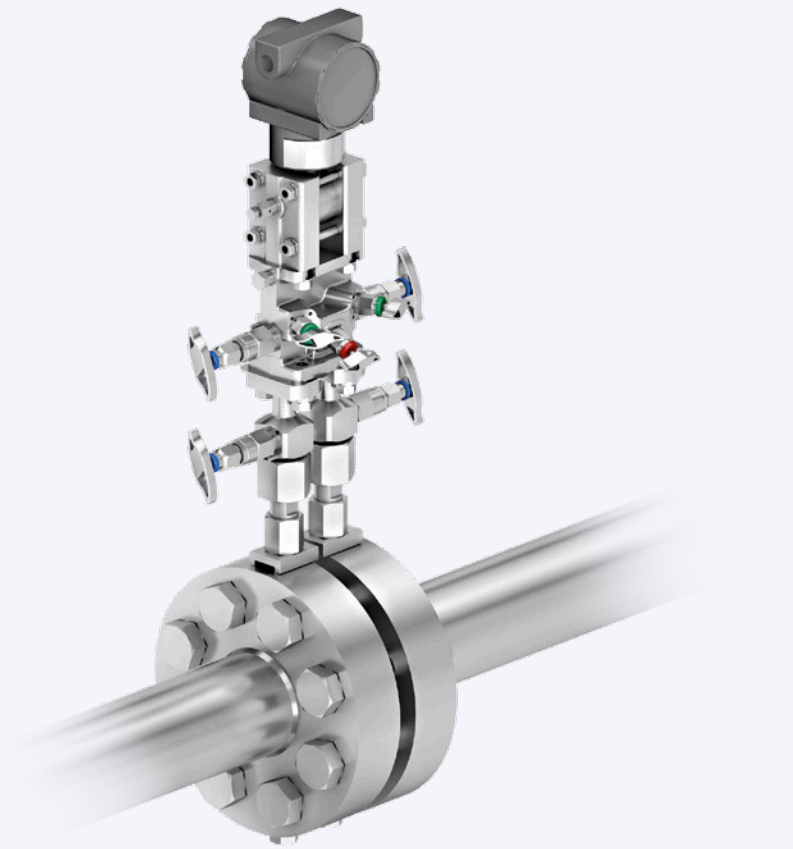

VALVES AND MANIFOLDS FOR CLOSE COUPLED INSTALLATIONS

D Series Hook-ups

Close Coupled Instrument Installation System combining Ball Valves, Globe Valves, Manifolds and Flush Rings for Pressure, Flow and Level Measurement Applications

- Prefabricated assemblies minimizes site work
- Reduced installation and testing costs
- Available in a huge variety of options
- Elimination of threaded connections and impulse piping
- Fully-welded Ball Valves and generally Reduced Potential Leak Points are Reducing Fugitive
- Most of the Valves and Manifolds are soft seated and therefore fully roddable
- Eliminates condensation and plugging of long impulse lines improving system reliability

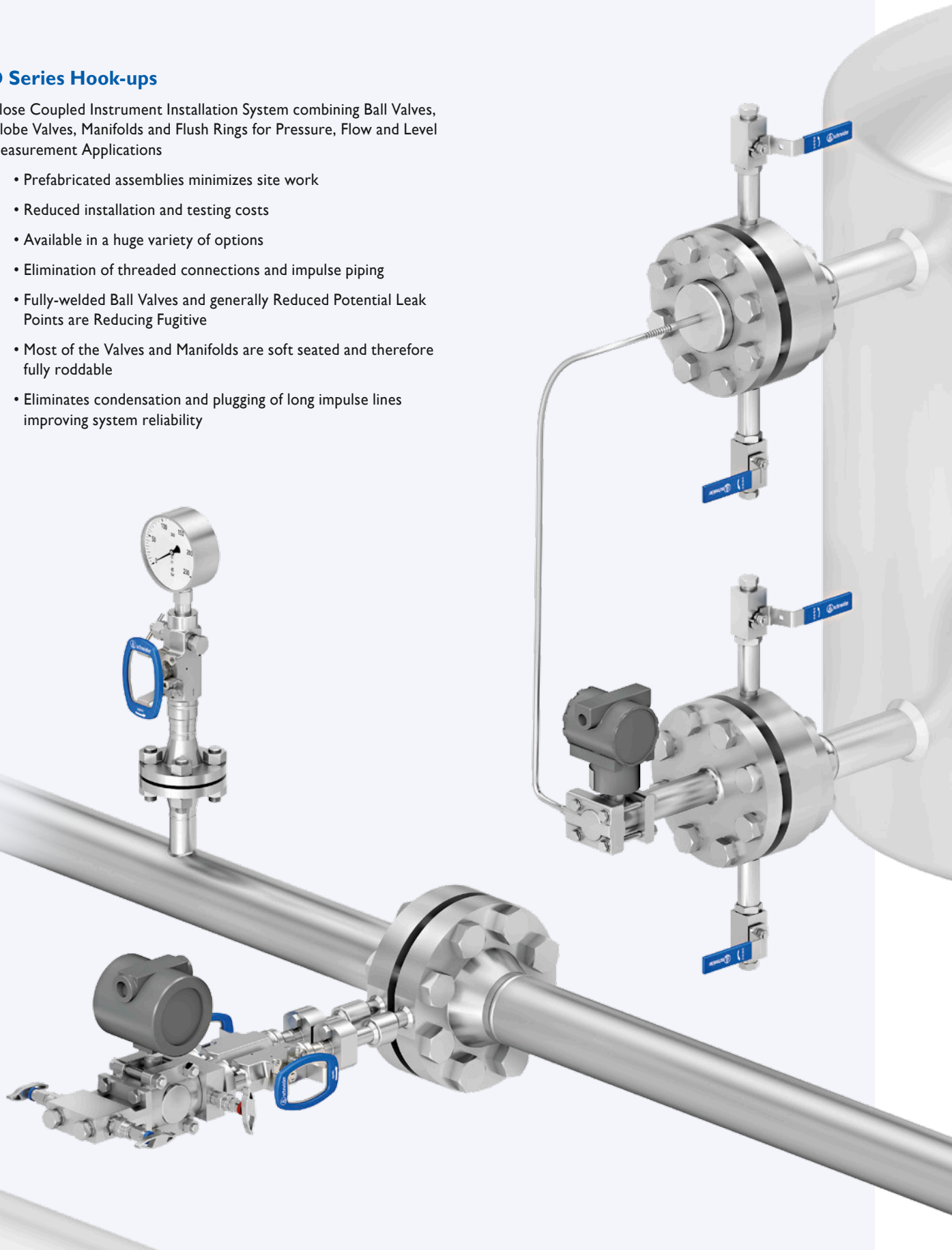

INSTRUMENTATION VALVES AND ACCESSORIES



NEEDLE TYPE GLOBE VALVES



BALL VALVES

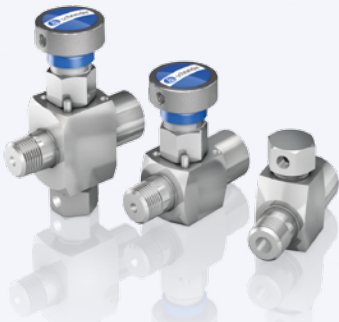

MINI VALVES AND RUPTURE DISC HOLDERS

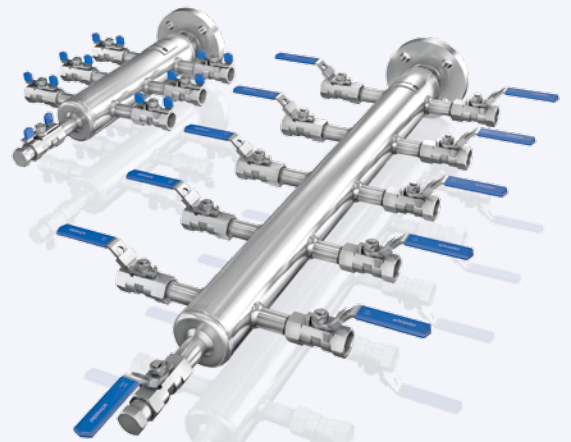

AIR HEADERS



VALVES FOR LARGE BORE DIESEL ENGINES



MOUNTING ACCESSORIES

DOUBLE BLOCK & BLEED PIPING BALL VALVES

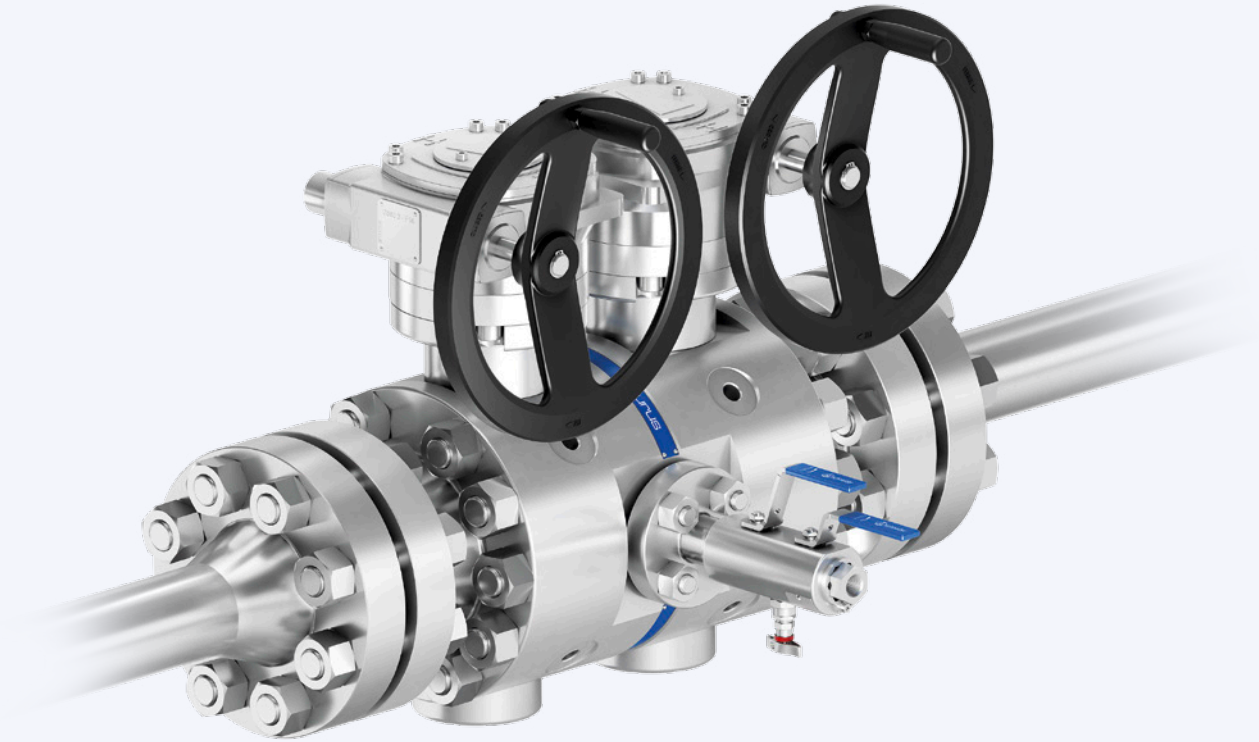

Double Block & Bleed Piping Ball Valves – Taurus Series

Full Bore or Reduced Bore Floating Design and Trunnion Design Ball Valves

- Both, 2 Piece Design and 3 Piece Design, are available
- Lever operated, gear operated or actuated
- Significant weight, space and cost saving
- Reduced leak paths reducing fugitive emissions

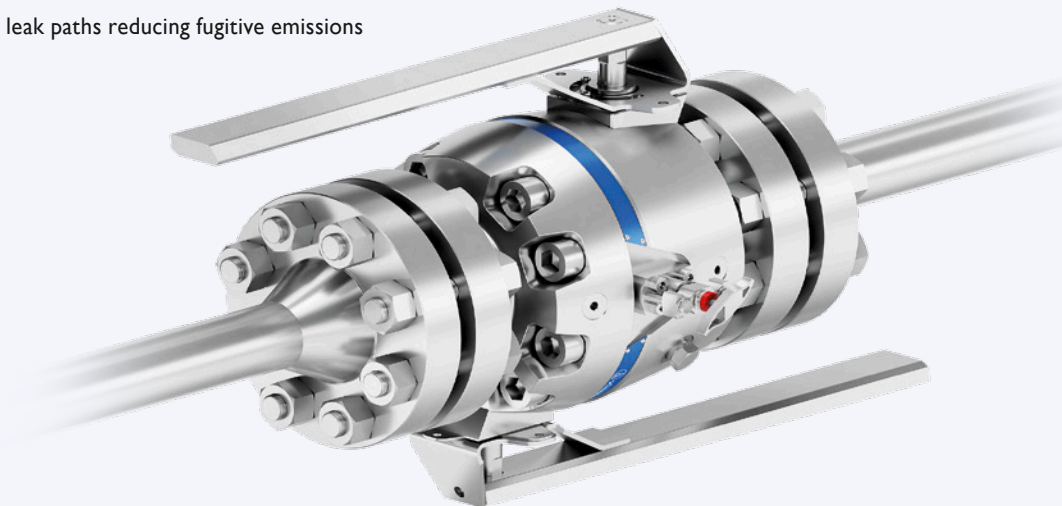

YOUR GLOBAL PARTNER

for Instrumentation and
Double Block & Bleed Valves



Visit us on:



ARMATURENFABRIK FRANZ SCHNEIDER GMBH + CO. KG

World Headquarters
Bahnhofplatz 12, 74226 Nordheim, Germany

Tel: +49 7133 101-0
www.as-schneider.com



ARMATURENFABRIK FRANZ SCHNEIDER SRL

Gradinari 32-38, 100404 Ploiesti
Romania

Tel: +40 244 384 963
www.as-schneider.ro



AS-SCHNEIDER ASIA-PACIFIC PTE. LTD.

970 Toa Payoh North, #02-12/14/15, Singapore 318992,
Singapore

Tel: +65 62 51 39 00
www.as-schneider.sg



AS-SCHNEIDER AMERICA, INC.

17471 Village Green Dr, Houston, TX 77040
United States of America

Tel: +1 281 760 1025
www.as-schneider.com



AS-SCHNEIDER MIDDLE EAST FZE

P.O. Box 18749, Dubai
United Arab Emirates

Tel: +971 4 880 85 75
www.as-schneider.ae



AS-7701-EN | April 2018