

# Thermowell for weld-in or with flange (solid-machined)

## Design per DIN 43772 form 4, 4F

### Model TW55

WIKA data sheet TW 95.55

#### Applications

- Chemical industry, process technology, equipment manufacturing
- For high process loads

#### Special features

- Designs per DIN 43772
- Design TW55-6: Form 4 to weld-in  
Design TW55-7: Form 4F with flange
- For highly corrosion-resistant coatings (design TW55-7)



**Fig. left: Weld-in thermowell, design TW55-6**

**Fig. right: Thermowell with flange, design TW55-7**

#### Description

Each thermowell is an important component of any temperature measuring location. It is used to separate the process from the surrounding area, thus protecting the environment and operating personnel and keeps aggressive media, high pressures and flow rates from the temperature probe itself and thereby enables the thermometer to be exchanged during operation.

Based on the almost limitless application possibilities, there are a large number of variants, such as thermowell designs or materials. The type of process connection and the basic method of manufacture are important design differentiation criteria. A basic differentiation can be made between threaded and weld-in thermowells, and those with flange connections.

Furthermore, one can differentiate between fabricated and solid-machined thermowells. Fabricated thermowells are constructed from a tube, that is closed at the tip by a welded solid tip. Solid-machined thermowells are manufactured from solid bar stock.

The TW55 series of solid-machined thermowells for weld-in or with flange connection are suitable for use with numerous electrical and mechanical thermometers from WIKA.

Due to their design to DIN 43772, these thermowells for high process loads are suitable for use in the chemical industry, process technology and equipment manufacturing.

## Specifications

Models TW55-6 and TW55-7	
<b>Designs per DIN 43772</b>	<ul style="list-style-type: none"> <li>■ Design TW55-6: Form 4 to weld-in</li> <li>■ Design TW55-7: Form 4F with flange, for highly corrosion-resistant coatings</li> </ul>
<b>Thermowell materials</b>	<ul style="list-style-type: none"> <li>■ Stainless steel 1.4571</li> <li>■ Stainless steel 316/316L</li> <li>■ Steel P250GH (former designation: 1.0460, C22.8)</li> <li>■ Steel 1.5415</li> <li>■ Steel 1.7380</li> </ul>
<b>Process connection <sup>1)</sup></b>	
Thermowell outer diameter (bar diameter)	<ul style="list-style-type: none"> <li>■ Ø 18 mm [0.71 in]</li> <li>■ Ø 24 mm [0.94 in]</li> <li>■ Ø 26 mm [1.02 in]</li> <li>■ Ø 32 mm [1.26 in]</li> </ul>
Flanges to valid national or international standards	<ul style="list-style-type: none"> <li>■ EN 1092-1</li> <li>■ DIN 2527</li> <li>■ ASME</li> </ul>
<b>Connection to thermometer</b>	<ul style="list-style-type: none"> <li>■ M14 x 1.5 female thread</li> <li>■ M18 x 1.5 female thread</li> <li>■ G ½ female thread</li> <li>■ G ¾ female thread</li> </ul>
<b>Bore size</b>	<ul style="list-style-type: none"> <li>■ Ø 3.5 mm [0.14 in]</li> <li>■ Ø 7 mm [0.28 in]</li> <li>■ Ø 9 mm [0.35 in]</li> <li>■ Ø 11 mm [0.43 in]</li> </ul>
<b>Insertion length U<sub>1</sub>, cone length U and overall length L</b>	For design combinations, see table page 4
<b>Coating</b>	
PFA	<ul style="list-style-type: none"> <li>■ Layer thickness min. 0.4 mm</li> <li>■ Layer thickness min. 0.6 mm</li> </ul>
ECTFE (Halar <sup>®</sup> )	Layer thickness min. 0.6 mm
<b>Max. process temperature, process pressure</b>	Depending on <ul style="list-style-type: none"> <li>■ Load diagram DIN 43772</li> <li>■ Thermowell design               <ul style="list-style-type: none"> <li>- Dimensions</li> <li>- Material</li> <li>- Flange pressure rating</li> <li>- Coating</li> </ul> </li> <li>■ Process conditions               <ul style="list-style-type: none"> <li>- Flow rate</li> <li>- Medium density</li> </ul> </li> </ul>
<b>Wake frequency calculation</b>	For critical applications, is recommended in accordance with Dittrich/Klotter or ASME PTC 19.3 TW-2016 as a WIKA engineering service  For further information, see Technical information IN 00.15 "Wake frequency calculation".

1) Other process connections on request

Halar<sup>®</sup> ECTFE is a registered trademark of the company Solvay Solexis.

## Dimensions in mm [in]

### Design TW55-7

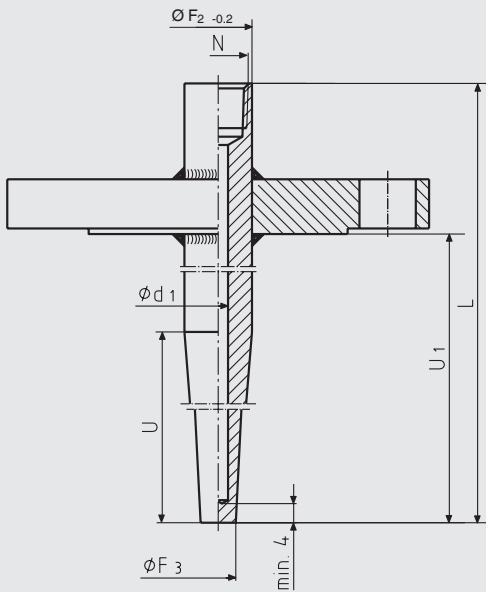

### Design TW55-6

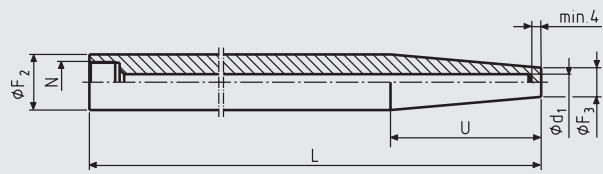

#### Legend:

- L Overall length
- U<sub>1</sub> Insertion length
- U Cone length
- N Connection to thermometer
- Ø d<sub>1</sub> Bore size
- Ø F<sub>2</sub> Thermowell outer diameter (bar diameter)
- Ø F<sub>3</sub> Tip diameter
- M Neck tube length

3088944.02

### Design TW55-6 with neck tube

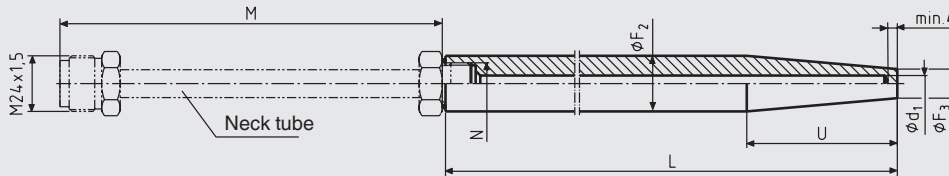

### Standard lengths design TW55-7

Dimensions in mm [in]			Weight in kg [lbs]	
L	U	U <sub>1</sub>	DN 25, PN 40	DN 50, PN 40
200 [7.87]	65 [2.56]	130 [5.12]	1.9 [4.19]	3.8 [8.38]
260 [10.24]	125 [4.29]	190 [7.48]	2.1 [4.63]	4.0 [8.82]
410 <sup>1)</sup> [16.14]	275 [10.83]	340 [13.39]	2.3 [5.07]	4.2 [9.26]

### Standard lengths design TW55-6

Dimensions in mm [in]		Weight in kg [lbs]
L	U	
110 [4.33]	65 [2.56]	0.24 [0.53]
110 [4.33]	73 [2.87]	0.23 [0.51]
140 [5.51]	65 [2.56]	0.34 [0.75]
170 [6.69]	133 [5.24]	0.34 [0.75]
200 [7.87]	65 [2.56]	0.54 [1.19]
200 [7.87]	125 [4.92]	0.45 [0.99]
260 [10.24]	125 [4.92]	0.65 [1.43]
410 <sup>2)</sup> [16.14]	275 [10.83]	0.92 [2.03]

### Standard connection thread

Dimensions in mm [in]					
N	Ø d <sub>1</sub>	Ø F <sub>2</sub>	Ø F <sub>3</sub>	H <sub>1</sub>	H <sub>2</sub>
M14 x 1.5	3.5 [0.14]	18 [0.71]	9 [0.35]	16 [0.63]	13 [0.51]
M18 x 1.5	7 [0.28]	24 [0.94]	12.5 [0.49]	16 [0.63]	13 [0.51]
G ½	7 [0.28]	26 [1.02]	12.5 [0.49]	19 [0.75]	15 [0.59]
G ½	9 [0.35]	26 [1.02]	15 [0.59]	19 [0.75]	15 [0.59]
G ¾	11 [0.43]	32 [1.26]	17 [0.67]	22 [0.87]	17 [0.67]

1) Not with bore size Ø d<sub>1</sub> = 3.5 mm [0.14 in]

2) Standard of the neck tube length M = 165 mm [6.5 in]

## Suitable stem lengths

### ■ Dial thermometer

Connection design	Stem length $l_1$	
	Without neck tube	With neck tube
S, 4 or 5	$l_1 = L - 10 \text{ mm [0.4 in]}$	-
2	$l_1 = L - 30 \text{ mm [1.2 in]}$	-
3	-	$l_1 = L + M - 10 \text{ mm [0.4 in]}^{1)}$

### ■ Machine glass thermometer

Connection design	Stem length $l_1$	
	Without neck tube	With neck tube
E	$l_1 = L - 10 \text{ mm [0.4 in]}$	-
3	-	$l_1 = L + M - 10 \text{ mm [0.4 in]}^{1)}$

1) Standard of the neck tube length  $M = 165 \text{ mm [6.5 in]}$

## Design combinations insertion length $U_1$ , cone length $U$ and overall length $L$ in mm [in]

Thermowell	Insertion length	Cone length	Overall length
Model	$U_1$	$U$	$L$
<b>TW55-6</b> (Form 4 to weld-in)	-	<ul style="list-style-type: none"> <li>■ 65 [2.56]</li> <li>■ 73 [2.87]</li> <li>■ 125 [4.92]</li> <li>■ 133 [5.24]</li> <li>■ 275 [10.83]</li> </ul>	<ul style="list-style-type: none"> <li>■ 110 [4.33]</li> <li>■ 140 [5.51]</li> <li>■ 170 [6.69]</li> <li>■ 200 [7.87]</li> <li>■ 260 [10.24]</li> <li>■ 410 [16.14]</li> </ul>
<b>TW55-7</b> (form 4F with flange)	<ul style="list-style-type: none"> <li>■ 130 [5.12]</li> <li>■ 190 [7.48]</li> <li>■ 340 [13.39]</li> </ul>	<ul style="list-style-type: none"> <li>■ 65 [2.56]</li> <li>■ 125 [4.92]</li> <li>■ 275 [10.83]</li> </ul>	<ul style="list-style-type: none"> <li>■ 200 [7.87]</li> <li>■ 260 [10.24]</li> <li>■ 410 [16.14]</li> </ul>

## Sealing face roughness

Flange standard		AARH in $\mu\text{inch}$	Ra in $\mu\text{m}$	Rz in $\mu\text{m}$
<b>ASME B16.5</b>	Stock finish	125 ... 250	3.2 ... 6.3	-
	Smooth finish	< 125	< 3.2	-
	RTJ	< 63	< 1.6	-
	Tongue/groove	< 125	< 3.2	-
<b>EN 1092-1</b>	Form B1	-	3.2 ... 12.5	12.5 ... 50
	Form B2	-	0.8 ... 3.2	3.2 ... 12.5
<b>DIN 2527</b>	Form C	-	-	40 ... 160
	Form E	-	-	< 16

# Pressure-temperature diagram <sup>1)</sup>

Thermowell model TW55 made of stainless steel 1.4571

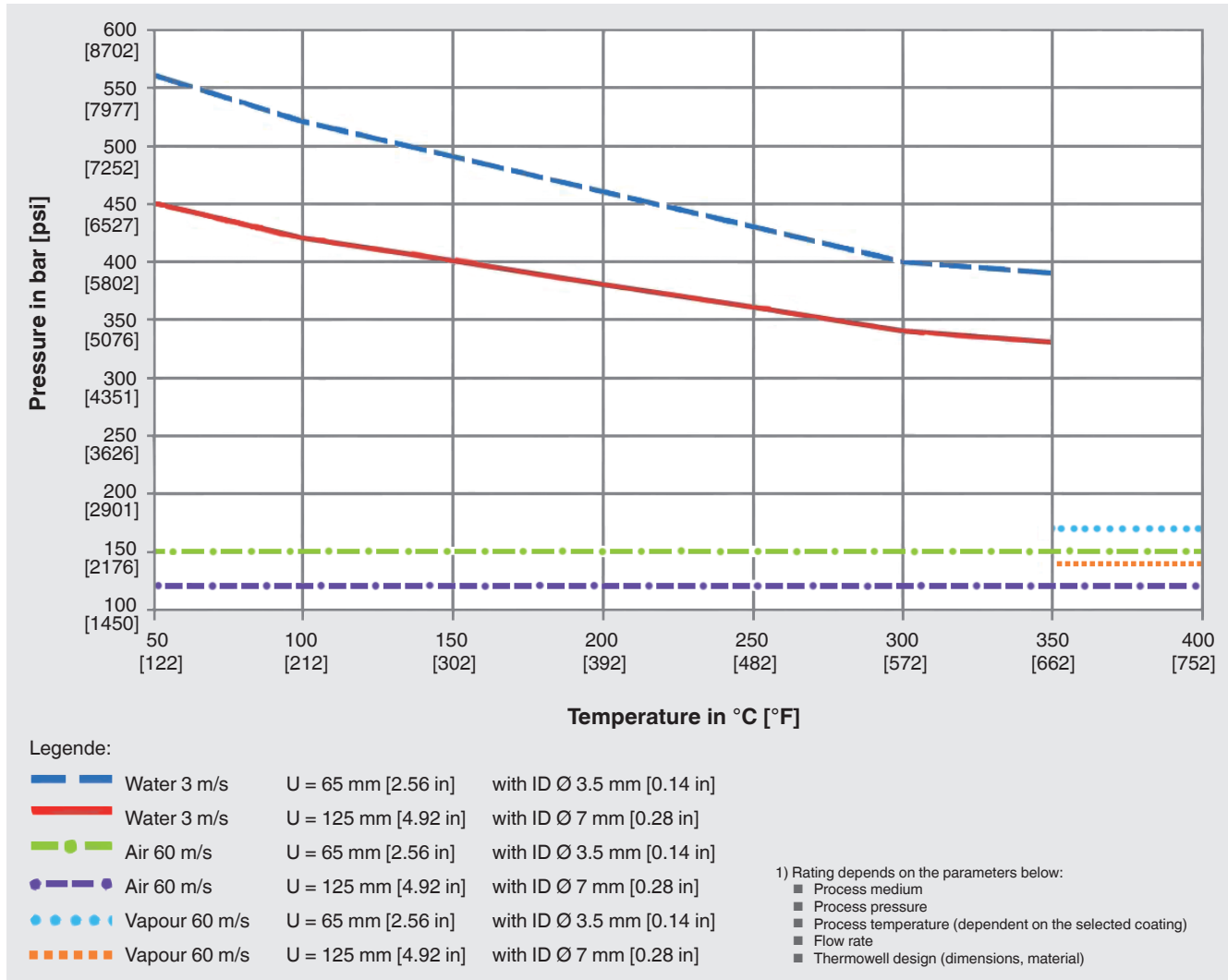

## Certificates (option)

- 2.2 test report
- 3.1 inspection certificate

## Ordering information

Model / Thermowell form / Thermowell material / Bar diameter  $\varnothing F_2$  / Connection to the thermometer /  
 Bore size  $\varnothing d_1$  / Nominal width DN / Pressure rating PN / Sealing face / Tip diameter  $\varnothing F_3$  / Insertion length  $U_1$  /  
 Cone length U / Overall length L / Coating / Assembly with thermometer / Certificates / Options

© 12/2007 WIKA Alexander Wiegand SE & Co. KG, all rights reserved.  
 The specifications given in this document represent the state of engineering at the time of publishing.  
 We reserve the right to make modifications to the specifications and materials.



**ICS Schneider Messtechnik GmbH**  
 Briesestr. 59  
 D-16562 Hohen Neuendorf / OT Bergfelde  
 Tel.: +49 3303 5040-66  
 Fax: +49 3303 5040-68  
 E-Mail: info@ics-schneider.de



**WIKAL Alexander Wiegand SE & Co. KG**  
 Alexander-Wiegand-Straße 30  
 63911 Klingenberg/Germany  
 Tel. +49 9372 132-0  
 Fax +49 9372 132-406  
 info@wika.de  
 www.wika.de