

Flow nozzle for in-pipe installation, model FLC-FN-PIP

Flow nozzle for flange assembly, model FLC-FN-FLN

Venturi nozzle, model FLC-FN-VN

WIKA data sheet FL 10.03

Applications

- Power generation
- Oil production and refining
- Water treatment and distribution
- Gas processing and transmission
- Chemical and petrochemical industries

Special features

- Suitable for liquid, gas and steam flow measurement
- Optimum solution for measuring the flow of steam
- Accuracy $\leq \pm 0.1$ % of actual flow rate
- Repeatability of measurement 0.1 %
- Lowest pressure loss in the family of primary flow elements

Description

Wide variety of applications

The design of the flow nozzle is based on Bernoulli's equation and consists of a convergent section with a rounded profile and a cylindrical throat. Due to its rigidity the flow nozzle is dimensionally more stable at higher temperature and flow rate than an orifice.

The flow nozzle is generally used for measuring the flow of steam as well as non-viscous, erosive and high-velocity media.

They can be used in a wide variety of applications that include steam, air, water, vapour, gas, chemical substances and high temperatures. For applications with erosive media a hardened internal surface is available.



Flow nozzle for in-pipe installation, model FLC-FN-PIP



Flow nozzle for flange assembly, model FLC-FN-FLN



Venturi nozzle, model FLC-FN-VN

High accuracy

The design and manufacture of the flow nozzles complies with the requirements of ISO 5167.

Thus an accuracy of ± 1.0 % is ensured. By means of a calibration a higher accuracy of down to ± 0.25 % can be achieved.

For acceptance tests of power plants, flow nozzles to ASME PTC-6 are also available.

General specifications

Design

The design is calculated in accordance with the following standards

- ISO 5167-3
- ASME MFC3

Nominal size and pipe schedule

All nominal sizes are available in accordance with relevant standards. The pipe schedule must be specified by the customer.

Standards cover diameters from 2 ... 24" (60 ... 630 mm), larger diameters are available on request.

Nominal pressure rating

Available in accordance with all relevant standards.

Materials

A wide range of materials is available.

For applications with erosive media a hardened internal surface is available as an option.

Mounting options

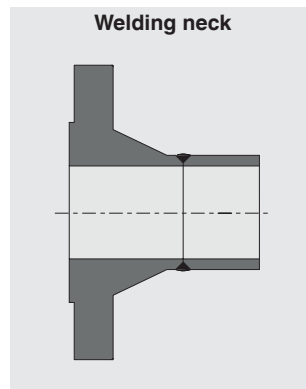
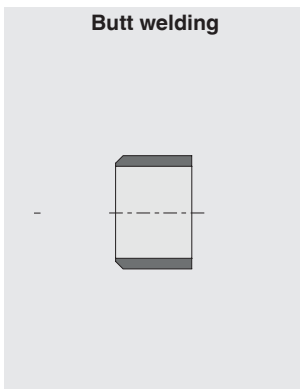

Sealing faces for flanged versions

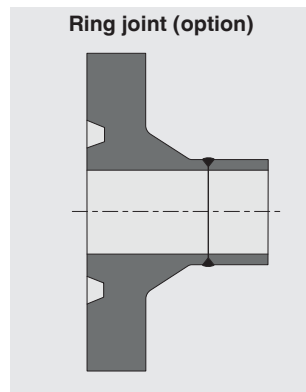
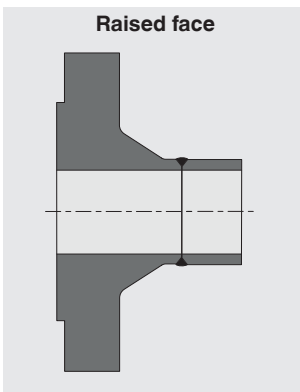

Pressure tappings

The best solution depends on the application and will be created individually. The number of pressure taps must be specified by the customer.

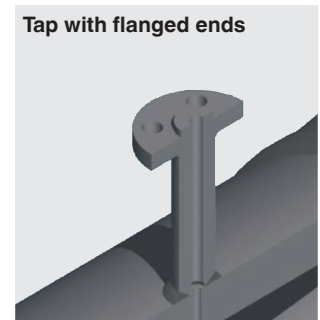
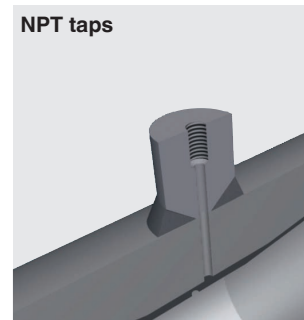

Specifications, model FLC-FN-PIP

Description

The long-radius nozzle to ASME has a curved inlet shaped like the quadrant of an ellipse. To obtain good measurement results, the flow nozzle should be well centred in the pipe.

Nominal size

50 ... 630 mm

Beta ratio

0.2 ... 0.8

Reynolds number

$10^4 \dots 10^7$

Accuracy

$\leq \pm 1$ % of full scale flow rate

By means of a calibration a higher accuracy of down to ± 0.25 % can be achieved.

Pressure tapings

Radius tap

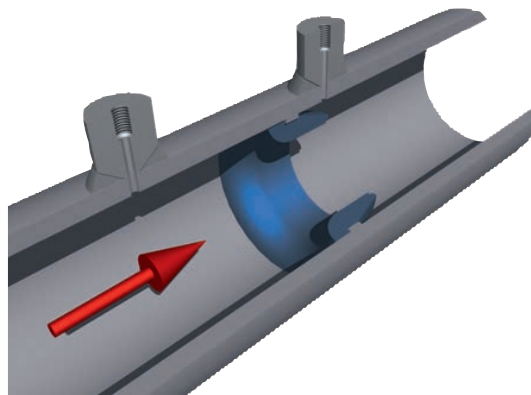

Flow nozzle for in-pipe installation, model FLC-FN-PIP

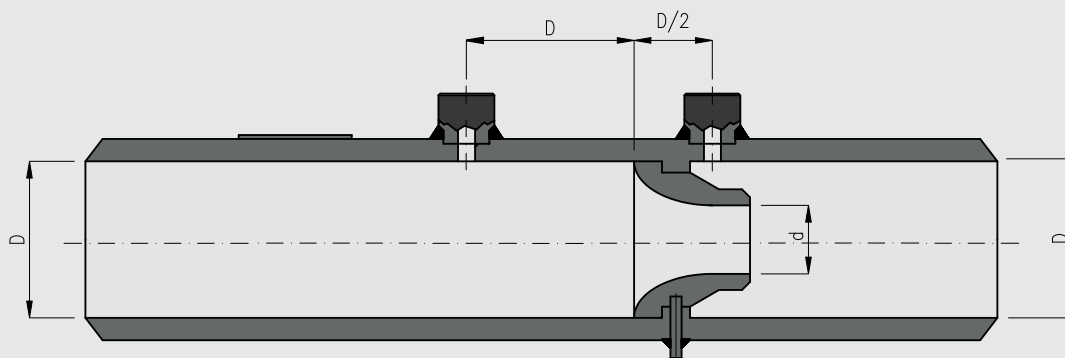

Specifications, model FLC-FN-FLN

Description

The flow nozzle to ISA 1932 (model FLC-FN-FLN) has a smooth central inlet leading to the throat section. The length of the flow nozzle depends on the beta ratio. The lower the beta ratio is, the shorter is also the length of the nozzle.

The model FLC-FN-FLN flow nozzle is usually clamped between flanges.

Nominal size

50 ... 500 mm

Beta ratio

0.3 ... 0.8

Reynolds number

$10^4 \dots 10^7$

Accuracy

$\leq \pm 1$ % of full scale flow rate

By means of a calibration a higher accuracy of down to ± 0.25 % can be achieved.

Pressure tapings

Corner taps



Flow nozzle for flange assembly, model FLC-FN-FLN

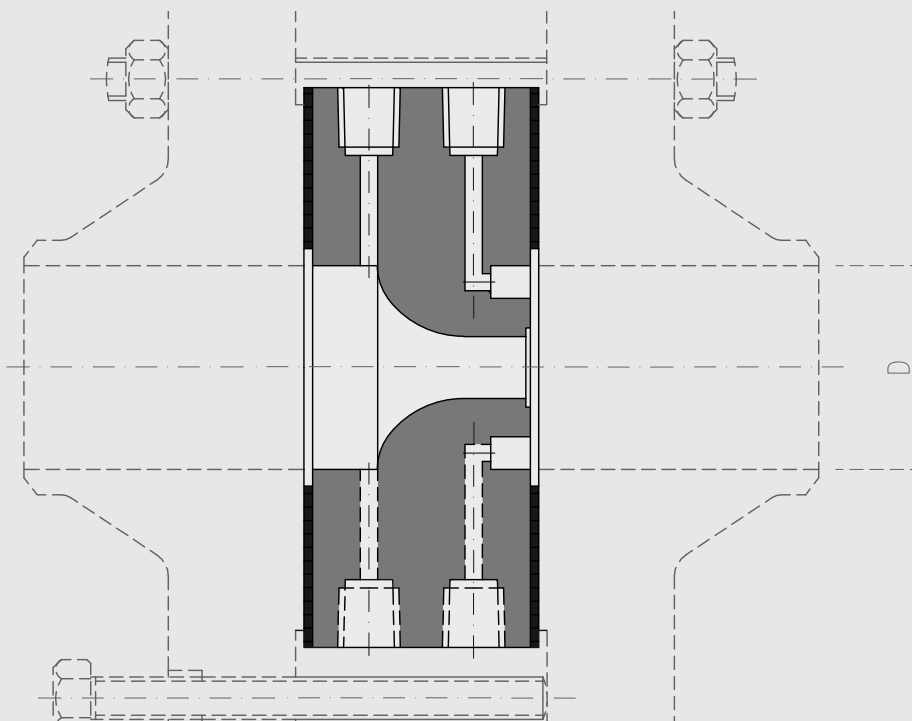

Specifications, model FLC-FN-VN

Description

The profile of the Venturi nozzle is axisymmetric and consists of a convergent inlet section with a rounded profile, a cylindrical throat section and a diffuser. The inlet has the same geometry as model FLC-FN-FLN (flow nozzle to ISA 1932).

Nominal size

65 ... 500 mm

Beta ratio

0.316 ... 0.775

Reynolds number

$1.5 \times 10^5 \dots 2 \times 10^6$

Accuracy

$\leq \pm 2 \%$ of full scale flow rate

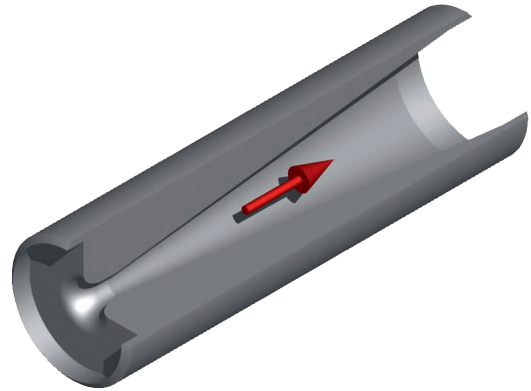

Venturi nozzle, model FLC-FN-VN

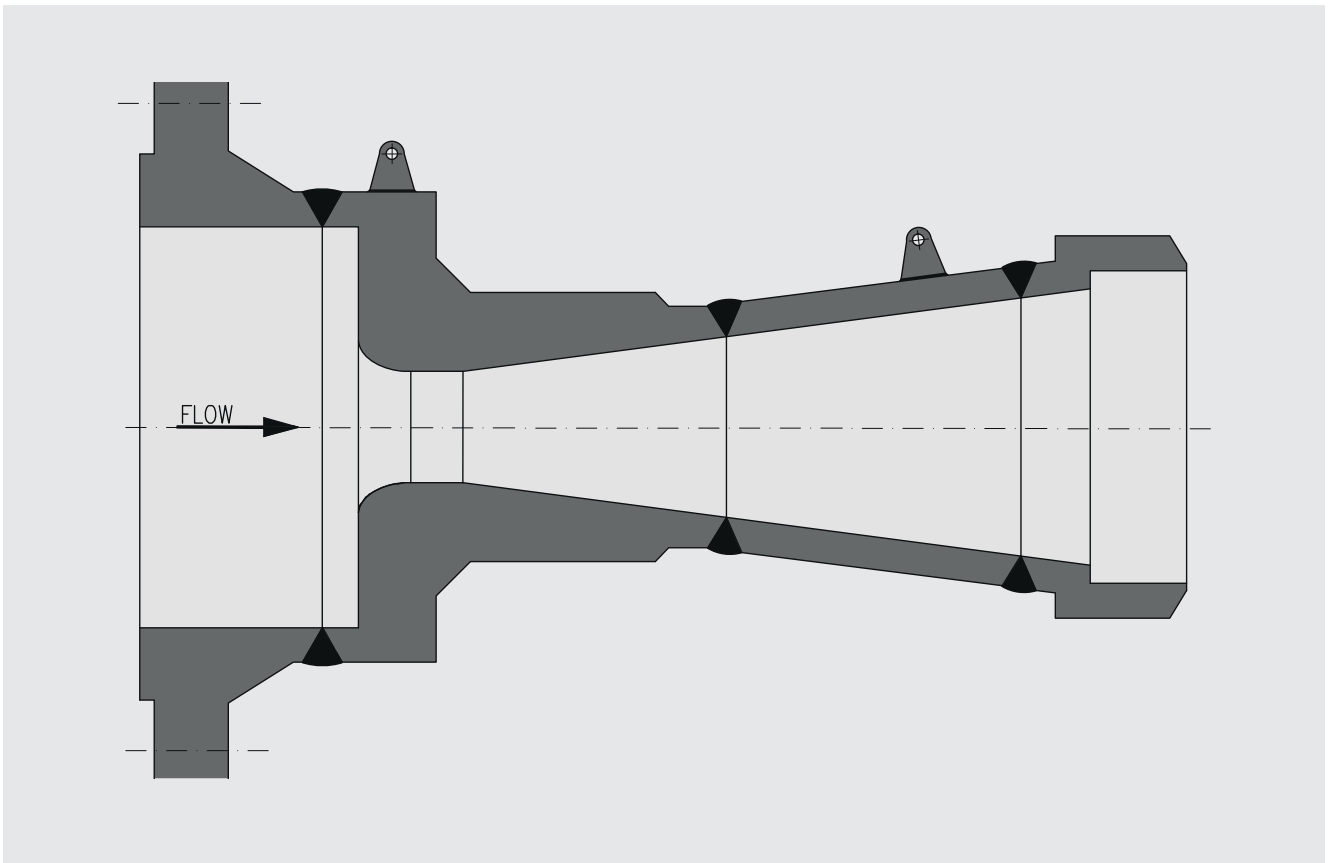

The design may change according to the nominal dimension and the process conditions.

Ordering information

Flow nozzle, model FLC-FN-PIP

Nominal size / Nominal pressure rating / Sealing face / Mounting option / Pressure tapping / Material

Flow nozzle, model FLC-FN-FLN

Nominal size / Pipe schedule / Nominal pressure rating / Sealing face / Mounting option / Pressure tapping / Material

Venturi nozzle, model FLC-FN-VN

Nominal size / Pipe schedule / Nominal pressure rating / Sealing face / Material

© 08/2013 WIKA Alexander Wiegand SE & Co. KG, all rights reserved.
The specifications given in this document represent the state of engineering at the time of publishing.
We reserve the right to make modifications to the specifications and materials.



ICS Schneider Messtechnik GmbH
Briesestrasse 59
D-16562 Hohen Neuendorf / OT Bergfelde
Tel.: +49 3303 5040-66
Fax: +49 3303 5040-68
E-Mail: info@ics-schneider.de



WIKAL Alexander Wiegand SE & Co. KG
Alexander-Wiegand-Straße 30
63911 Klingenberg/Germany
Tel. +49 9372 132-0
Fax +49 9372 132-406
info@wika.de
www.wika.de